

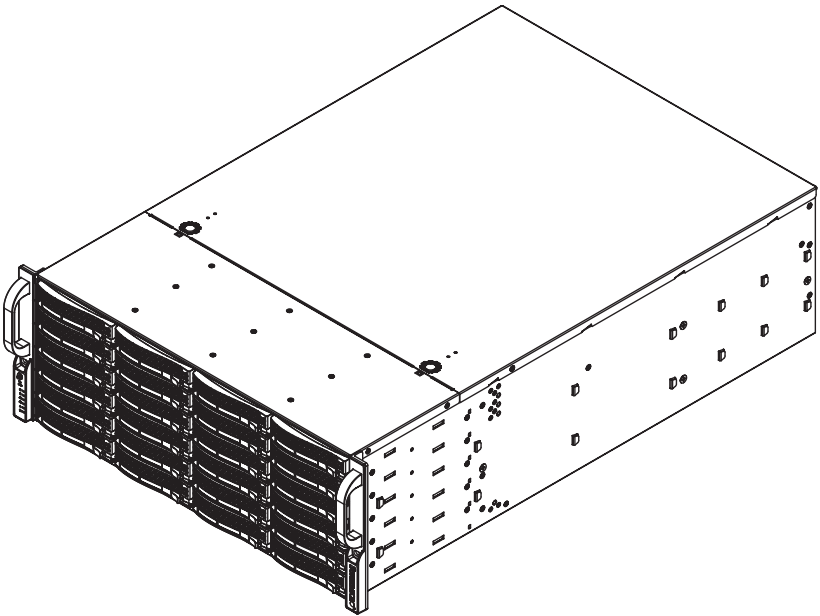

SC847 JBOD STORAGE ENCLOSURE SERIES



CSE-847E1C-R1K23JBOD CSE-847E2C-R1K23JBOD

USER'S MANUAL

Revision 1.0c

The information in this User's Manual has been carefully reviewed and is believed to be accurate. The vendor assumes no responsibility for any inaccuracies that may be contained in this document, makes no commitment to update or to keep current the information in this manual, or to notify any person or organization of the updates. **Please Note: For the most up-to-date version of this manual, please see our web site at www.supermicro.com.**

Super Micro Computer, Inc. ("Supermicro") reserves the right to make changes to the product described in this manual at any time and without notice. This product, including software and documentation, is the property of Supermicro and/or its licensors, and is supplied only under a license. Any use or reproduction of this product is not allowed, except as expressly permitted by the terms of said license.

IN NO EVENT WILL SUPERMICRO BE LIABLE FOR DIRECT, INDIRECT, SPECIAL, INCIDENTAL, SPECULATIVE OR CONSEQUENTIAL DAMAGES ARISING FROM THE USE OR INABILITY TO USE THIS PRODUCT OR DOCUMENTATION, EVEN IF ADVISED OF THE POSSIBILITY OF SUCH DAMAGES. IN PARTICULAR, SUPERMICRO SHALL NOT HAVE LIABILITY FOR ANY HARDWARE, SOFTWARE, OR DATA STORED OR USED WITH THE PRODUCT, INCLUDING THE COSTS OF REPAIRING, REPLACING, INTEGRATING, INSTALLING OR RECOVERING SUCH HARDWARE, SOFTWARE, OR DATA.

Any disputes arising between manufacturer and customer shall be governed by the laws of Santa Clara County in the State of California, USA. The State of California, County of Santa Clara shall be the exclusive venue for the resolution of any such disputes. Super Micro's total liability for all claims will not exceed the price paid for the hardware product.

FCC Statement: This equipment has been tested and found to comply with the limits for a Class A or Class B digital device pursuant to Part 15 of the FCC Rules. These limits are designed to provide reasonable protection against harmful interference when the equipment is operated in industrial environment for Class A device or in residential environment for Class B device. This equipment generates, uses, and can radiate radio frequency energy and, if not installed and used in accordance with the manufacturer's instruction manual, may cause harmful interference with radio communications. Operation of this equipment in a residential area is likely to cause harmful interference, in which case you will be required to correct the interference at your own expense.

California Best Management Practices Regulations for Perchlorate Materials: This Perchlorate warning applies only to products containing CR (Manganese Dioxide) Lithium coin cells. "Perchlorate Material-special handling may apply. See www.dtsc.ca.gov/hazardouswaste/perchlorate".



WARNING: This product can expose you to chemicals including lead, known to the State of California to cause cancer and birth defects or other reproductive harm. For more information, go to www.P65Warnings.ca.gov.

Manual Revision 1.0c

Release Date: June 04, 2021

mk

Unless you request and receive written permission from Super Micro Computer, Inc., you may not copy any part of this document.

Information in this document is subject to change without notice. Other products and companies referred to herein are trademarks or registered trademarks of their respective companies or mark holders.

Copyright © 2021 by Super Micro Computer, Inc.

All rights reserved.

Printed in the United States of America

Preface

About this Manual

This manual is written for professional system integrators and PC technicians. It provides information for the installation and use of the chassis. Installation and maintenance should be performed by experienced technicians only.

This document lists compatible parts available when this document was published. Refer to the Supermicro web site for updates on supported parts and configurations

This manual may be periodically updated without notice. Please check the Supermicro Web site for possible updates.

Warnings

Special attention should be given to the following symbols used in this manual.



Warning! Indicates important information given to prevent equipment/property damage or personal injury.



Warning! Indicates high voltage may be encountered when performing a procedure.

Contents

Chapter 1 Introduction.....	1-1
1-1 Overview	1-1
1-2 Shipping List.....	1-1
1-3 Components.....	1-2
Drives	1-2
Power Supply.....	1-2
Cooling	1-2
Control Board.....	1-2
Mounting Rails	1-2
1-4 Where to get Replacement Components.....	1-2
1-5 Returning Merchandise for Service.....	1-3
1-6 Contacting Supermicro	1-4
Chapter 2 Standardized Warning Statements for AC Systems.....	2-1
About Standardized Warning Statements	2-1
Warning Definition.....	2-1
Installation Instructions.....	2-4
Circuit Breaker	2-5
Power Disconnection Warning.....	2-6
Equipment Installation.....	2-8
Restricted Area.....	2-9
Battery Handling.....	2-10
Redundant Power Supplies	2-12
Backplane Voltage	2-13
Comply with Local and National Electrical Codes.....	2-14
Product Disposal.....	2-15
Hot Swap Fan Warning.....	2-16
Power Cable and AC Adapter	2-18
Chapter 3 System Interface.....	3-1
3-1 Overview	3-1
3-2 Control Panel Buttons.....	3-2
Power	3-2
(UID and BMC) Reset Button	3-2
3-3 Control Panel LEDs	3-2
Power	3-2
NIC1	3-2
Information LED	3-3

Power Fail	3-3
Overheating.....	3-3
3-4 Drive Carrier LEDs.....	3-4
3-5 Power Supply LEDs	3-4
Chapter 4 Chassis Setup and Maintenance	4-1
4-1 Overview	4-1
4-2 Power Up/Power Down Sequences.....	4-2
Power Up	4-2
First Use or Power Cord Plug-In.....	4-2
After Normal Shutdown by BMC or Power Button.....	4-2
After a Power Loss.....	4-2
Power Down.....	4-2
Removing Power from the System	4-3
4-3 Cable Connections.....	4-3
BMC LAN Connection.....	4-3
SAS Cables.....	4-4
Cascading Storage.....	4-5
4-4 Removing the Chassis Cover	4-7
4-5 Installing Hard Drives.....	4-8
4-6 System Fans	4-11
4-7 Power Supply	4-13
4-8 Control Board.....	4-15
4-9 Removing and Installing the Backplanes.....	4-16
Chapter 5 Rack Installation.....	5-1
5-1 Unpacking the System.....	5-1
5-2 Preparing for Setup.....	5-1
Choosing a Setup Location.....	5-1
5-3 Warnings and Precautions.....	5-2
Rack Precautions.....	5-2
General Server Precautions.....	5-2
Rack Mounting Considerations	5-3
Ambient Operating Temperature	5-3
Sufficient Airflow	5-3
Circuit Overloading.....	5-3
Reliable Ground	5-3
5-4 Installing the Rails	5-4
Identifying the Rails	5-4
Releasing the Inner Rail	5-5
Installing the Inner Rails on the Chassis	5-6

Installing the Outer Rails onto the Rack.....	5-8
Installing the Chassis into a Rack.....	5-9
Removing the Chassis from the Rack.....	5-10
Chapter 6 CSE-PTJBOD-CB3 Control Board.....	6-1
6-1 Overview	6-1
6-2 Safety Guidelines	6-1
ESD Safety Guidelines	6-1
General Safety Guidelines	6-2
6-3 Components, Connectors, Jumpers and LEDs	6-2
Component and Connector Definitions	6-3
Jumpers and LED Indicators.....	6-4
6-4 I ² C Cabling to the Backplane.....	6-6
6-5 JBOD Power Up/Power Down Sequences	6-7
Power Up	6-7
Power Down.....	6-7
6-6 BMC	6-8
BMC ADMIN User Password	6-8
IP Address.....	6-8
Appendix A SC847 JBOD Power Supply Specifications.....	A-1
Appendix B Compliance.....	B-1
Appendix C BPN-SAS3-846EL Backplane Specifications.....	C-1
Appendix D BPN-SAS3-847EL Backplane Specifications.....	D-1

Chapter 1

Introduction

1-1 Overview

Optimized for enterprise-level heavy-capacity storage applications, Supermicro's SC847 JBOD chassis features up to 44 hot-swap 3.5" drive bays. The CSE-847E2C-R1K23JBOD model offers two expanders for high availability.

Just install hard drives and use an external SAS cable and connect to a host bus adapter (HBA) on the head node server. The storage capacity can be expanded instantly and reduce the initial investment.

The chassis is equipped with a redundant, efficient power supply for outstanding power savings, with specially designed optimized cooling. Quick release, tool-less slide rails are available for quick installation.

SC847 JBOD Chassis Models		
Model	HDD	Power Supply
CSE-847E1C-R1K23JBOD	44x SAS/SATA	1200W redundant (Titanium Level)
CSE-847E2C-R1K23JBOD	44x SAS	1200W redundant (Titanium Level)

The following safety models associated with the SC847 JBOD have been certified as compliant with UL or CSA: 847JBOD-12.

1-2 Shipping List

Refer to the Supermicro website for the latest shipping lists and part numbers for your chassis model.

1-3 Components

The SC847 JBOD 4U high-performance chassis includes the following features:

Drives

The chassis supports forty-four hot-swap 3.5" SAS or SATA hard disk drives, 24 in the front and 20 in the rear. The drives are supported by two backplanes.

Power Supply

The chassis features two redundant digital power supplies, each 1200 watts with a Titanium 80-Plus efficiency certification level.

Cooling

The chassis includes seven mid-chassis, hot-plug 80 mm heavy-duty, hot-swap fans. System fans are powered and controlled by the BMC using 4-pin connectors.

Control Board

The JBOD control board allows the user to remotely control and monitor the chassis resources using BMC, such as powering on or off, controlling fan speeds and reading temperature data from the backplane.

Mounting Rails

Rack mount rails allow you to mount the chassis in a rack. The rails feature snap-in installation and quick release, and support modern square hole racks. Round hole rack are supported with a conversion kit.

1-4 Where to get Replacement Components

If you need replacement parts for your system, to ensure the highest level of professional service and technical support, purchase exclusively from our Supermicro Authorized Distributors/System Integrators/Resellers. A list can be found at: <http://www.supermicro.com>. Click the "Where to Buy" link.

1-5 Returning Merchandise for Service

A receipt or copy of your invoice marked with the date of purchase is required before any warranty service will be rendered. You can obtain service by calling your vendor for a Returned Merchandise Authorization (RMA) number. When returning to the manufacturer, the RMA number should be prominently displayed on the outside of the shipping carton, and mailed prepaid or hand-carried. Shipping and handling charges will be applied for all orders that must be mailed when service is complete.

For faster service, RMA authorizations may be requested online (<http://www.supermicro.com/support/rma/>).

Whenever possible, repack the chassis in the original Supermicro carton, using the original packaging material. If these are no longer available, be sure to pack the chassis securely, using packaging material to surround the chassis so that it does not shift within the carton and become damaged during shipping.

This warranty only covers normal consumer use and does not cover damages incurred in shipping or from failure due to the alteration, misuse, abuse or improper maintenance of products.

During the warranty period, contact your distributor first for any product problems.

1-6 Contacting Supermicro

Headquarters

Address: Super Micro Computer, Inc.
980 Rock Ave.
San Jose, CA 95131 U.S.A.

Tel: +1 (408) 503-8000

Fax: +1 (408) 503-8008

Email: marketing@supermicro.com (General Information)
support@supermicro.com (Technical Support)

Web Site: www.supermicro.com

Europe

Address: Super Micro Computer B.V.
Het Sterrenbeeld 28, 5215 ML
's-Hertogenbosch, The Netherlands

Tel: +31 (0) 73-6400390

Fax: +31 (0) 73-6416525

Email: sales@supermicro.nl (General Information)
support@supermicro.nl (Technical Support)
rma@supermicro.nl (Customer Support)

Web Site: www.supermicro.nl

Asia-Pacific

Address: Super Micro Computer, Inc.
3F, No. 150, Jian 1st Rd.
Zhonghe Dist., New Taipei City 235
Taiwan (R.O.C)

Tel: +886-(2) 8226-3990

Fax: +886-(2) 8226-3992

Email: support@supermicro.com.tw

Web Site: www.supermicro.com.tw

Chapter 2

Standardized Warning Statements for AC Systems

About Standardized Warning Statements

The following statements are industry standard warnings, provided to warn the user of situations which have the potential for bodily injury. Should you have questions or experience difficulty, contact Supermicro's Technical Support department for assistance. Only certified technicians should attempt to install or configure components.

Read this appendix in its entirety before installing or configuring components in the Supermicro chassis.

These warnings may also be found on our web site at http://www.supermicro.com/about/policies/safety_information.cfm.

Warning Definition



Warning!

This warning symbol means danger. You are in a situation that could cause bodily injury. Before you work on any equipment, be aware of the hazards involved with electrical circuitry and be familiar with standard practices for preventing accidents.

警告の定義

この警告サインは危険を意味します。

人身事故につながる可能性がありますので、いずれの機器でも動作させる前に、電気回路に含まれる危険性に注意して、標準的な事故防止策に精通して下さい。

此警告符号代表危險。

您正處於可能受到嚴重傷害的工作環境中。在您使用設備開始工作之前，必須充分意識到觸電的危險，並熟練掌握防止事故發生的標準工作程序。請根據每項警告結尾的聲明號碼找到此設備的安全性警告說明的翻譯文本。

此警告符號代表危險。

您正處於可能身體可能會受損傷的工作環境中。在您使用任何設備之前，請注意觸電的危險，並且要熟悉預防事故發生的標準工作程序。請依照每一注意事項後的號碼找到相關的翻譯說明內容。

Warnung

WICHTIGE SICHERHEITSHINWEISE

Dieses Warnsymbol bedeutet Gefahr. Sie befinden sich in einer Situation, die zu Verletzungen führen kann. Machen Sie sich vor der Arbeit mit Geräten mit den Gefahren elektrischer Schaltungen und den üblichen Verfahren zur Vorbeugung vor Unfällen vertraut. Suchen Sie mit der am Ende jeder Warnung angegebenen Anweisungsnummer nach der jeweiligen Übersetzung in den übersetzten Sicherheitshinweisen, die zusammen mit diesem Gerät ausgeliefert wurden.

BEWAHREN SIE DIESE HINWEISE GUT AUF.

INSTRUCCIONES IMPORTANTES DE SEGURIDAD

Este símbolo de aviso indica peligro. Existe riesgo para su integridad física. Antes de manipular cualquier equipo, considere los riesgos de la corriente eléctrica y familiarícese con los procedimientos estándar de prevención de accidentes. Al final de cada advertencia encontrará el número que le ayudará a encontrar el texto traducido en el apartado de traducciones que acompaña a este dispositivo.

GUARDE ESTAS INSTRUCCIONES.

IMPORTANTES INFORMATIONS DE SÉCURITÉ

Ce symbole d'avertissement indique un danger. Vous vous trouvez dans une situation pouvant entraîner des blessures ou des dommages corporels. Avant de travailler sur un équipement, soyez conscient des dangers liés aux circuits électriques et familiarisez-vous avec les procédures couramment utilisées pour éviter les accidents. Pour prendre connaissance des traductions des avertissements figurant dans les consignes de sécurité traduites qui accompagnent cet appareil, référez-vous au numéro de l'instruction situé à la fin de chaque avertissement.

CONSERVEZ CES INFORMATIONS.

תקנת הצהרות אזהרה

הצהרות הבאות הן אזהרות על פי תקני התעשייה, על מנת להזהיר את המשתמש מפני חבלה פיזית אפשרית. במידה ויש שאלות או היתקלות בבעיה כלשהי, יש ליצור קשר עם מחלקת תמיכה טכנית של סופרמיקרו. טכנאים מוסמכים בלבד רשאים להתקין או להגדיר את הרכיבים.

יש לקרוא את הנספח במלואו לפני התקנת או הגדרת הרכיבים במארוזי סופרמיקרו.

تحذير! هذا الرمز يعني خطر انك في حالة يمكن أن تتسبب في اصابة جسدية .
قبل أن تعمل على أي معدات، كن على علم بالمخاطر الناجمة عن الدوائر
الكهربائية
وكن على دراية بالممارسات الوقائية لمنع وقوع أي حوادث
استخدم رقم البيان المنصوص في نهاية كل تحذير للعثور ترجمتها

안전을 위한 주의사항

경고!

이 경고 기호는 위험이 있음을 알려 줍니다. 작업자의 신체에 부상을 야기 할 수 있는 상태에 있게 됩니다. 모든 장비에 대한 작업을 수행하기 전에 전기회로와 관련된 위험요소들을 확인하시고 사전에 사고를 방지할 수 있도록 표준 작업절차를 준수해 주시기 바랍니다.

해당 번역문을 찾기 위해 각 경고의 마지막 부분에 제공된 경고문 번호를 참조하십시오

BELANGRIJKE VEILIGHEIDSINSTRUCTIES

Dit waarschuwings symbool betekent gevaar. U verkeert in een situatie die lichamelijk letsel kan veroorzaken. Voordat u aan enige apparatuur gaat werken, dient u zich bewust te zijn van de bij een elektrische installatie betrokken risico's en dient u op de hoogte te zijn van de standaard procedures om ongelukken te voorkomen. Gebruik de nummers aan het eind van elke waarschuwing om deze te herleiden naar de desbetreffende locatie.

BEWAAR DEZE INSTRUCTIES

Installation Instructions



Warning!

Read the installation instructions before connecting the system to the power source.

設置手順書

システムを電源に接続する前に、設置手順書をお読み下さい。

警告

将此系统连接电源前,请先阅读安装说明。

警告

將系統與電源連接前·請先閱讀安裝說明。

Warnung

Vor dem Anschließen des Systems an die Stromquelle die Installationsanweisungen lesen.

¡Advertencia!

Lea las instrucciones de instalación antes de conectar el sistema a la red de alimentación.

Attention

Avant de brancher le système sur la source d'alimentation, consulter les directives d'installation.

יש לקרוא את הוראות התקנה לפני חיבור המערכת למקור מתח.

اقر إرشادات التركيب قبل توصيل النظام إلى مصدر للطاقة

시스템을 전원에 연결하기 전에 설치 안내를 읽어주시시오.

Waarschuwing

Raadpleeg de installatie-instructies voordat u het systeem op de voedingsbron aansluit.

Circuit Breaker



Warning!

This product relies on the building's installation for short-circuit (overcurrent) protection. Ensure that the protective device is rated not greater than: 250 V, 20 A.

サーキット・ブレーカー

この製品は、短絡(過電流)保護装置がある建物での設置を前提としています。

保護装置の定格が250 V、20 Aを超えないことを確認下さい。

警告

此产品的短路(过载电流)保护由建筑物的供电系统提供,确保短路保护设备的额定电流不大于250V,20A。

警告

此產品的短路(過載電流)保護由建築物的供電系統提供,確保短路保護設備的額定電流不大於250V,20A。

Warnung

Dieses Produkt ist darauf angewiesen, dass im Gebäude ein Kurzschluss- bzw. Überstromschutz installiert ist. Stellen Sie sicher, dass der Nennwert der Schutzvorrichtung nicht mehr als: 250 V, 20 A beträgt.

¡Advertencia!

Este equipo utiliza el sistema de protección contra cortocircuitos (o sobrecorrientes) del edificio. Asegúrese de que el dispositivo de protección no sea superior a: 250 V, 20 A.

Attention

Pour ce qui est de la protection contre les courts-circuits (surtension), ce produit dépend de l'installation électrique du local. Vérifiez que le courant nominal du dispositif de protection n'est pas supérieur à :250 V, 20 A.

מוצר זה מסתמך על הגנה המותקנת במבנים למניעת קצר חשמלי. יש לוודא כי המכשיר המגן מפני הקצר החשמלי הוא לא יותר מ-250 V, 20 A

هذا المنتج يعتمد على معدات الحماية من الدوائر القصيرة التي تم تثبيتها في المبنى

تأكد من أن تقييم الجهاز الوقائي ليس أكثر من: 20A, 250V

경고!

이 제품은 전원의 단락(과전류)방지에 대해서 전적으로 건물의 관련 설비에 의존합니다. 보호장치의 정격이 반드시 250V(볼트), 20A(암페어)를 초과하지 않도록 해야 합니다.

Waarschuwing

Dit product is afhankelijk van de kortsluitbeveiliging (overspanning) van uw elektrische installatie. Controleer of het beveiligde apparaat niet groter gedimensioneerd is dan 220V, 20A.

Power Disconnection Warning



Warning!



The system must be disconnected from all sources of power and the power cord removed from the power supply module(s) before accessing the chassis interior to install or remove system components.

電源切断の警告

システムコンポーネントの取り付けまたは取り外しのために、シャーシ内部にアクセスするには、

システムの電源はすべてのソースから切断され、電源コードは電源モジュールから取り外す必要があります。

警告

在你打开机箱并安装或移除内部器件前,必须将系统完全断电,并移除电源线。

警告

在您打開機殼安裝或移除內部元件前，必須將系統完全斷電，並移除電源線。

Warnung

Das System muss von allen Quellen der Energie und vom Netzanschlusskabel getrennt sein, das von den Spg.Versorgungsteilmodulen entfernt wird, bevor es

auf den Chassisinnenraum zurückgreift, um Systemsbestandteile anzubringen oder zu entfernen.

¡Advertencia!

El sistema debe ser disconnected de todas las fuentes de energía y del cable eléctrico quitado de los módulos de fuente de alimentación antes de tener acceso el interior del chasis para instalar o para quitar componentes de sistema.

Attention

Le système doit être débranché de toutes les sources de puissance ainsi que de son cordon d'alimentation secteur avant d'accéder à l'intérieur du chasis pour installer ou enlever des composants de système.

אזהרה!

יש לנתק את המערכת מכל מקורות החשמל ויש להסיר את כבל החשמלי מהספק לפני גישה לחלק הפנימי של המארז לצורך התקנת או הסרת רכיבים.

يجب فصل النظام من جميع مصادر الطاقة وإزالة سلك الكهرباء من وحدة امداد الطاقة قبل الوصول إلى المناطق الداخلية للهيكल لتثبيت أو إزالة مكونات الجهاز

경고!

시스템에 부품들을 장착하거나 제거하기 위해서는 새시 내부에 접근하기 전에 반드시 전원 공급장치로부터 연결되어있는 모든 전원과 전기코드를 분리해주어야 합니다.

Waarschuwing

Voordat u toegang neemt tot het binnenwerk van de behuizing voor het installeren of verwijderen van systeem onderdelen, dient u alle spanningsbronnen en alle stroomkabels aangesloten op de voeding(en) van de behuizing te verwijderen

Equipment Installation



Warning!

Only trained and qualified personnel should be allowed to install, replace, or service this equipment.

機器の設置

トレーニングを受け認定された人だけがこの装置の設置、交換、またはサービスを許可されています。

警告

只有经过培训且具有资格的人员才能进行此设备的安装、更换和维修。

警告

只有經過受訓且具資格人員才可安裝、更換與維修此設備。

Warnung

Das Installieren, Ersetzen oder Bedienen dieser Ausrüstung sollte nur geschultem, qualifiziertem Personal gestattet werden.

¡Advertencia!

Solamente el personal calificado debe instalar, reemplazar o utilizar este equipo.

Attention

Il est vivement recommandé de confier l'installation, le remplacement et la maintenance de ces équipements à des personnels qualifiés et expérimentés.

אזהרה!

צוות מוסמך בלבד רשאי להתקין, להחליף את הציוד או לתת שירות עבור הציוד.

يجب أن يسمح فقط للموظفين المؤهلين والمدربين لتثبيت واستبدال أو خدمة هذا الجهاز

경고!

훈련을 받고 공인된 기술자만이 이 장비의 설치, 교체 또는 서비스를 수행할 수 있습니다.

Waarschuwing

Deze apparatuur mag alleen worden geïnstalleerd, vervangen of hersteld door geschoold en gekwalificeerd personeel.

Restricted Area



Warning!

This unit is intended for installation in restricted access areas. A restricted access area can be accessed only through the use of a special tool, lock and key, or other means of security. (This warning does not apply to workstations).

アクセス制限区域

このユニットは、アクセス制限区域に設置されることを想定しています。

アクセス制限区域は、特別なツール、鍵と錠前、その他のセキュリティの手段を用いてのみ出入りが可能です。

警告

此部件应安装在限制进出的场所。限制进出的场所指只能通过使用特殊工具、锁和钥匙或其它安全手段进出的场所。

警告

此装置仅限安装于进出管制区域。进出管制区域係指仅能以特殊工具、锁头及钥匙或其他安全方式才能进入的区域。

Warnung

Diese Einheit ist zur Installation in Bereichen mit beschränktem Zutritt vorgesehen. Der Zutritt zu derartigen Bereichen ist nur mit einem Spezialwerkzeug, Schloss und Schlüssel oder einer sonstigen Sicherheitsvorkehrung möglich.

¡Advertencia!

Esta unidad ha sido diseñada para instalación en áreas de acceso restringido. Sólo puede obtenerse acceso a una de estas áreas mediante la utilización de una herramienta especial, cerradura con llave u otro medio de seguridad.

Attention

Cet appareil doit être installée dans des zones d'accès réservés. L'accès à une zone d'accès réservé n'est possible qu'en utilisant un outil spécial, un mécanisme de verrouillage et une clé, ou tout autre moyen de sécurité.

אזור עם גישה מוגבלת

אזהרה!

יש להתקין את היחידה באזורים שיש בהם הגבלת גישה. הגישה ניתנת בעזרת כלי אבטחה בלבד (מפתח, מנעול וכד').

تم تخصيص هذه الوحدة لت تركيبها في مناطق محظورة .
يمكن الوصول إلى منطقة محظورة فقط من خلال استخدام أداة خاصة،
قفل ومفتاح أو أي وسيلة أخرى للأمان

경고!

이 장치는 접근이 제한된 구역에 설치하도록 되어 있습니다. 특수도구, 잠금 장치 및 키, 또는 기타 보안 수단을 통해서만 접근 제한 구역에 들어갈 수 있습니다.

Waarschuwing

Dit apparaat is bedoeld voor installatie in gebieden met een beperkte toegang. Toegang tot dergelijke gebieden kunnen alleen verkregen worden door gebruik te maken van speciaal gereedschap, slot en sleutel of andere veiligheidsmaatregelen.

Battery Handling



Warning!

There is the danger of explosion if the battery is replaced incorrectly. Replace the battery only with the same or equivalent type recommended by the manufacturer. Dispose of used batteries according to the manufacturer's instructions

電池の取り扱い

電池交換が正しく行われなかった場合、破裂の危険性があります。交換する電池はメーカーが推奨する型、または同等のものを使用下さい。使用済電池は製造元の指示に従って処分して下さい。

警告

電池更換不當會有爆炸危險。請只使用同類電池或製造商推薦的功能相當的電池更換原有電池。請按製造商的說明處理廢舊電池。

警告

電池更換不當會有爆炸危險。請使用製造商建議之相同或功能相當的電池更換原有電池。請按照製造商的說明指示處理廢棄舊電池。

Warnung

Bei Einsetzen einer falschen Batterie besteht Explosionsgefahr. Ersetzen Sie die Batterie nur durch den gleichen oder vom Hersteller empfohlenen Batterietyp. Entsorgen Sie die benutzten Batterien nach den Anweisungen des Herstellers.

Attention

Danger d'explosion si la pile n'est pas remplacée correctement. Ne la remplacer que par une pile de type semblable ou équivalent, recommandée par le fabricant. Jeter les piles usagées conformément aux instructions du fabricant.

¡Advertencia!

Existe peligro de explosión si la batería se reemplaza de manera incorrecta. Reemplazar la batería exclusivamente con el mismo tipo o el equivalente recomendado por el fabricante. Desechar las baterías gastadas según las instrucciones del fabricante.

אזהרה !

קיימת סכנת פיצוץ של הסוללה במידה והוחלפה בדרך לא תקינה. יש להחליף את הסוללה בסוג התואם מחברת יצרן מומלצת.

סילוק הסוללות המשומשות יש לבצע לפי הוראות היצרן.

هناك خطر من انفجار في حالة استبدال البطارية بطريقة غير صحيحة عليك استبدال البطارية فقط بنفس النوع أو ما يعادلها كما أوصت به الشركة المصنعة تخلص من البطاريات المستعملة وفقا لتعليمات الشركة الصانعة

경고!

배터리가 올바르게 교체되지 않으면 폭발의 위험이 있습니다. 기존 배터리와 동일하거나 제조사에서 권장하는 동등한 종류의 배터리로만 교체해야 합니다. 제조사의 안내에 따라 사용된 배터리를 처리하여 주십시오.

Waarschuwing

Er is ontploffingsgevaar indien de batterij verkeerd vervangen wordt. Vervang de batterij slechts met hetzelfde of een equivalent type die door de fabrikant aanbevolen wordt. Gebruikte batterijen dienen overeenkomstig fabrieksvoorschriften afgevoerd te worden.

Redundant Power Supplies



Warning!

This unit might have more than one power supply connection. All connections must be removed to de-energize the unit.



冗長電源装置

このユニットは複数の電源装置が接続されている場合があります。

ユニットの電源を切るためには、すべての接続を取り外さなければなりません。

警告

此部件连接的电源可能不止一个，必须将所有电源断开才能停止给该部件供电。

警告

此装置连接的电源可能不只一个，必须切断所有电源才能停止对该装置的供电。

Warnung

Dieses Gerät kann mehr als eine Stromzufuhr haben. Um sicherzustellen, dass der Einheit kein Strom zugeführt wird, müssen alle Verbindungen entfernt werden.

¡Advertencia!

Puede que esta unidad tenga más de una conexión para fuentes de alimentación. Para cortar por completo el suministro de energía, deben desconectarse todas las conexiones.

Attention

Cette unité peut avoir plus d'une connexion d'alimentation. Pour supprimer toute tension et tout courant électrique de l'unité, toutes les connexions d'alimentation doivent être débranchées.

אם קיים יותר מספק אחד

אזהרה!

ליחידה יש יותר מחיבור אחד של ספק. יש להסיר את כל החיבורים על מנת לרוקן את היחידה.

قد يكون لهذا الجهاز عدة اتصالات بوحدات امداد الطاقة.
يجب إزالة كافة الاتصالات لعزل الوحدة عن الكهرباء

경고!

이 장치에는 한 개 이상의 전원 공급 단자가 연결되어 있을 수 있습니다. 이 장치에 전원을 차단하기 위해서는 모든 연결 단자를 제거해야만 합니다.

Waarschuwing

Deze eenheid kan meer dan één stroomtoevoeraansluiting bevatten. Alle aansluitingen dienen verwijderd te worden om het apparaat stroomloos te maken.

Backplane Voltage



Warning!

Hazardous voltage or energy is present on the backplane when the system is operating. Use caution when servicing.

バックプレーンの電圧

システムの稼働中は危険な電圧または電力が、バックプレーン上にかかっています。

修理する際にはご注意ください。

警告

当系統正在进行时，背板上有很危险的电压或能量，进行维修时务必小心。

警告

當系統正在進行時，背板上有危險的電壓或能量，進行維修時務必小心。

Warnung

Wenn das System in Betrieb ist, treten auf der Rückwandplatine gefährliche Spannungen oder Energien auf. Vorsicht bei der Wartung.

¡Advertencia!

Cuando el sistema está en funcionamiento, el voltaje del plano trasero es peligroso. Tenga cuidado cuando lo revise.

Attention

Lorsque le système est en fonctionnement, des tensions électriques circulent sur le fond de panier. Prendre des précautions lors de la maintenance.

מתח בפנל האחורי

אזהרה!
קיימת סכנת מתח בפנל האחורי בזמן תפעול המערכת. יש להיזהר במהלך העבודה.

هناك خطر من التيار الكهربائي أو الطاقة الموجودة على اللوحة
عندما يكون النظام يعمل كن حذرا عند خدمة هذا الجهاز

경고!

시스템이 동작 중일 때 후면판 (Backplane)에는 위험한 전압이나 에너지가 발생
합니다. 서비스 작업 시 주의하십시오.

Waarschuwing

Een gevaarlijke spanning of energie is aanwezig op de backplane wanneer het
systeem in gebruik is. Voorzichtigheid is geboden tijdens het onderhoud.

Comply with Local and National Electrical Codes



Warning!

Installation of the equipment must comply with local and national electrical codes.

地方および国の電気規格に準拠

機器の取り付けはその地方および国の電気規格に準拠する必要があります。

警告

设备安装必须符合本地与本国电气法规。

警告

設備安裝必須符合本地與本國電氣法規。

Warnung

Die Installation der Geräte muss den Sicherheitsstandards entsprechen.

¡Advertencia!

La instalación del equipo debe cumplir con las normas de electricidad locales y
nacionales.

Attention

L'équipement doit être installé conformément aux normes électriques nationales et locales.

תיאום חוקי החשמל הארצי

אזהרה!

התקנת הציוד חייבת להיות תואמת לחוקי החשמל המקומיים והארציים.

تركيب المعدات الكهربائية يجب أن يمتثل للقوانين المحلية والوطنية المتعلقة بالكهرباء

경고!

현 지역 및 국가의 전기 규정에 따라 장비를 설치해야 합니다.

Waarschuwing

Bij installatie van de apparatuur moet worden voldaan aan de lokale en nationale elektriciteitsvoorschriften.

Product Disposal



Warning!

Ultimate disposal of this product should be handled according to all national laws and regulations.

製品の廃棄

この製品を廃棄処分する場合、国の関係する全ての法律・条例に従い処理する必要があります。

警告

本产品的废弃处理应根据所有国家的法律和规章进行。

警告

本產品的廢棄處理應根據所有國家的法律和規章進行。

Warnung

Die Entsorgung dieses Produkts sollte gemäß allen Bestimmungen und Gesetzen des Landes erfolgen.

¡Advertencia!

Al deshacerse por completo de este producto debe seguir todas las leyes y reglamentos nacionales.

Attention

La mise au rebut ou le recyclage de ce produit sont généralement soumis à des lois et/ou directives de respect de l'environnement. Renseignez-vous auprès de l'organisme compétent.

סילוק המוצר

!אזהרה!

סילוק סופי של מוצר זה חייב להיות בהתאם להנחיות וחוקי המדינה.

عند التخلص النهائي من هذا المنتج ينبغي التعامل معه وفقا لجميع القوانين واللوائح الوطنية

경고!

이 제품은 해당 국가의 관련 법규 및 규정에 따라 폐기되어야 합니다.

Waarschuwing

De uiteindelijke verwijdering van dit product dient te geschieden in overeenstemming met alle nationale wetten en reglementen.

Hot Swap Fan Warning



Warning!



Hazardous moving parts. Keep away from moving fan blades. The fans might still be turning when you remove the fan assembly from the chassis. Keep fingers, screwdrivers, and other objects away from the openings in the fan assembly's housing.

ファン・ホットスワップの警告

シャーシから冷却ファン装置を取り外した際、ファンがまだ回転している可能性があります。ファンの開口部に、指、ドライバー、およびその他のものを近づけないで下さい。

警告

当您从机架移除风扇装置，风扇可能仍在转动，小心不要将手指、螺丝起子和其他物品太靠近风扇

警告

當您從機架移除風扇裝置，風扇可能仍在轉動。小心不要將手指、螺絲起子和其他物品太靠近風扇。

Warnung

Die Lüfter drehen sich u. U. noch, wenn die Lüfterbaugruppe aus dem Chassis genommen wird. Halten Sie Finger, Schraubendreher und andere Gegenstände von den Öffnungen des Lüftergehäuses entfernt.

¡Advertencia!

Los ventiladores podran dar vuelta cuando usted quite el montaje del ventilador del chasis. Mantenga los dedos, los destornilladores y todos los objetos lejos de las aberturas del ventilador

Attention

Il est possible que les ventilateurs soient toujours en rotation lorsque vous retirez le bloc ventilateur du châssis. Prenez garde à ce que doigts, tournevis et autres objets soient éloignés du logement du bloc ventilateur.

הרה!

קים נעים מסוכנים. התרחק מלהבי המאוורר בפעולה כאשר את חלקי אוורר מהמארו, יתכן והמאווררים עדיין עובדים. יש להרחיק למרחק בטוח את

تحذیر! أجزاء متحركة خطيرة. ابتعد عن شفرات المروحة المتحركة من الممكن أن المراوح لا تزال تدور عند إزالة كتلة المروحة من الهيكل يجب إبقاء الأصابع ومفكات البراغي وغيرها من الأشياء بعيدا عن الفتحات في كتلة المروحة.

경고!

새시로부터 팬 조립품을 제거할 때 팬은 여전히 회전하고 있을 수 있습니다. 팬 조립품 외관의 열려있는 부분들로부터 손가락 및 스크류드라이버, 다른 물체들이 가까이 하지 않도록 배치해 주십시오.

Waarschuwing

Het is mogelijk dat de ventilator nog draait tijdens het verwijderen van het ventilatorsamenstel uit het chassis. Houd uw vingers, schroevendraaiers en eventuele andere voorwerpen uit de buurt van de openingen in de ventilatorbehuizing.

Power Cable and AC Adapter



Warning!

When installing the product, use the provided or designated connection cables, power cables and AC adaptors. Using any other cables and adaptors could cause a malfunction or a fire. Electrical Appliance and Material Safety Law prohibits the use of UL or CSA -certified cables (that have UL/CSA shown on the code) for any other electrical devices than products designated by Supermicro only.

電源コードとACアダプター

製品を設置する場合、提供または指定された接続ケーブル、電源コードとACアダプターを使用下さい。他のケーブルやアダプタを使用すると故障や火災の原因になることがあります。電気用品安全法は、ULまたはCSA認定のケーブル(UL/CSAマークがコードに表記)をSupermicroが指定する製品以外に使用することを禁止しています。

警告

安装此产品时,请使用本身提供的或指定的连接线,电源线和电源适配器.使用其它线材或适配器可能会引起故障或火灾。除了Supermicro所指定的产品,电气用品和材料安全法律规定禁止使用未经UL或CSA认证的线材。(线材上会显示UL/CSA符号)。

警告

安装此產品時,請使用本身提供的或指定的連接線,電源線和電源適配器.使用其它線材或適配器可能會引起故障或火災。除了Supermicro所指定的產品,電氣用品和材料安全法律規定禁止使用未經UL或CSA認證的線材。(線材上會顯示UL/CSA符號)。

Warnung

Bei der Installation des Produkts, die zur Verfügung gestellten oder benannt Anschlusskabel, Stromkabel und Netzteile. Verwendung anderer Kabel und Adapter kann zu einer Fehlfunktion oder ein Brand entstehen. Elektrische Geräte und Material Safety Law verbietet die Verwendung von UL-oder CSA-zertifizierte Kabel, UL oder CSA auf der Code für alle anderen elektrischen Geräte als Produkte von Supermicro nur bezeichnet gezeigt haben.

¡Advertencia!

Al instalar el producto, utilice los cables de conexión previstos o designados, los cables y adaptadores de CA. La utilización de otros cables y adaptadores podría ocasionar un mal funcionamiento o un incendio. Aparatos Eléctricos y la Ley de Seguridad del Material prohíbe el uso de UL o CSA cables certificados que tienen UL o CSA se muestra en el código de otros dispositivos eléctricos que los productos designados por Supermicro solamente.

Attention

Lors de l'installation du produit, utilisez les bables de connection fournis ou désigné. L'utilisation d'autres câbles et adaptateurs peut provoquer un dysfonctionnement ou un incendie. Appareils électroménagers et de loi sur la sécurité Matériel interdit l'utilisation de UL ou CSA câbles certifiés qui ont UL ou CSA indiqué sur le code pour tous les autres appareils électriques que les produits désignés par Supermicro seulement.

חשמליים ומתאמי AC**אזהרה!**

כאשר מתקינים את המוצר, יש להשתמש בכבלים, ספקים ומתאמים AC אשר נועדו וסופקו לשם כך. שימוש בכל כבל או מתאם אחר יכול לגרום לתקלה או קצר חשמלי. על פי חוקי שימוש במכשירי חשמל וחוקי בטיחות, קיים איסור להשתמש בכבלים המוסמכים ב- UL או ב- CSA (כשאר מופיע עליהם קוד של UL/CSA) עבור כל מוצר חשמלי אחר שלא צויין על ידי סופרמיקרו בלבד.

عند تركيب الجهاز يجب استخدام كابلات التوصيل، والكابلات الكهربائية ومحولات التيار المتردد التي . أن استخدام أي كابلات ومحولات أخرى يتسبب في حدوث عطل أو حريق. تم توفيرها لك مع المنتج الأجهزة الكهربائية ومواد قانون السلامة يحظر استخدام الكابلات CSA أو UL معتمدة من قبل لأي أجهزة كهربائية أخرى غير المنتجات المعينة من قبل Supermicro (التي تحمل علامة UL/CSA)

경고!

제품을 설치할 때에는 제공되거나 지정된 연결케이블과 전원케이블, AC 어댑터를 사용해야 합니다. 그 밖의 다른 케이블들이나 어댑터들은 고장 또는 화재의 원인이 될 수 있습니다. 전기용품안전법 (Electrical Appliance and Material Safety Law)은 슈퍼마이크로에서 지정한 제품들 외에는 그 밖의 다른 전기 장치들을 위한 UL 또는 CSA에서 인증한 케이블(전선 위에 UL/CSA가 표시)들의 사용을 금지합니다.

Waarschuwing

Bij het installeren van het product, gebruik de meegeleverde of aangewezen kabels, stroomkabels en adapters. Het gebruik van andere kabels en adapters kan leiden tot een storing of een brand. Elektrisch apparaat en veiligheidsinformatiebladen wet verbiedt het gebruik van UL of CSA gecertificeerde kabels die UL of CSA die op de code voor andere elektrische apparaten dan de producten die door Supermicro alleen.

Notes

Chapter 3

System Interface

3-1 Overview

The server includes a control panel on the front that houses power buttons and status monitoring lights. The externally accessible hard drives display status lights. The power supply displays status lights visible from the back of the chassis.

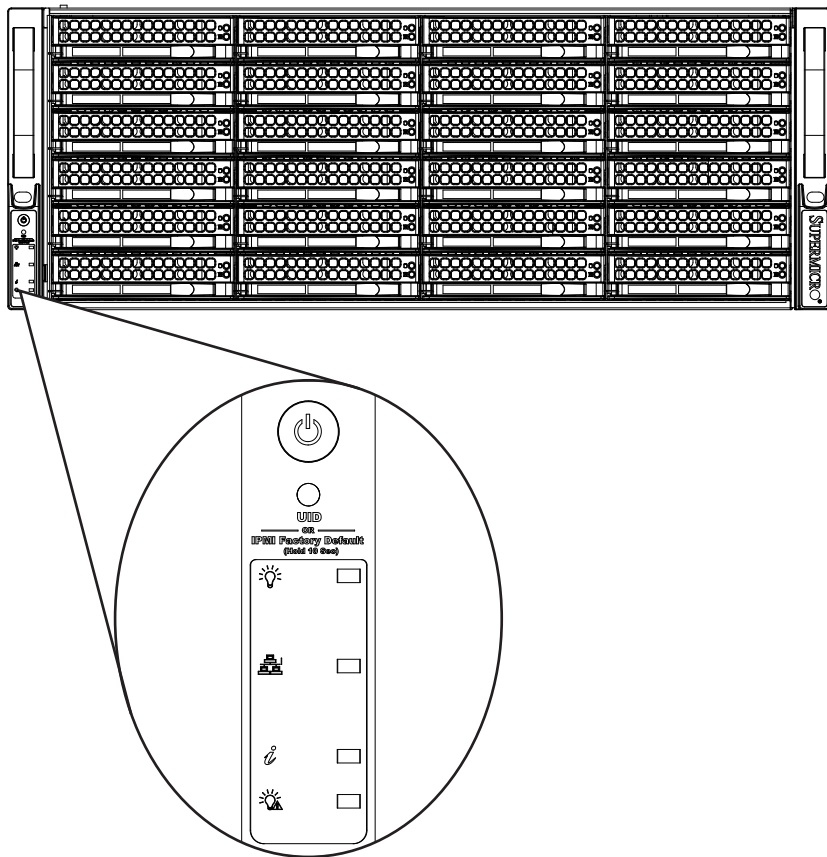

Figure 3-1. Front Control Panel

3-2 Control Panel Buttons

The chassis includes two push-buttons that control power to the system.



Power

The main power switch applies or removes primary power from the power supply to the JBOD Control Board but maintains standby power. To perform most maintenance tasks, unplug the system to remove all power.



(UID and BMC) Reset Button

- Press briefly to toggle the UID alert light. The blue LED will blink.
- Press and hold 6 seconds to set the BMC IP address to 192.168.1.99. The blue LED will blink.
- Press and hold 12 seconds to restore factory defaults. The blue LED will remain on.

3-3 Control Panel LEDs

There are four LEDs that provide status information about the system.



Power

Indicates power is being supplied to the system power supply units. This LED is illuminated when the system is operating normally.



NIC1

Indicates network activity on GLAN1 when flashing.



Information LED

Alerts operator to several states, as noted in the table below.

Information LED	
Status	Description
Continuously on and red	An overheat condition has occurred. (This may be caused by cable congestion.)
Blinking red (1Hz)	Fan failure, check for an inoperative fan.
Blinking red (0.25Hz)	Power failure, check for a non-operational power supply.
Solid blue	Local UID has been activated. Use this function to locate the server in a rack mount environment.
Blinking blue	Remote UID is on. Use this function to identify the server from a remote location.



Power Fail

Indicates a power supply module has failed.

Overheating

A sensor on the backplane will issue a warning at 45°C. Overheating is critical at 49°C. There are several possible responses if the system overheats.

If the server overheats:

1. Use the LEDs to determine the nature of the overheating condition.
2. Confirm that the chassis covers are installed properly.
3. Check the routing of the cables and make sure all fans are present and operating normally.

3-4 Drive Carrier LEDs

The SC847 JBOD chassis uses SAS or SATA drives. Each drive carrier has two LED indicators on the front, one blue and red. The LEDs function as follows:

Blue Drive Carrier LED Indicator		
Color	Status	Description
Blue	Steady on	Indicates a SAS drive
Blue	Off	Indicates a SATA drive
Blue	Blinking	Drive is actively being accessed

Red Drive Carrier LED Indicator		
Color	Status	Description
Red	Steady on	Drive failure
Red	Blinking	RAID activity

When the red LED is blinking, it indicates that the system is either building, initializing or rebuilding RAID.

3-5 Power Supply LEDs

On the rear of the power supply module, an LED displays the status.

- **Solid Green:** When illuminated, indicates that the power supply is on.
- **Solid Amber:** When illuminated, indicates the power supply is plugged in and turned off, or the system is off but in an abnormal state.
- **Blinking Amber:** When blinking, this system power supply temperature has reached 63C. The system will automatically power-down when the power supply temperature reaches 70C and restart when the power supply temperature goes below 60C.

Chapter 4

Chassis Setup and Maintenance

4-1 Overview

This chapter covers the steps required to install components and perform maintenance on the chassis. The only tool required is a Phillips screwdriver.

Review the warnings and precautions listed in the manual before setting up or servicing this chassis. These include information in Chapter 2: *Warning Statements for AC Systems* and the warning/precautions listed in the setup instructions.

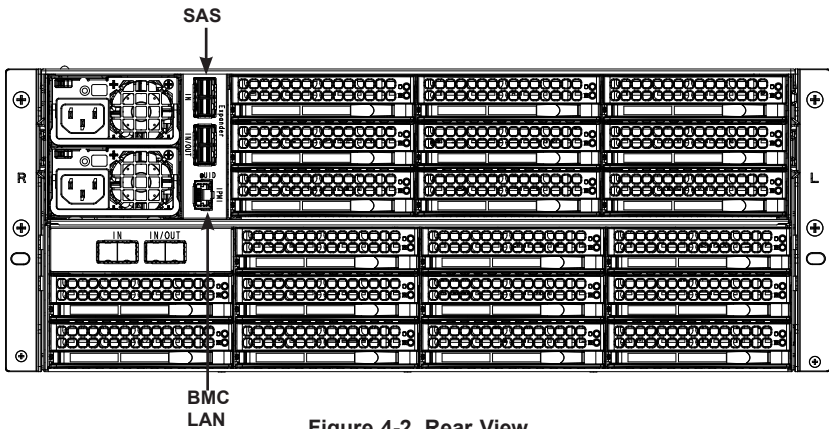
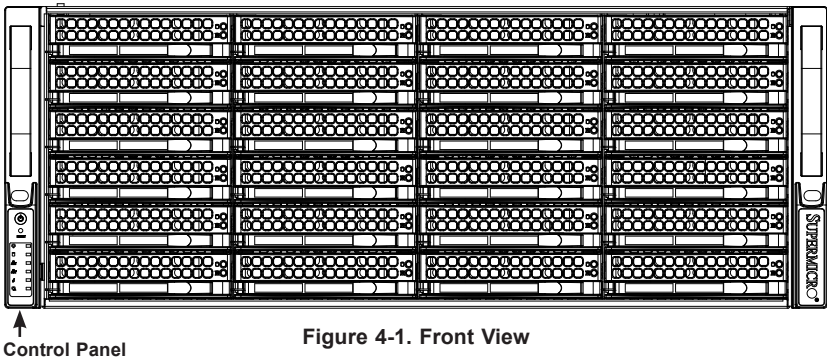

4-2 Power Up/Power Down Sequences

There are several procedures to turn on or off the system with the CB3 JBOD control board.

Power Up

First Use or Power Cord Plug-In

1. Plug the power cords into the rear of the power supplies.
2. Wait until blue Information LED starts to blink.
3. Press the power button once. The JBOD control board initiates the power up sequence in three seconds.

After Normal Shutdown by BMC or Power Button

Press the power button once. The JBOD control board will initiate the power up sequence in three seconds.

After a Power Loss

The system will power up automatically approximately 45 seconds after the power returns.

Power Down

1. Hold down the power button. The blue Information LED will begin blinking. Continue to hold the power button.
2. Release power button after blue LED stops blinking and goes dark.
3. The shutdown sequence will begin and shut down the system within ten seconds

Removing Power from the System

Before performing most setup or maintenance tasks, use the following procedure to ensure that power has been removed from the system.

1. After the system has completely shut-down, carefully grasp the head of the power cord and gently pull it out of the back of the power supply. If your system has dual power supplies, remove the cords from both power supplies.
2. Disconnect the cord from the power strip or wall outlet..

4-3 Cable Connections

BMC LAN Connection

The Control Board offers intelligent management with the baseboard management controller (BMC) providing hardware health monitoring and remote power control. To enable, connect to the storage enclosure using the dedicated BMC LAN connector (Figure 4-2).

For more information on the BMC, see Section 6-6 in this manual.

SAS Cables

This drawing shows connectors for SAS cabling. For primary and secondary, two connectors are marked **In**, and two connectors are marked **In/Out**.

Connect two mini-SAS HD cables (SFF-8644) from the head server node host bus adapter (HBA) card to the two Primary receptacles marked **In**. If using the E2C model (CSE-847E2C-R1K23JBOD) for redundancy, connect two more mini-SAS HD cables to the two Secondary receptacles also marked **In**. Cables are described in Appendix B.

To cascade out, connect cables from the two receptacles marked **In/Out** to the next JBOD storage enclosure. (see Figure 4-4 and 4-5)

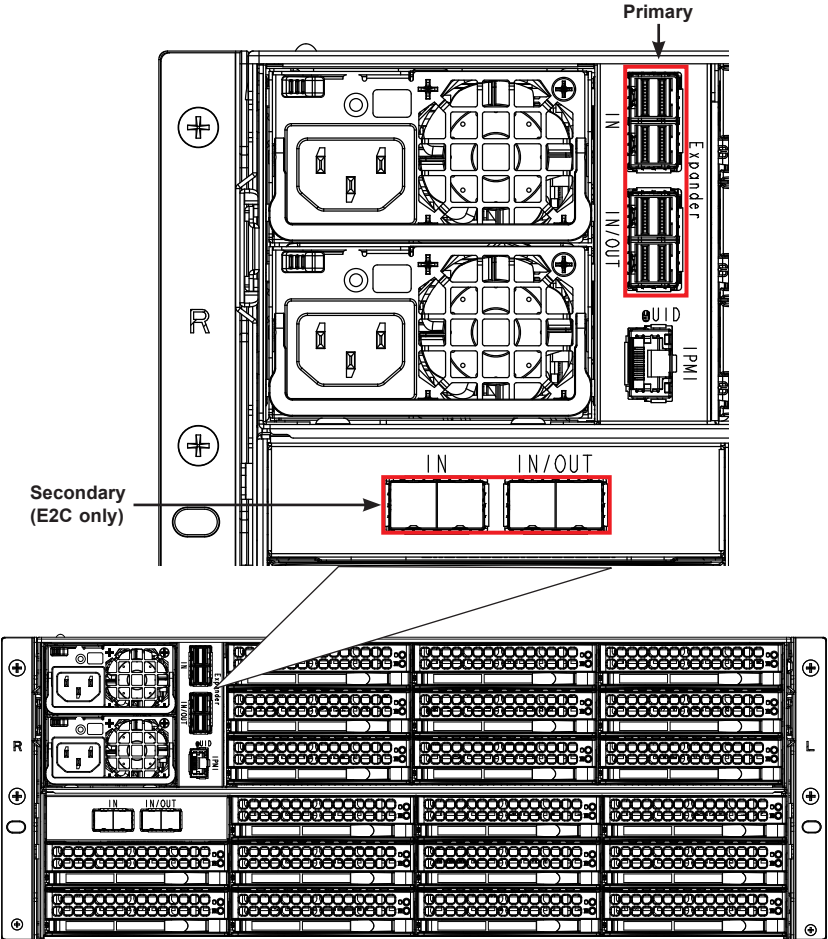

Figure 4-3. SAS Cables
(E1C model shown)

Cascading Storage

The following diagram shows a server with a single host bus adapter (HBA) and requires only the primary expander on the backplane. The SC847 JBOD storage enclosure model E1C can accommodate this configuration.

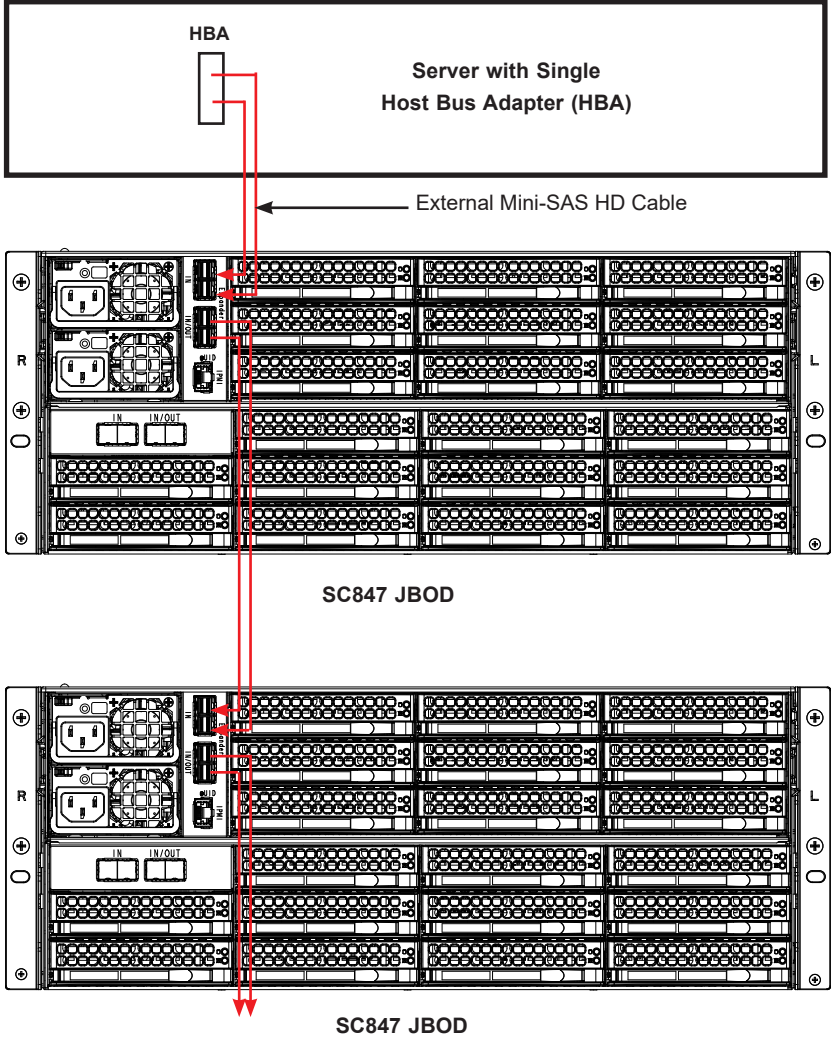

Figure 4-4. Sample Cascading Storage, Single HBA

The following diagram shows a server with dual HBAs and requires the primary and secondary expanders on the backplane. The SC847 JBOD storage enclosure model E2C accommodates this configuration.

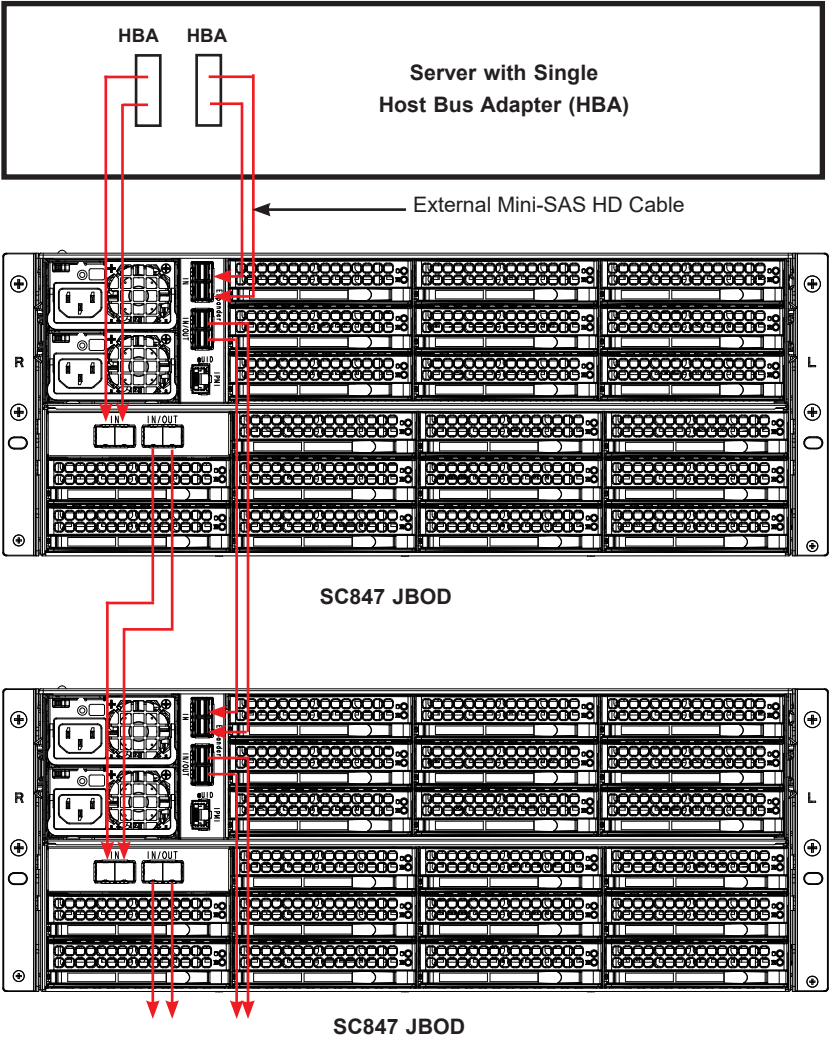

Figure 4-5. Sample Cascading Storage, Dual HBAs

4-4 Removing the Chassis Cover

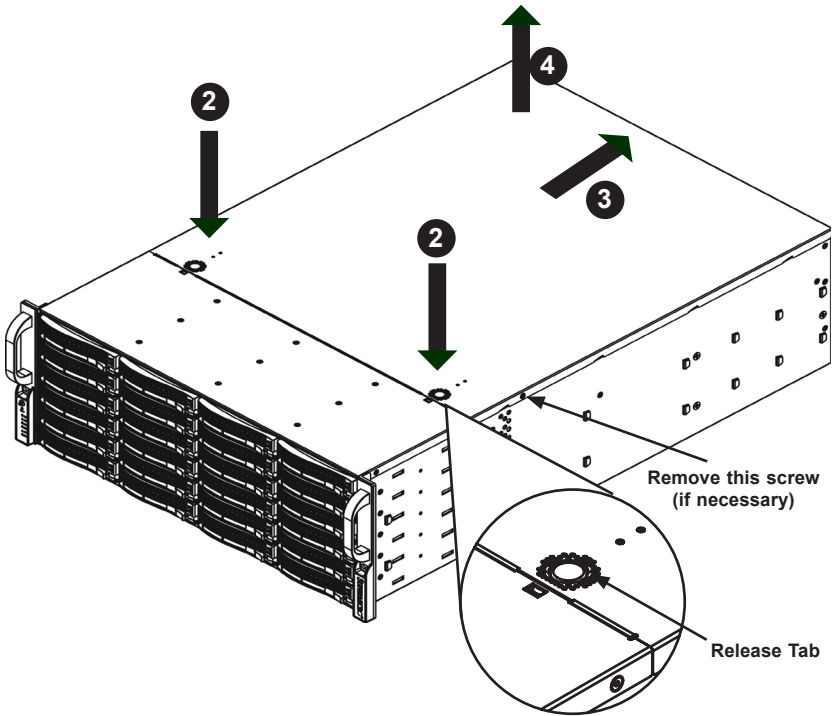

Figure 4-6. Removing the Chassis Cover

Removing the Chassis Cover

1. Power down the system and remove the power cords from the back of the power supplies.
2. Press the release tabs to remove the cover from the locked position. Press both tabs at the same time.
3. Once the top cover is released from the locked position, slide the cover toward the rear of the chassis.
4. Lift the cover off the chassis.

Caution: Except for short periods of time, do not operate the server without the cover in place. The chassis cover provides proper airflow and prevents overheating.

4-5 Installing Hard Drives

The drives are mounted in drive carriers to simplify their installation and removal from the chassis. These carriers also help promote proper airflow for the drive bays.

Caution: Except for short periods of time, such as swapping hard drives, do not operate the server with the hard drive bays empty.

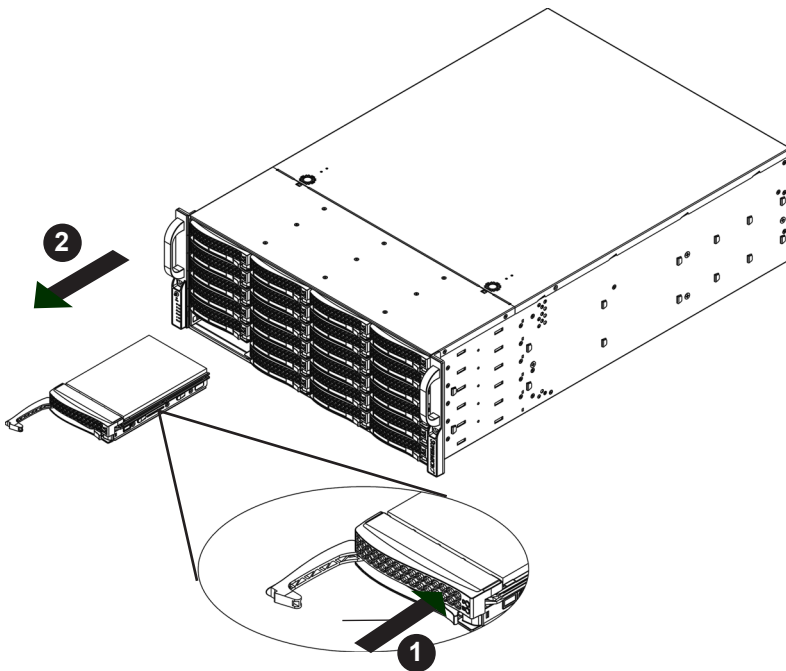

Figure 4-7. Removing a Hard Drive Carrier

Removing Hard Drive Carriers from the Chassis

1. Press the release button on the drive carrier. This extends the drive carrier handle.
2. Use the handle to pull the drive out of the chassis.

Place the drive carrier on a flat surface such as a desk, table or work bench.

Installing a Hard Drive

1. Remove the two screws securing the dummy drive to the drive carrier and remove the dummy drive.
2. Slide the hard drive into the carrier with the printed circuit board side facing down.

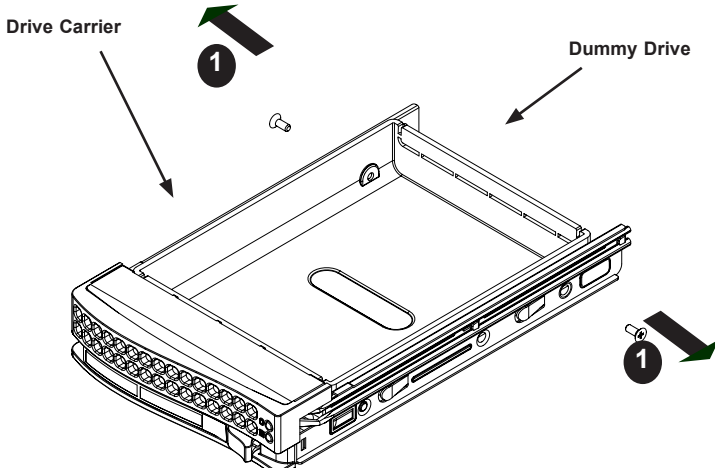

Figure 4-8. Removing a Dummy Drive from the Drive Carrier

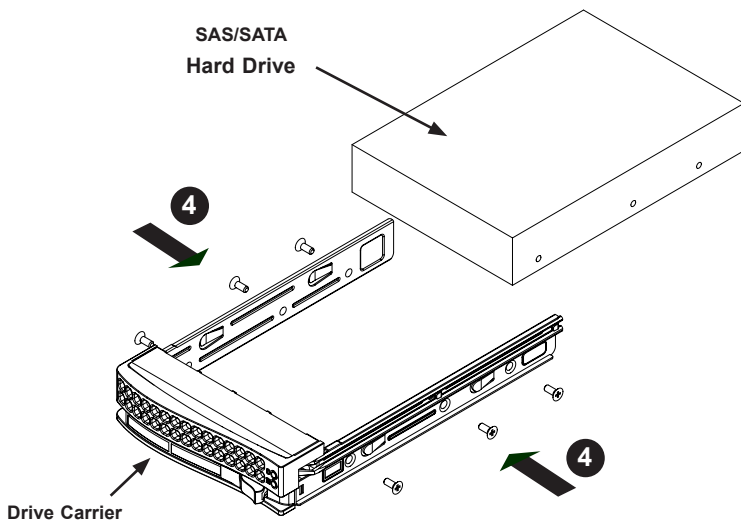

Figure 4-9. Installing the Hard Drive into the Drive Carrier

3. Carefully align the mounting holes in both the drive carrier and the hard drive.
4. Secure the hard drive to the carrier using six screws.
5. Replace the drive carrier into the chassis. Make sure to close the drive carrier handle to lock the drive carrier into place.

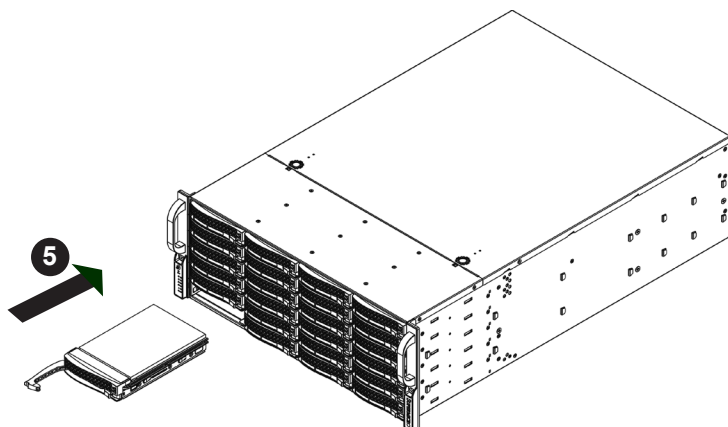

Figure 4-10. Installing the Hard Drive

4-6 System Fans

Seven heavy-duty hot-swap system fans provide cooling for the chassis.

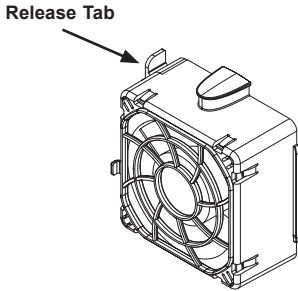

Figure 4-11. Mid-chassis Fan

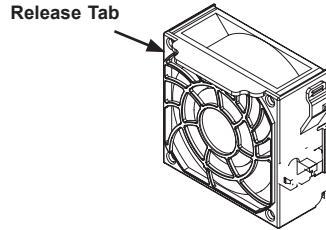

Figure 4-12. Rear Exhaust Fan

Replacing a System Fan

1. If necessary, open the chassis while the power is running to determine which fan has failed. (Never run the server for an extended period of time with the chassis open.)
2. Remove the failed fan's power cord from the JBOD control board.
3. Press the fan release tab to lift the failed fan from the chassis and pull it completely from the chassis.
4. Place the new fan into the vacant space in the housing making sure the arrows on the top of the fan, indicating air direction, point in the same direction as the arrows on the other fans.
5. Check that the fan is working properly before replacing the chassis cover.

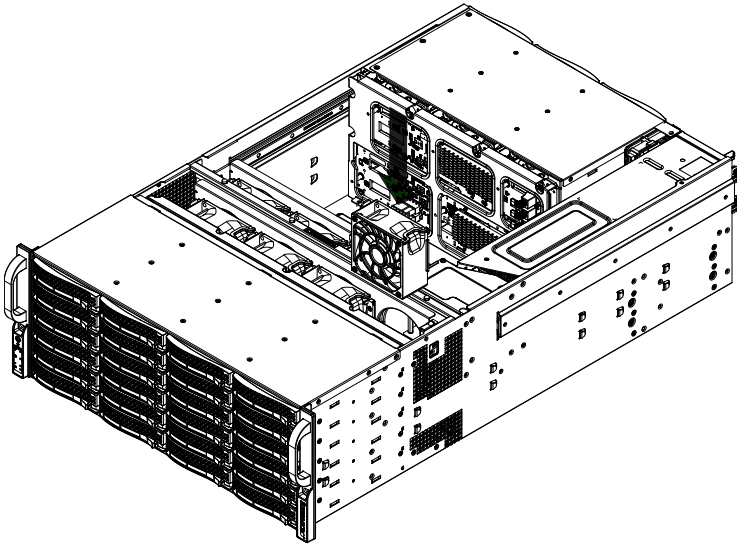

Figure 4-13. Placing a Mid-chassis Fan

4-7 Power Supply

The chassis features redundant power supplies. They are hot-swappable, meaning they can be changed without powering down the system. New units can be ordered directly from Supermicro or authorized distributors.

These power supplies are auto-switching capable. This feature enables them to automatically sense the input voltage and operate at a 100-120v or 180-240v. An amber light will be illuminated on the power supply when the power is off. An illuminated green light indicates that the power supply is operating.

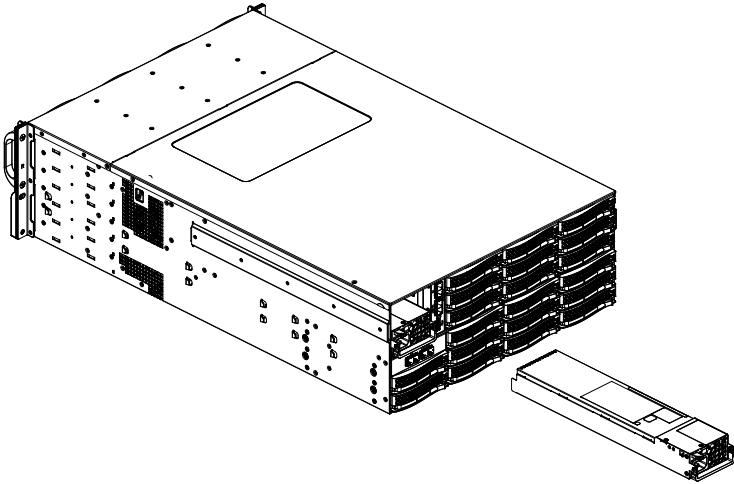

Figure 4-14. Power Supply

Changing the Power Supply:

1. Unplug the AC cord from the module to be replaced.
2. Push the release tab on the back of the power supply as illustrated.
3. Pull the power supply out using the handle provided.
4. Replace the failed power module with another of the same model.
5. Push the new power supply module into the power bay until it clicks into the locked position.
6. Plug the AC power cord back into the module.

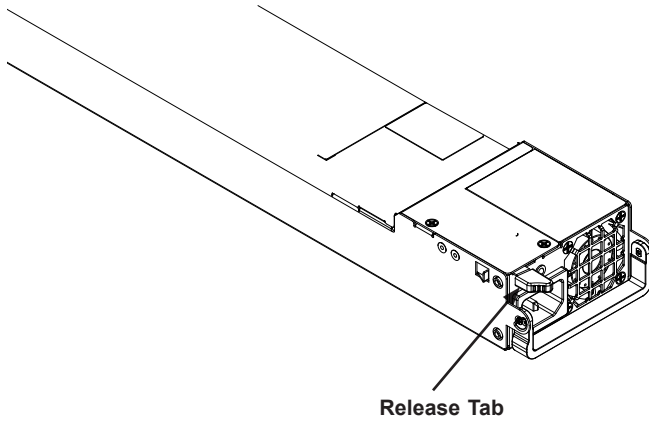

Figure 4-15. Power Supply Release Tab

4-8 Control Board

The JBOD control board (CSE-PTJBOD-CB3) allows the user to remotely control and monitor the chassis resources using the BMC, such as powering on or off, controlling fan speeds and reading temperature data from the backplane. The location is shown in the figure below.

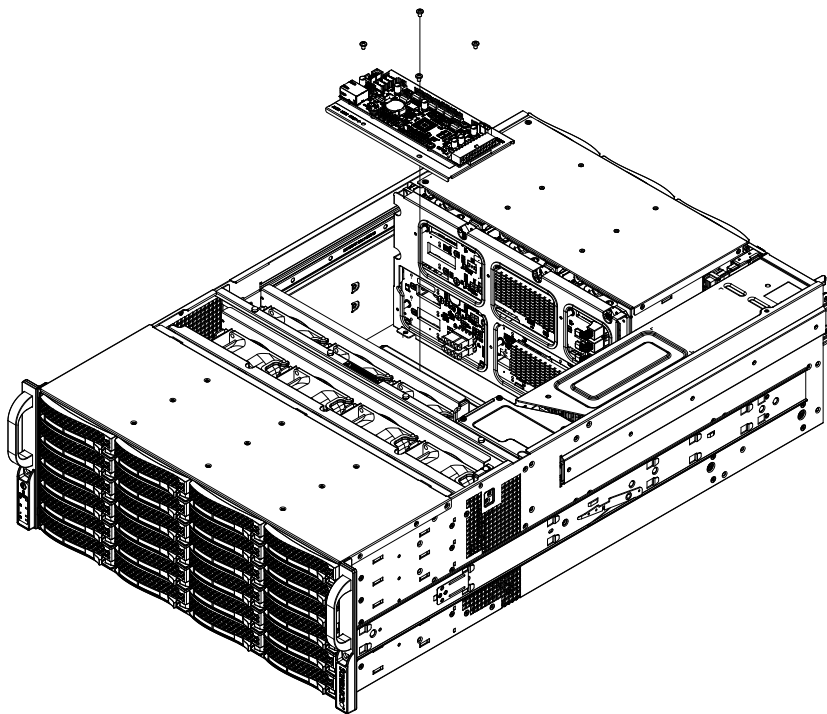

Figure 4-16. Control Board Location

4-9 Removing and Installing the Backplanes

The SC847 JBOD chassis comes equipped with a BPN-SAS3-846EL1/EL2 front backplane and a BPN-SAS3-827EL1/EL2 rear backplane. For detailed information and instructions on how to change the backplane settings, see Appendices C and D of this manual.

Removing the Front Backplane

1. Power down the system and remove the power cords from the rear of the power supplies. Remove the chassis cover.
2. Remove the two side screws securing the front backplane to the chassis.
3. Remove the four horizontal screws along the top of the front backplane.
4. Remove the five horizontal screws that go through the bottom of the backplane.

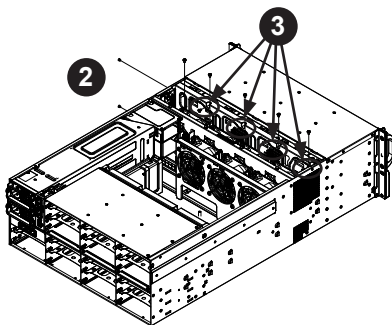

Figure 4-17. Removing the Screws Securing the Front Backplane

5. Lift the front backplane up and out of the chassis.

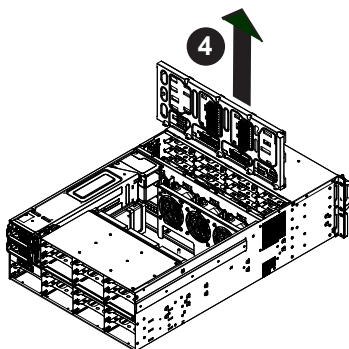

Figure 4-18. Removing the Front Backplane

Removing the Rear Backplane

1. Power down the system and remove the power cords from the rear of the power supplies. Remove the chassis cover as described in Section 4-2.
2. Remove the two side screws (one on each side of the chassis) which secure the rear tray to the chassis.
3. Pull the rear tray out of the back of the chassis as illustrated.

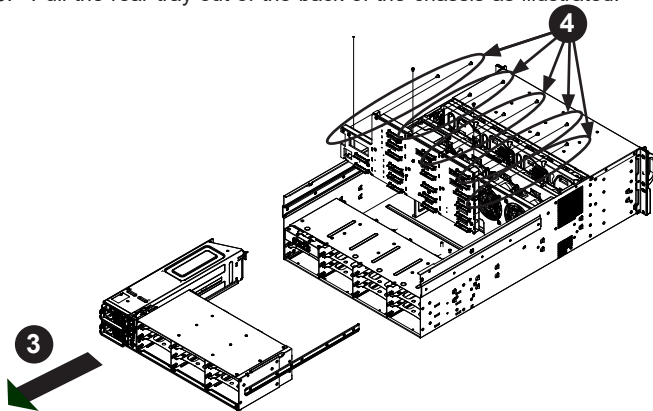

Figure 4-19. Removing the Screws Securing the Rear Backplane

4. Remove the nine horizontal screws going through the rear backplane.
5. Remove the three vertical screws securing the backplane to the chassis floor.
6. Lift the backplane up and out of the chassis.

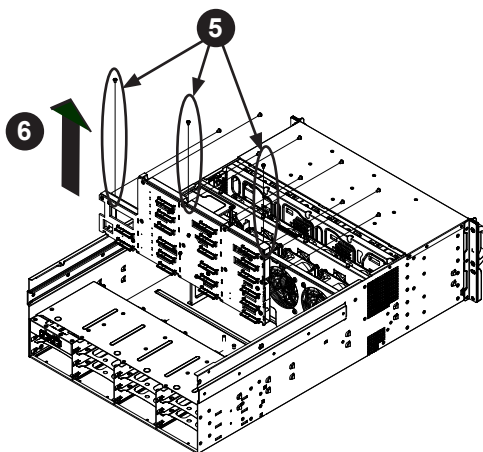

Figure 4-20. Removing the Three Screws Securing the Backplane

Installing the Front Backplane

1. Confirm that the power cords are still disconnected from the power supplies.
2. Place the front backplane in the chassis.

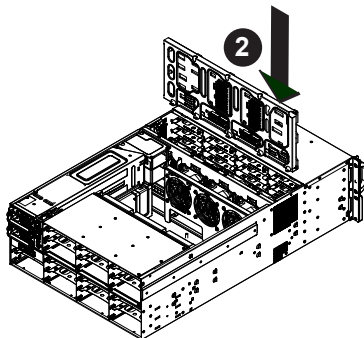

Figure 4-21. Installing the Front Backplane

3. Install the two side screws to secure the front backplane to the chassis.
4. Install the four horizontal screws along the top of the front backplane.
5. Install the five horizontal screws along the bottom of the front backplane.

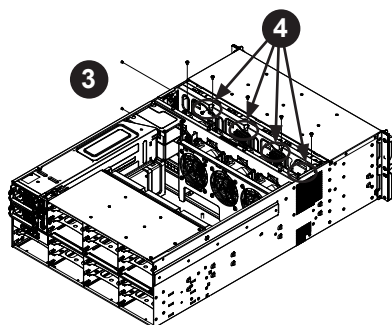

Figure 4-22. Installing the Screws Securing the Front Backplane

6. Plug the power cords into the rear of the power supply, replace the chassis cover and power up the system.

Installing the Rear Backplane

1. Confirm that the power cords are still disconnected from the power supplies.
2. Slide the rear tray out of the back of the chassis.

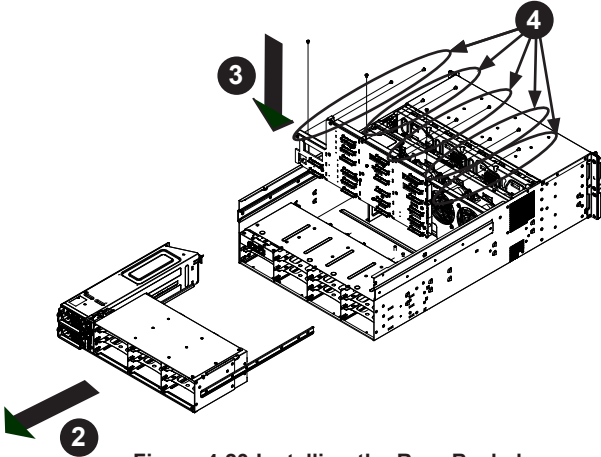

Figure 4-23 Installing the Rear Backplane

3. Place the rear backplane in the chassis and secure it with the three vertical screws along the top of the backplane.
4. Secure the backplane with nine horizontal screws through the backplane.
5. Plug the power cords into the rear of the power supply, replace the chassis cover and power up the system.

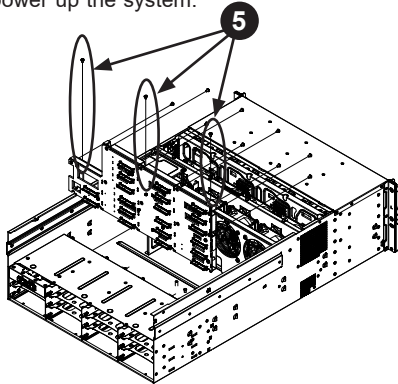

Figure 4-24. Installing the Screws Securing the Rear Backplane

Notes

Chapter 5

Rack Installation

This chapter provides instructions for preparing and mounting your chassis in a rack.

5-1 Unpacking the System

You should inspect the box the chassis was shipped in and note if it was damaged in any way. If the chassis itself shows damage, file a damage claim with the carrier who delivered it.

5-2 Preparing for Setup

Decide on a suitable location for the rack unit that will hold your chassis. It should be a clean, dust-free area that is well ventilated. Avoid areas where heat, electrical noise and electromagnetic fields are generated. A nearby grounded power outlet is required.

The box your chassis was shipped in should include two sets of rail assemblies, two rail mounting brackets and the mounting screws to mount the system into the rack. Please read this chapter in its entirety before beginning the installation procedure.

Choosing a Setup Location

- Leave at least 25 inches clearance in front of the rack to open the front door completely.
- Leave approximately 30 inches of clearance in the back of the rack to allow for sufficient airflow and access for servicing.
- It should be a restricted access location, such as a dedicated equipment room or a service closet.

5-3 Warnings and Precautions

Rack Precautions

- Ensure that the leveling jacks on the bottom of the rack are fully extended to the floor with the full weight of the rack resting on them.
- In single rack installations, stabilizers should be attached to the rack.
- In multiple rack installations, the racks should be coupled together.
- Always make sure that the rack is stable before extending a component from the rack.
- Only one chassis should be extended from the rack at a time. Extending two or more chassis simultaneously may cause the rack to become unstable.
- When initially installing the server to a rack, test that the rail locking tabs engage to prevent the server from being overextended. Have a rack lift in place as a precaution in case the test fails.
- In any instance of pulling the system from the rack, always use a rack lift and follow all associated safety precautions.

General Server Precautions

- Review the electrical and general safety precautions that came with the components you are adding to your chassis.
- Determine the placement of each component in the rack *before* you install the rails.
- Install the heaviest server components on the bottom of the rack first, and then work upward.
- Use a regulating uninterruptible power supply (UPS) to protect the server from power surges, voltage spikes and to keep your system operating in case of a power failure.
- Allow the hot-swappable hard drives and power supply modules to cool before touching them.
- Always keep the rack's front door and all panels and components on the servers closed when not servicing to maintain proper cooling.

Rack Mounting Considerations

Ambient Operating Temperature

If installed in a closed or multi-unit rack assembly, the ambient operating temperature of the rack environment may be greater than the ambient temperature of the room. Therefore, consideration should be given to installing the equipment in an environment compatible with the manufacturer's maximum rated ambient temperature (TMRA).

Sufficient Airflow

Equipment should be mounted into a rack so that the amount of airflow required for safe operation is not compromised.

Circuit Overloading

Consideration should be given to the connection of the equipment to the power supply circuitry and the effect that any possible overloading of circuits might have on overcurrent protection and power supply wiring. Appropriate consideration of equipment nameplate ratings should be used when addressing this concern.

Reliable Ground

A reliable ground must be maintained at all times. To ensure this, the rack itself should be grounded. Particular attention should be given to power supply connections other than the direct connections to the branch circuit (i.e. the use of power strips, etc.).



Warning: To prevent bodily injury when mounting or servicing this unit in a rack, you must take special precautions to ensure that the system remains stable. The following guidelines are provided to ensure your safety:

- This unit should be mounted at the bottom of the rack if it is the only unit in the rack.
- When mounting this unit in a partially filled rack, load the rack from the bottom to the top with the heaviest component at the bottom of the rack.
- If the rack is provided with stabilizing devices, install the stabilizers before mounting or servicing the unit in the rack.
- Slide rail mounted equipment is not to be used as a shelf or a work space.

5-4 Installing the Rails

There are a variety of rack units on the market, and some may require a slightly different assembly procedure. The following is a basic guideline for installing the system into a rack with the provided rack rails. Also refer to the installation instructions that came with the specific rack you are using.

This rail set fits a rack between 26.5" and 36.4" deep. Do not use a two post "telco" type rack.

Identifying the Rails

The chassis package includes two rail assemblies. Each assembly consists of three sections: An inner rail that secures directly to the chassis, an outer rail that secures to the rack, and a middle rail which extends from the outer rail. These assemblies are specifically designed for the left and right side of the chassis and labeled.

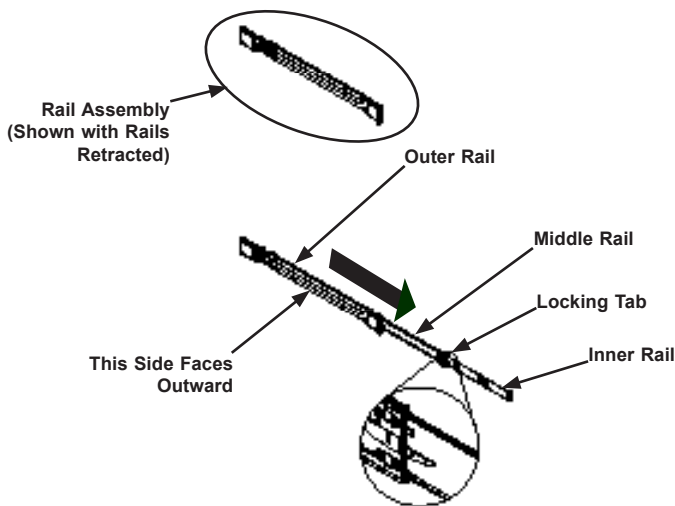

Figure 5-1. Identifying the Outer Rail, Middle Ra. Rail
(Left Rail Assembly Shown)

Note: Both front chassis rails and the rack rails have a locking tab, which serves two functions. First, it locks the server into place when installed and pushed fully into the rack (its normal operating position). In addition, these tabs lock the server in place when fully extended from the rack. This prevents the server from coming completely out of the rack when pulled out for servicing.

Releasing the Inner Rail

Each inner rail has a locking latch. This latch prevents the server from coming completely out of the rack when the chassis is pulled out for servicing.

To mount the rail onto the chassis, first release the inner rail from the outer rails.

1. Pull the inner rail out of the outer rail until it is fully extended as illustrated below.
2. Press the locking tab down to release the inner rail.
3. Pull the inner rail all the way out.

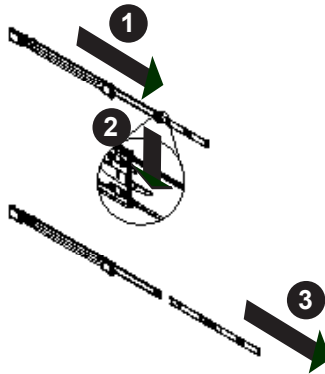

Figure 5-2. Extending and Releasing the Inner Rail

Installing the Inner Rails on the Chassis

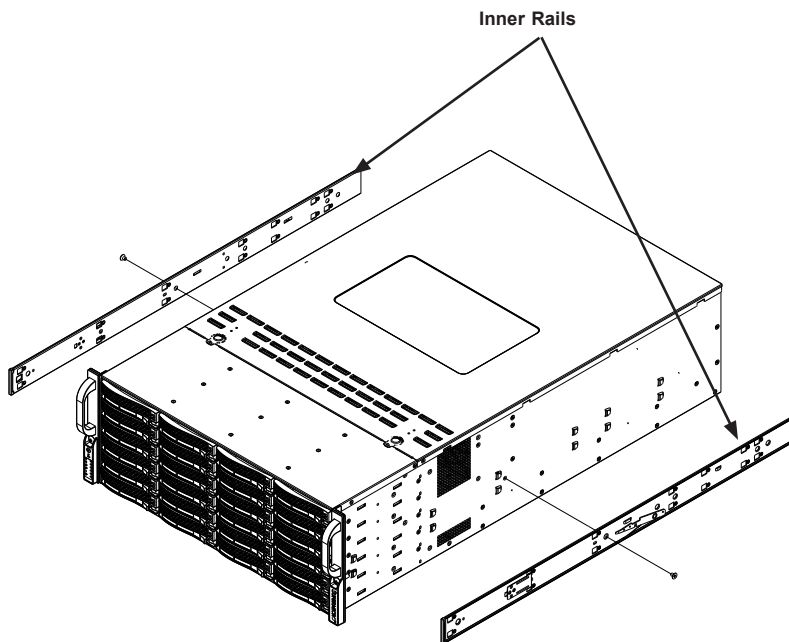
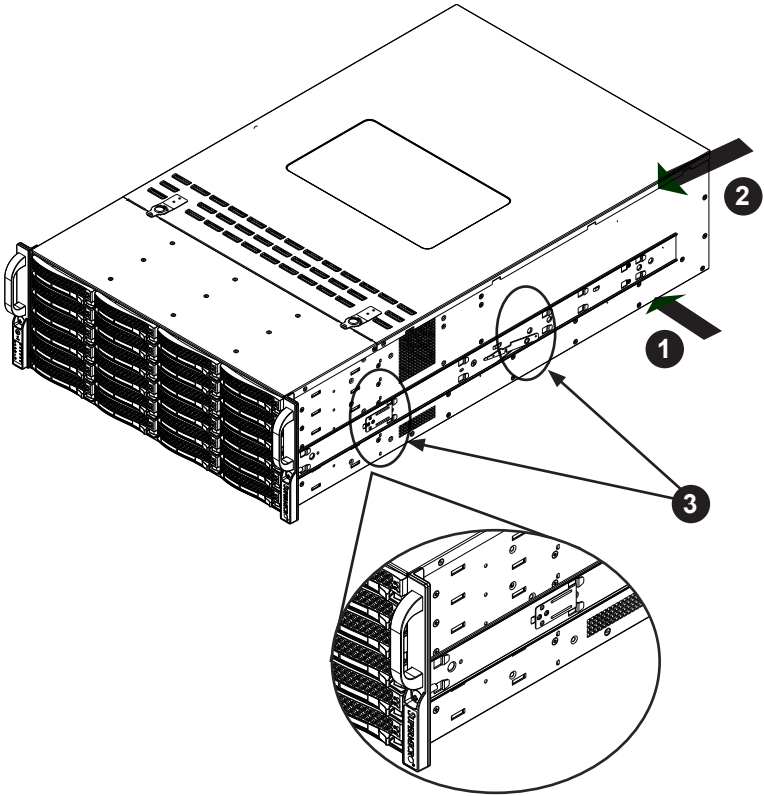

Figure 5-3. Installing the Inner Rails

Installing the Inner Rails

1. Identify the left and right side inner rails. Place the correct inner rail on the side of the chassis, aligning the hooks of the chassis with the inner rail holes. Make sure the rail faces "outward" so that it will fit with the rack's mounting bracket.
2. Slide the rail toward the front of the chassis to hook the inner rail onto the side of the chassis.
3. If desired, secure the rail with two flat head M4 x 4mm screws as illustrated.
4. Repeat for the other inner rail.



Warning: Do not pick up the server by the front handles. They are designed to pull the system from a rack only.

Installing the Outer Rails onto the Rack

Installing the Outer Rails

1. Press upward on the locking tab at the rear end of the middle rail.
2. Push the middle rail back into the outer rail.
3. Hang the hooks on the front of the outer rail onto the square holes on the front of the rack. If desired, use screws to secure the outer rails to the rack.
4. Pull out the rear of the outer rail, adjusting the length until it just fits within the posts of the rack.
5. Hang the hooks of the rear section of the outer rail onto the square holes on the rear of the rack. Take care that the proper holes are used so the rails are level. If desired, use screws to secure the rear of the outer rail to the rear of the rack.
6. Repeat for the other outer rail.

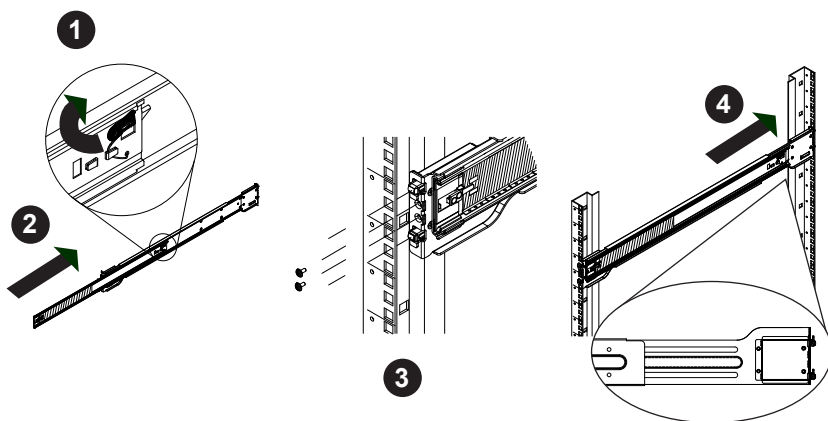

Figure 5-4. Extending and Mounting the Outer Rails



Stability hazard. The rack stabilizing mechanism must be in place, or the rack must be bolted to the floor before you slide the unit out for servicing. Failure to stabilize the rack can cause the rack to tip over.

Do not use a two post "telco" type rack.

Installing the Chassis into a Rack

Installing the Chassis into a Rack:

1. Align the chassis rails (A) with the front of the rack rails (B).
2. Slide the chassis rails into the rack rails, keeping the pressure even on both both sides. You may have to depress the locking tabs while inserting. When the server has been pushed completely into the rack, the locking tabs should "click" into the locked position.
3. If screws are used, tighten the screws on the front and rear of the outer rails.
4. (Optional) Insert and tighten the thumbscrews that hold the front of the server to the rack.

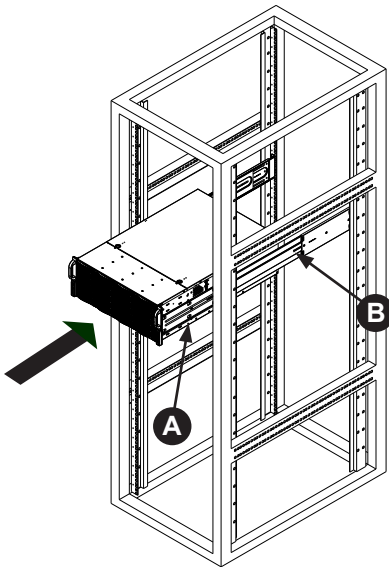

Figure 5-5. Installing the Chassis into a Rack

Note: Figures are for illustrative purposes only. Always install servers into racks from the bottom up.

Removing the Chassis from the Rack

Caution! It is dangerous for a single person to off-load the heavy chassis from the rack without assistance. Be sure to have sufficient assistance supporting the chassis when removing it from the rack. Use a lift.

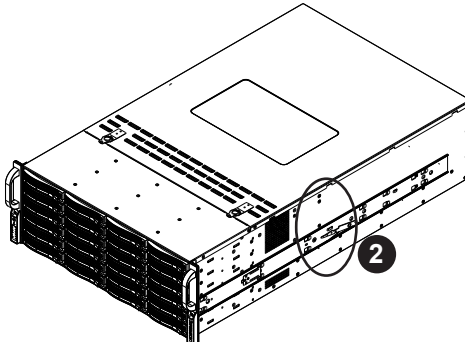

Figure 5-6. Removing the Chassis From the Rack

Removing the Chassis from the Rack

1. Pull the chassis forward out the front of the rack until it stops.
2. Press the release latches on each of the inner rails downward simultaneously and move the chassis forward in the rack.

Chapter 6

CSE-PTJBOD-CB3 Control Board

6-1 Overview

The CSE-PTJBOD-CB3 model JBOD control board allows the user to remotely control and monitor the chassis resources using the BMC, such as powering on or off, controlling fan speeds and reading temperature data from the backplane. It has been designed to utilize the most up-to-date technology available, providing your system with reliable, high-quality performance.

This manual reflects the revision 1.02 JBOD control board, the most current release available at the time of publication. Refer to the Supermicro web site at www.supermicro.com for the latest updates, compatible parts and supported configurations.

6-2 Safety Guidelines

ESD Safety Guidelines

Electrostatic Discharge (ESD) can damage electronic components. To prevent damage to your system, it is important to handle it very carefully. The following measures are generally sufficient to protect your equipment from ESD.

- Use a grounded wrist strap designed to prevent static discharge.
- Touch a grounded metal object before removing a component from the antistatic bag.
- Handle the control board by its edges only; do not touch its components, peripheral chips, memory modules or gold contacts.
- When handling chips or modules, avoid touching their pins.
- Put the control board and peripherals back into their antistatic bags when not in use.

General Safety Guidelines

- Always disconnect power cables before installing or removing any components from the computer, including the control board.
- Disconnect the power cable before installing or removing any cables from the control board.
- Make sure that the control board is securely and properly installed in the chassis to prevent damage to the system due to power shortage.

6-3 Components, Connectors, Jumpers and LEDs

Component and Connector Locations

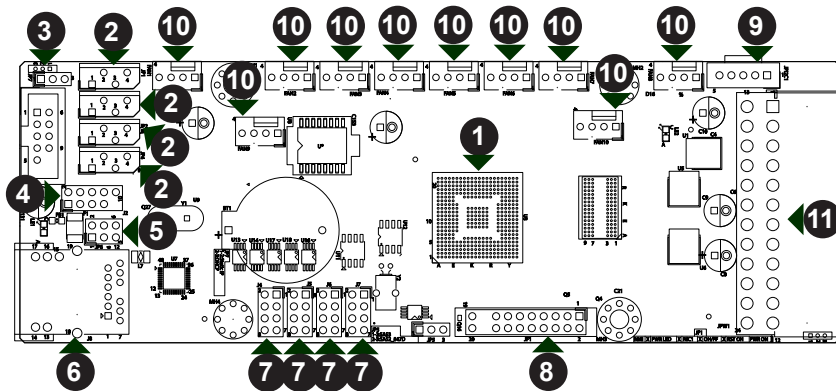

Figure 6-1. Components and Connectors on the CSE-PTJBOD-CB3

Components and Connectors

- | | |
|--|--|
| 1. BMC Chip | 5. BMC LAN LED Header: JP6 |
| 2. SAS2/SAS3 I ² C Connectors JP1-JP4 | 6. BMC LAN Connector: J8 |
| 3. Manufacturing Test Connector: J3 | 7. (SC847D only) SAS2 I ² C Connectors: J4 - J7 |
| 4. Manufacturer's USB Test Connector: FB1 | 8. Control Panel Connector: JF1 |
| 5. BMC LAN LED Header: JP6 | 9. PMBus Connector: JPI ² C1 |
| | 10. Fan Connectors: FAN1 - FAN10 |
| | 11. ATX Power Connector: JPW1 |

Component and Connector Definitions

1. BMC Chip

The Baseboard Management Controller (BMC) chip monitors the physical state of a system and provides communication with the system administrator through an independent connection.

2. I²C Connectors

These connectors (JP1-JP4) accept cables for up to four SAS2/SAS3 backplanes that carry management data between the the backplane and the control board.

3 and 4. Manufacturing Test Connectors

Connectors J3 and FB1 are for Supermicro manufacturing use only.

5. BMC LAN LED Header

This connector is designated JP6 and is used to connect to the LED indicators on the chassis using cable CBL-NTWK-0584 or CBL-NTWK-0587.

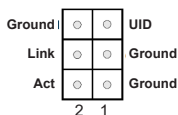

6. BMC LAN Connector

The baseboard management controller (BMC) LAN connector is designated J8 and supports connectivity with a local network using cable CBL-NTWK-0584 or CBL-NTWK-0587.

7. SC847D SAS2 I²C Connectors

(Used for SC847D only) The backplane connectors, designated J4-J7, accept internal cables to connect to up to four SC847D expanders.

8. Control Panel Connector

This connector is designated JF1 and connects to the control panel on the chassis. See Chapter 3 for additional control panel information.

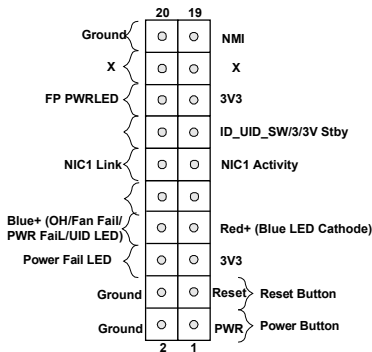

9. PMBus Connector

This connector is designated JPI2C1 and connects the power distributor to the Power Management Bus (PMBus).

10. Fan Connectors

The fan connectors supply power to the fans and are designated FAN1-FAN10.

11. ATX Power Connector

The ATX power connector is designated JPW1.

Jumpers and LED Indicators

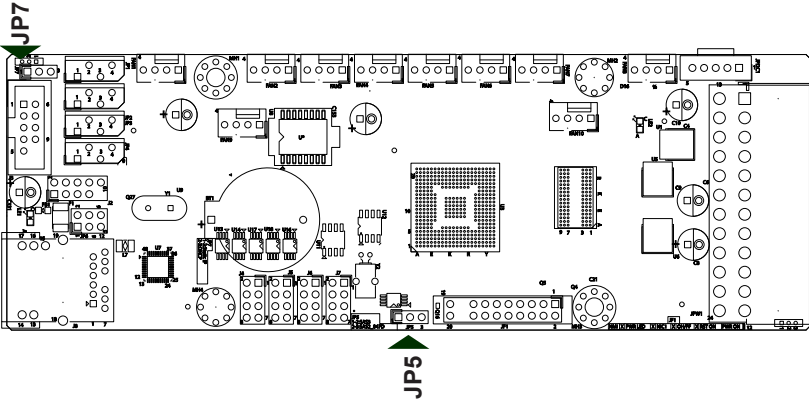

Figure 6-2. Jumpers

SAS2/SAS3 Jumpers	
Jumper	Description
JP7	Pins 1-2: Obsolete, do not use Pins 2-3: User mode (static/DHCP, default)
JP5	Pins 1-2: SAS3 enabled Pins 2-3: SAS2 enabled and SC847D

To enable SAS2 or SAS3 functionality on the I²C connectors, set the JP5 jumper as noted.

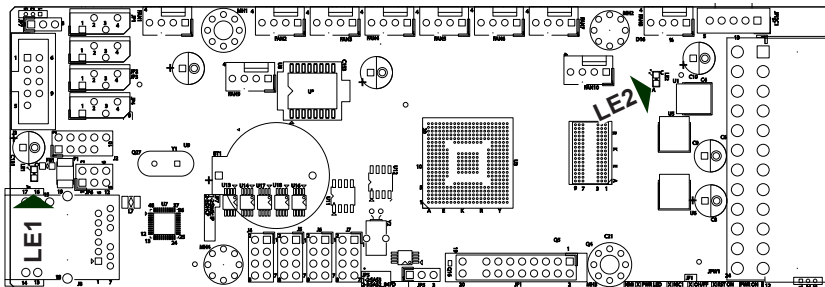

Figure 6-3. LED Indicators

LED Indicators	
LED	Description
LE1	Heartbeat LED: A blinking LED indicates BMC activity
LE2	Power LED: DC power indicator

6-4 I²C Cabling to the Backplane

This JBOD storage enclosure is pre-configured with the internal cables connected. Use this section for reference if a cable becomes disconnected during maintenance. Ensure that the JP5 jumper on the JBOD control board is set according to the table in the section, *Jumpers and LED Indicators*.

When enabling SAS2/SAS3 functionality, connect the I²C connectors on the JBOD control board (Figure CB3-1) to the proper connector on the backplane. Refer to the table below and the backplane documentation to determine the correct connector.

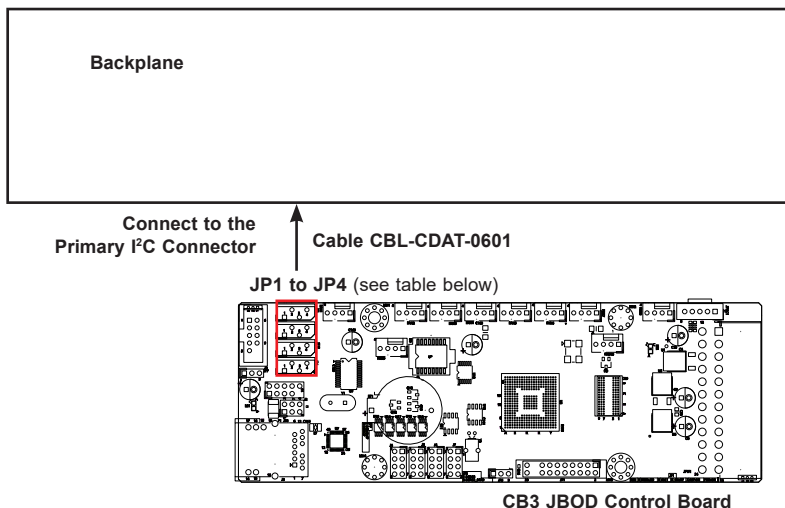

Figure 6-4. SAS I²C Cabling (except SC847D)

Connections for SC847 JBOD Chassis

Specific I²C connectors (JP1-JP4) on the JBOD control board are connected to the backplane.

I ² C Cable Connections for SC847 JBOD	
Control Board	BPN-SAS3-216EL Backplane
JP1	SMB connector

6-5 JBOD Power Up/Power Down Sequences

There are several procedures to turn on or off the system with the CB3 JBOD control board.

Power Up

First Use or Power Cord Plug-In

1. Plug the power cords into the rear of the power supplies.
2. Wait until blue Information LED starts to blink.
3. Press the power button once. The JBOD control board initiates the power up sequence in three seconds.

After Normal Shutdown by BMC or Power Button

Press the power button once. The JBOD control board will initiate the power up sequence in three seconds.

After a Power Loss

The system will power up automatically approximately 45 seconds after the power returns.

Power Down

1. Hold down the power button. The blue Information LED will begin blinking. Continue to hold the power button.
2. Release power button after blue LED stops blinking and goes dark.
3. The shutdown sequence will begin and shut down the system within ten seconds

6-6 BMC

The control board provides remote access, monitoring and management through the baseboard management controller (BMC) and other management controllers distributed among different system modules. There are several BIOS settings that are related to BMC. For general documentation and information on BMC, visit our website at:

www.supernmicro.com/en/solutions/management-software/bmc-resources

BMC ADMIN User Password

For security, each system is assigned a unique default BMC password for the ADMIN user. This can be found on a sticker on the chassis and a sticker on the control board. The sticker also displays the BMC MAC address.



Figure 6-5. BMC Password Label

IP Address

The default IP address configuration mode is Dynamic Host and Configuration Protocol (DHCP). When connected to the network, you can find the IP address assigned to this system from the DHCP server. (See below for an additional method to identify the assigned IP address.) This allows you to log in to the BMC.

Note: The IP configuration mode can be reset to Static IP mode for troubleshooting. Press and hold the UID/reset button on the front Control panel for 6-8 seconds to change to static IP mode with the default IP address as shown below. Return the IP configuration mode back to DHCP using the BMC.

Simple setup configuration:

BMC default IP: 192.168.1.99

User name: ADMIN

Password: Unique password, as noted on sticker (details above)

Finding BMC IP Address Using SAS In-band (Linux)

An alternate method of finding the IP address:

1. Identify the JBOD enclosure name, for example /dev/sg4.
2. Use the **vpd** command to view the IP address.

```
[root@hdmaster user]# sg_vpd -p 0x85 /dev/sg4
Management network addresses VPD page:
    Target device that contains addressed lu, Service type: unspecified
    172.31.40.150
[root@hdmaster user]#
```

Notes

Appendix A

SC847 JBOD Power Supply Specifications

This appendix lists power supply specifications for your chassis system.

1200W (Redundant)	
Supermicro Part #	PWS-1K23A-1R with PDB
AC Input	100-240 V, 4.5-11 Amp, 50-60 Hz
DC Output +12V	1000W (100-127Vac) 83A 1200W (200-240V) 100A 1200W (200-240Vdc) 100A
+5V standby	4 Amp



Appendix B

Compliance

Regulatory Compliance

FCC, ICES, CE, UKCA, VCCI, RCM, NRTL, CB

Applied Directives, Standards

EMC/EMI: 2014/30/EU (EMC Directive)
Electromagnetic Compatibility Regulations 2016
FCC Part 15 Subpart B
ICES-003
VCCI-CISPR 32
AS/NZS CISPR 32
BS/EN55032
BS/EN55035
CISPR 32
CISPR 24/CISPR 35
BS/EN 61000-3-2
BS/EN 61000-3-3
BS/EN 61000-4-2
BS/EN 61000-4-3
BS/EN 61000-4-4
BS/EN 61000-4-5
BS/EN 61000-4-6
BS/EN 61000-4-8
BS/EN 61000-4-11

Environment:
2011/65/EU (RoHS Directive)
EC 1907/2006 (REACH)
2012/19/EU (WEEE Directive)
California Proposition 65

Product Safety: 2014/35/EU (LVD Directive)
UL/CSA 62368-1 (USA and Canada)
Electrical Equipment (Safety) Regulations 2016
IEC/BS/EN 62368-1

Perchlorate Warning

California Best Management Practices Regulations for Perchlorate Materials: This Perchlorate warning applies only to products containing CR (Manganese Dioxide) Lithium coin cells. "Perchlorate Material-special handling may apply. See www.dtsc.ca.gov/hazardouswaste/perchlorate"

Disclaimer (cont.)

The products sold by Supermicro are not intended for and will not be used in life support systems, medical equipment, nuclear facilities or systems, aircraft, aircraft devices, aircraft/emergency communication devices or other critical systems whose failure to perform be reasonably expected to result in significant injury or loss of life or catastrophic property damage. Accordingly, Supermicro disclaims any and all liability, and should buyer use or sell such products for use in such ultra-hazardous applications, it does so entirely at its own risk. Furthermore, buyer agrees to fully indemnify, defend and hold Supermicro harmless for and against any and all claims, demands, actions, litigation, and proceedings of any kind arising out of or related to such ultra-hazardous use or sale.

Appendix C

BPN-SAS3-846EL Backplane Specifications

To avoid personal injury and property damage, carefully follow all the safety steps listed below when accessing your system or handling the components.

C-1 ESD Safety Guidelines

Electrostatic Discharge (ESD) can damage electronic components. To prevent damage to your system, it is important to handle it very carefully. The following measures are generally sufficient to protect your equipment from ESD.

- Use a grounded wrist strap designed to prevent static discharge.
- Touch a grounded metal object before removing a component from the antistatic bag.
- Handle the backplane by its edges only; do not touch its components, peripheral chips, memory modules or gold contacts.
- When handling chips or modules, avoid touching their pins.
- Put the card and peripherals back into their antistatic bags when not in use.

C-2 General Safety Guidelines

- Always disconnect power cables before installing or removing any components from the computer, including the BPN-SAS3-846EL series backplane.
- Make sure that the backplane is properly and securely on the motherboard to prevent damage to the system due to power outages.

C-3 An Important Note to Users

All images and layouts shown in this user's guide are based upon the latest backplane revision available at the time of publishing. The card you have received may or may not look exactly the same as the graphics shown in this manual.

C-4 Introduction to the BPN-SAS3-846EL Backplane

The BPN-SAS3-846EL backplane has been designed to utilize the most up-to-date technology available, providing your system with reliable, high-quality performance.

This manual reflects BPN-SAS3-846EL Revision 1.01, the most current release available at the time of publication. Always refer to the Supermicro Web site at www.supermicro.com for the latest updates, compatible parts and supported configurations.

C-5 Overview of the BPN-SAS3-846EL1/EL2 Backplanes

The BPN-SAS3-846EL1 and BPN-SAS3-846EL2 model backplanes are identical, except that the BPN-SAS3-846EL2 backplane has duplicate secondary components which are not found on the BPN-SAS3-846EL1. The BPN-SAS3-846EL2 is divided into a two sections, with the primary components on the right side of the board and the secondary components on the left. SAS3 backplanes are not compatible with legacy SAS (3 Gbps), SATA (1.5 Gbps) backplanes or lower.

C-6 Front Connectors

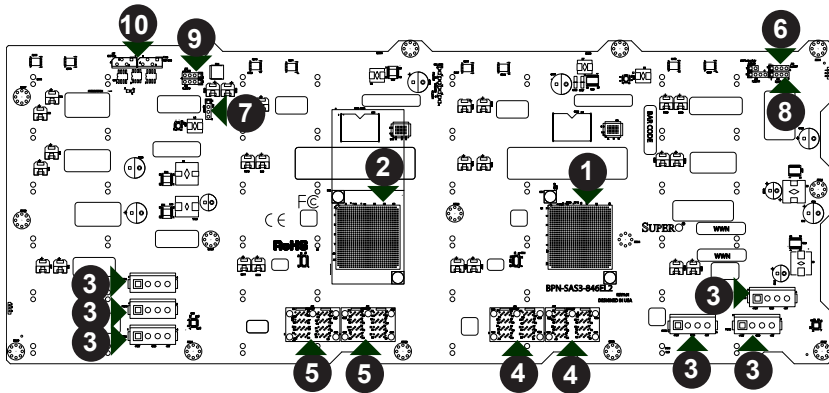

Figure C-1: BPN-SAS3-846EL1/EL2 Connectors and Components

1. Primary Expander Chip.
2. Secondary Expander Chip (not present on EL1 single port backplanes).
3. Backplane Power Connectors: PWR1 through PWR6.
4. Primary SAS Ports: J49, J50.
5. Secondary SAS Ports: J51, J52. (not present on EL1 single port backplanes).
6. Primary UART Connector: PRI-
UART (J30) for manufacturer's
use only.
7. Secondary UART Connector:
SEC-
UART(J24) for manufacturer's
use only, not present on
EL1 backplanes.
8. Primary SDB Connector: PRI-
SDB (J31), for manufacturer's
use only.
9. Secondary SDB Connector: SEC-
SDB (J29), for manufacturer's
use only, not present on EL1
backplanes.
10. I²C Connector, EXP I2C0 (J48).

C-7 Front Connector and Pin Definitions

1. - 2. Primary and Secondary Expander Chips

The primary and secondary expander chips allow the backplane to support dual port, cascading, and failover configurations.

3. Backplane Power Connectors

The 4-pin connectors, designated PWR1 - PWR6 provide power to the backplane. See the table on the right for pin definitions.

Backplane Main Power 4-Pin Connector	
Pin#	Definition
1	+12V
2 and 3	Ground
4	+5V

4. - 5. Primary and Secondary SAS Ports

The primary SAS connectors are designated J49 and J50. The secondary SAS Ports are designated J51 through J52 and are not present on EL1 single port backplanes.

6. - 7. Primary and Secondary UART Connectors

The primary UART connector is designated PRI-UART and J30. The secondary UART connector is designated SEC-UART and J24 and is not present on BPN-SAS3-846EL1. UART connectors are used for manufacturer's diagnostic purposes only.

8. - 9. SDB Connectors

The Primary SDB connector is designated PRI-SDB and J31. The secondary SDB connector is designated SEC-SDB and J29. (Not present on BPN-SAS3-846EL1 backplanes) These are debug connectors used for the manufacturer's diagnostic purposes only.

10. I²C Connectors

The I²C connector. is designated EXP I2C0.

C-8 Front Jumper Location and Settings

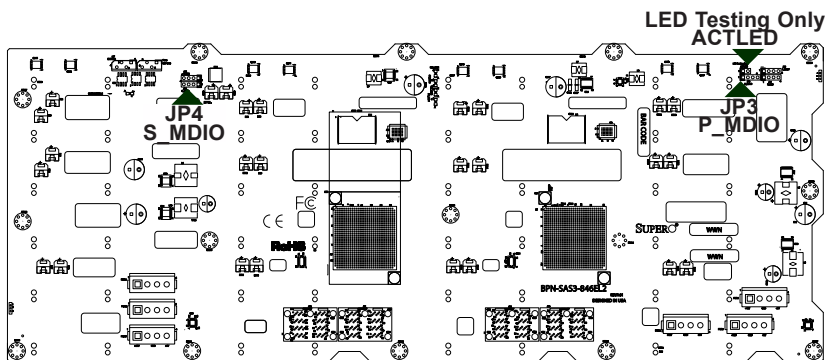
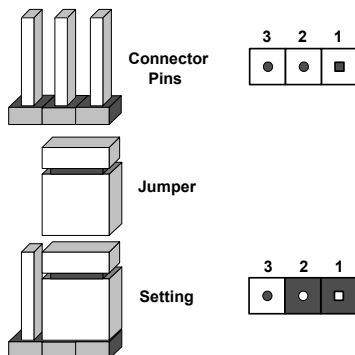

Figure C-2: Front Jumpers

Explanation of Jumpers

To modify the operation of the backplane, jumpers can be used to choose between optional settings. Jumpers create shorts between two pins to change the function of the connector. Pin 1 is identified with a square solder pad on the printed circuit board. Note: On two pin jumpers, "Closed" means the jumper is on and "Open" means the jumper is off the pins.



General Jumper Settings		
Jumper	Jumper Settings	Note
LED Testing Only ACTLED	Open: Disabled (Default) Closed: Enabled	Activity LED test.
JP3 P_MDIO	Open: Disabled (Default) Closed: Enabled	Primary management data in/out. For manufacturer's use only
JP4 S-MDIO	Open: Disabled (Default) Closed: Enabled	Secondary management data in/out. For manufacturer's use only

C-9 Front LED Indicators

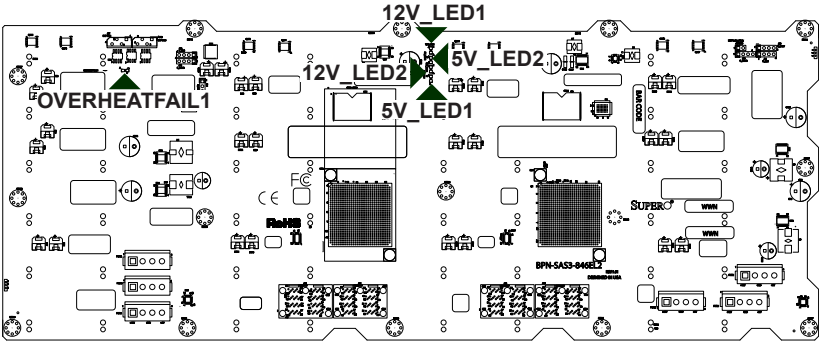

Figure C-3: Front LEDs

Backplane LEDs			
LED	Normal State	Abnormal State	Specification
12V_LED1	On	Off	12V power status
12V_LED2	Blinking	Steady on, or off	Primary expander heartbeat indicator
5V_LED1	On	Off	5V power status
5V_LED2	Blinking	Steady on, or off	Secondary expander heartbeat indicator (not present on BPN-SAS3-846EL1 backplanes).
OVERHEATFAIL1	Off	On	System overheat/failure LED

C-10 Rear Connectors and LED Indicators

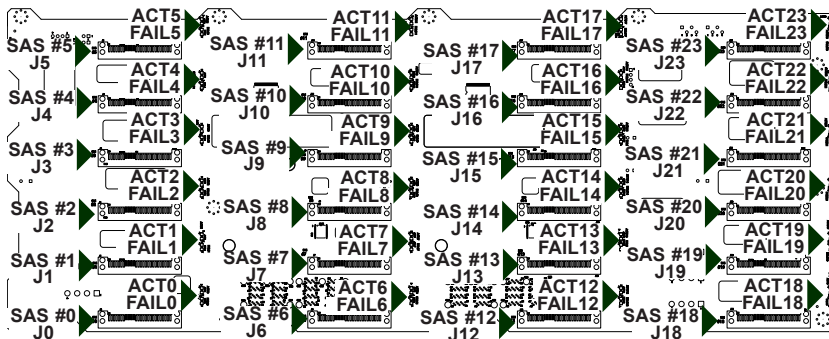

Figure C-4: Rear Connectors and LEDs

Rear SAS Connectors			
Rear Connector	SAS Drive Number	Rear Connector	SAS Drive Number
SAS #0	SAS HDD #0	SAS #12	SAS HDD #12
SAS #1	SAS HDD #1	SAS #13	SAS HDD #13
SAS #2	SAS HDD #2	SAS #14	SAS HDD #14
SAS #3	SAS HDD #3	SAS #15	SAS HDD #15
SAS #4	SAS HDD #4	SAS #16	SAS HDD #16
SAS #5	SAS HDD #5	SAS #17	SAS HDD #17
SAS #6	SAS HDD #6	SAS #18	SAS HDD #18
SAS #7	SAS HDD #7	SAS #19	SAS HDD #19
SAS #8	SAS HDD #8	SAS #20	SAS HDD #20
SAS #9	SAS HDD #9	SAS #21	SAS HDD #21
SAS #10	SAS HDD #10	SAS #22	SAS HDD #22
SAS #11	SAS HDD #11	SAS #23	SAS HDD #23

Rear LED Indicators		
Rear LED	Hard Drive Activity	Failure LED
SAS #0	ACT0	FAIL0
SAS #1	ACT1	FAIL1
SAS #2	ACT 2	FAIL2
SAS #3	ACT3	FAIL3
SAS #4	ACT4	FAIL4
SAS #5	ACT5	FAIL5
SAS #6	ACT6	FAIL6
SAS #7	ACT7	FAIL7
SAS #8	ACT8	FAIL8
SAS #9	ACT 9	FAIL9
SAS #10	ACT10	FAIL10
SAS #11	ACT11	FAIL11
SAS #12	ACT12	FAIL12
SAS #13	ACT13	FAIL13
SAS #14	ACT14	FAIL14
SAS #15	ACT15	FAIL15
SAS #16	ACT16	FAIL16
SAS #17	ACT17	FAIL17
SAS #18	ACT18	FAIL18
SAS #19	ACT19	FAIL19
SAS #20	ACT20	FAIL20
SAS #21	ACT21	FAIL21
SAS #22	ACT22	FAIL22
SAS #23	ACT23	FAIL23

C-11 Single and Dual Port Expanders

SAS primary connectors J49 to J50 and secondary connectors J51 to J52 are bidirectional and can be treated as input or output.

Single Ports

BPN-SAS3-846EL1 backplanes have a single port expander that accesses all of the drives and supports cascading.

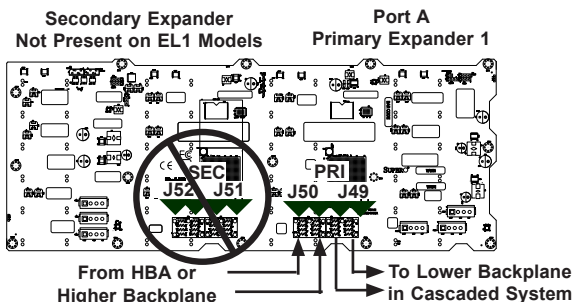

Figure E-5: BPN-SAS3-846EL1 Single Port Configuration

Dual Ports

BPN-SAS3-846EL2 model backplanes have dual-port expanders that access all of the hard drives. These dual-port expanders support cascading, failover, and recovery.

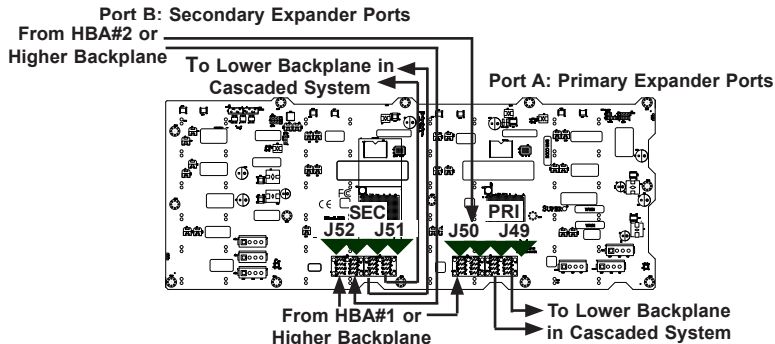

Figure C-6: BPN-SAS3-846EL2 Dual Port Configuration

C-12 Failover

The BPN-SAS3-846EL2 model backplane has two expanders which enable effective failover and recovery.

Single Host Bus Adapter

In a single host bus configuration, the backplane connects to one host bus adapter.

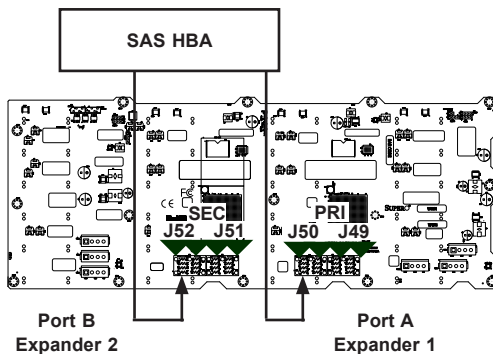

Figure C-7: Single HBA

Single Host Bus Adapter Failover

If the expander or data path in Port A fails, the system automatically switches to Port B with application software or failover support.

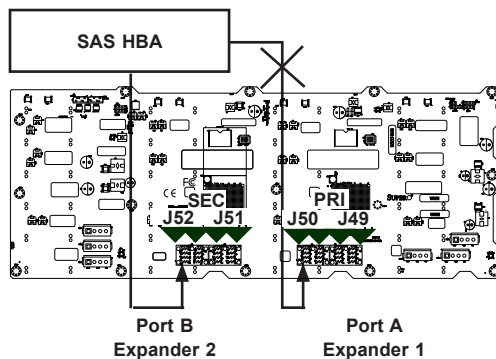

Figure C-8: Single HBA Failover

C-13 Failover with RAID Cards and Multiple HBAs

The BPN-SAS3-846EL backplane may be configured for failover with multiple HBAs using either RAID controllers or HBAs to achieve failover protection.

RAID Controllers: If RAID controllers are used, then the failover is accomplished through port failover on the same RAID card.

HBAs: If multiple HBAs are used to achieve failover protection and load balancing, **Linux MPIO software must be installed and correctly configured to perform the load balancing and failover tasks.**

Dual Host Bus Adapter

In a dual host bus configuration, the backplane connects to two HBA's.

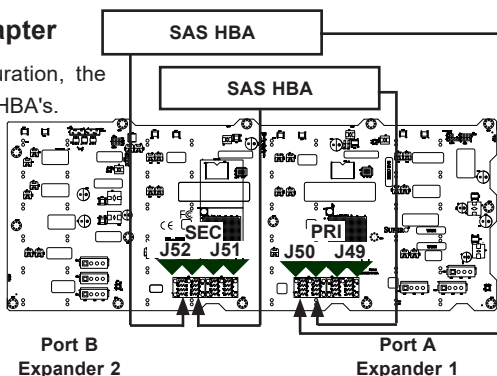

Figure C-9: Dual HBA

Dual Host Bus Adapter Failover

If the expander or data path in Port A fails, the system automatically switches to Port B. This maintains a full connection to all drives.

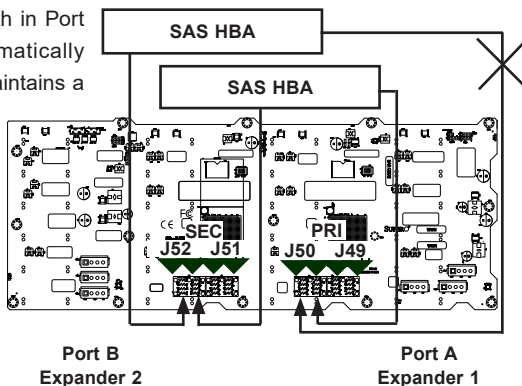

Figure C-10: Dual HBA Failover

IMPORTANT: For RAID controllers, redundancy is achieved through port failover. For multiple HBAs MPIO software is required to achieve failover protection.

C-14 Connecting HBAs to the Backplane

Connecting an Internal HBA to the Backplane

The following section lists the most common cables used to connect the HBA to the backplane.

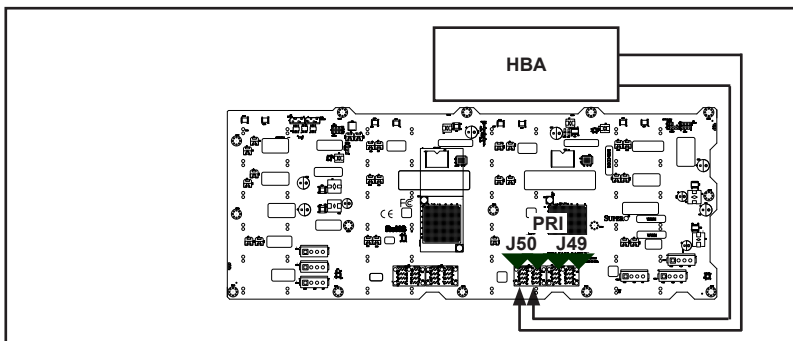

Figure C-11: Single Internal Host Bus Adapter

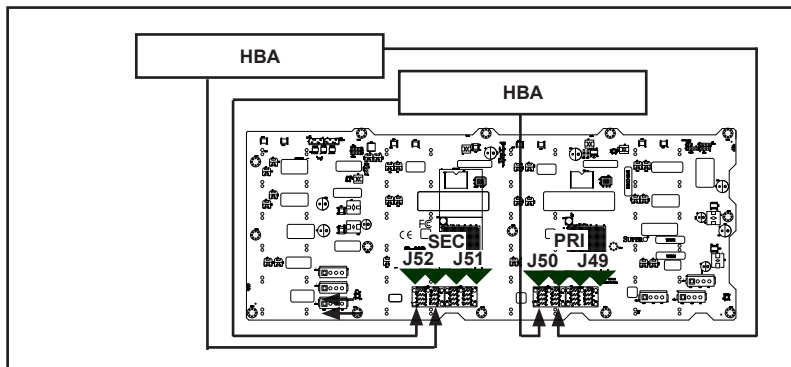

Figure C-12: Dual Internal Host Bus Adapter

Supported Internal HBA Cables

Use the following cables to create connections between the internal HBA and BPN-SAS3-846EL model backplane. The cables required depend upon the HBA connector.

IMPORTANT: See Section 3-3 of this manual, *Failover with RAID Cards and Multiple HBAs* for important information on supported configurations.

Cable Name: Internal iPass (Mini-SAS) to HD (Mini-SAS)

Part #: CBL-SAST-0508-01 **Length:** 50 cm (19 inches)

Part #: CBL-SAST-0507-01 **Length:** 80 cm (31 inches)

Description: This cable has an iPass (SFF-8087/Mini-SAS) connector (36-pin) at one end and a Mini-SAS HD (SFF-8643) connector at the other end. It connects from the SAS2 HBA to the BPN-SAS3-846EL model backplane.

Cable name: Internal HD (Mini-SAS) to HD (Mini-SAS)

Part #: CBL-SAST-0568 **Length:** 35 cm (13 inches)

Part #: CBL-SAST-0593-01 **Length:** 60 cm (23 inches)

Part #: CBL-SAST-0531 **Length:** 80 cm (31 inches)

Description: This cable has a Mini-SAS HD (SFF-8643) connector at both ends. It connects from the SAS3 HBA to the BPN-SAS3-846EL model backplane.

Connecting an External HBA to the Backplane

This backplane supports external host bus adapters. In this configuration, the HBA and the backplane are in different physical chassis. This allows a JBOD (Just a Bunch Of Drives) configuration from an existing system.

Single External Host Bus Adapter

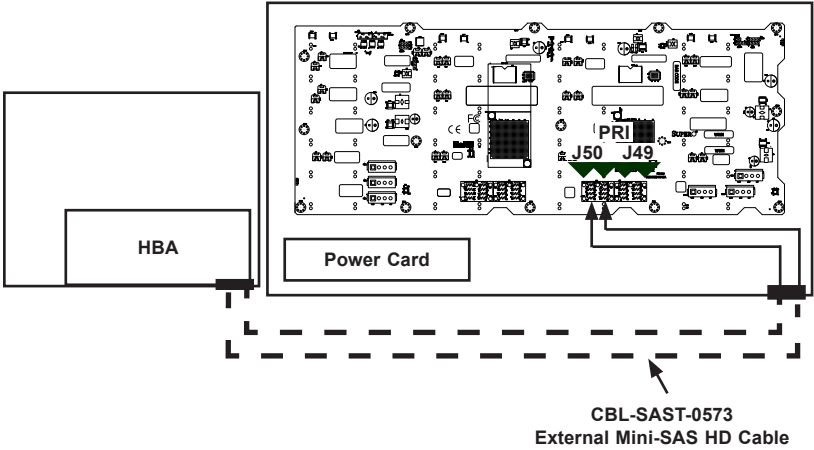

Figure C-9: Single External Host Adapter

Dual External Host Bus Adapter

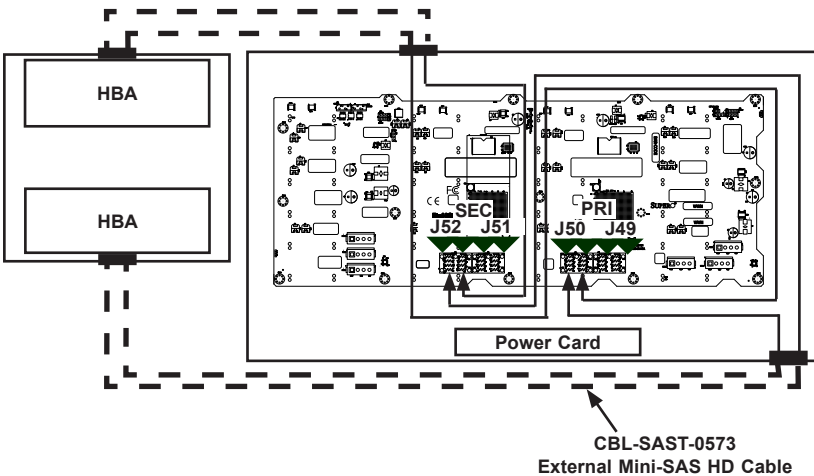

Figure C-13: Dual External Host Bus Adapter

IMPORTANT: See Section 3-3 of this manual, *Failover with RAID Cards and Multiple HBAs* for important information on supported configurations.

Connecting Multiple Backplanes in a Single Channel Environment

This section describes the cables used when cascading from a single HBA. These connections use CBL-SAST-0531 internal cables and CBL-SAST-0573 external cables.

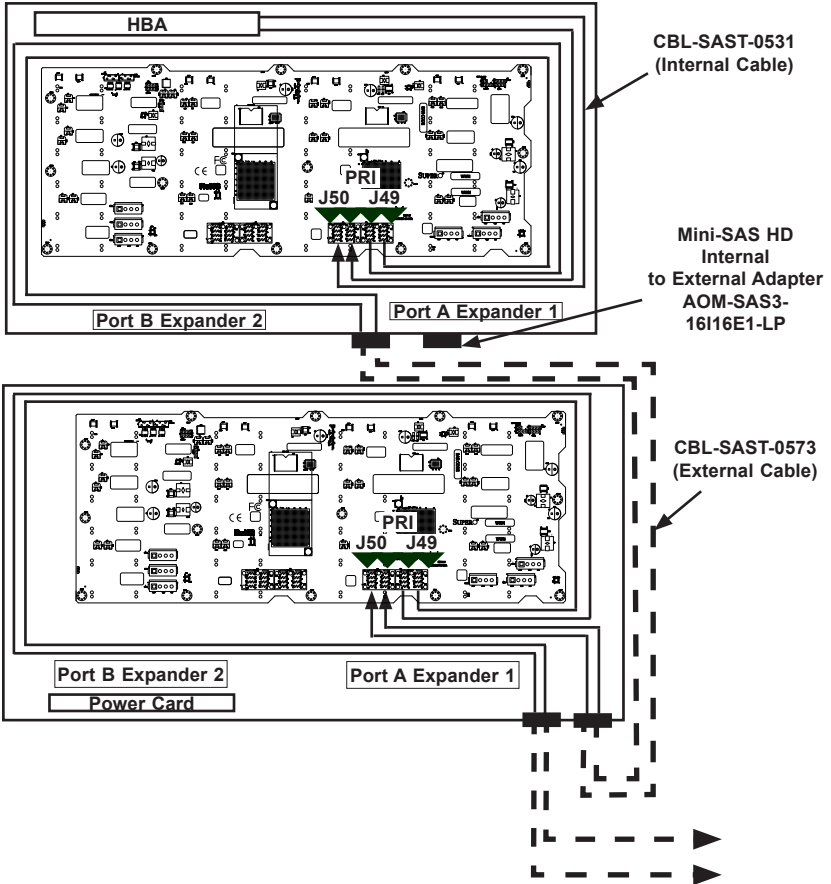

Figure C-14: Single HBA Configuration

Single HBA Configuration Cables



Figure C-15: External Mini-SAS HD to External Mini-SAS HD Cable

Cable Name: 1 Meter External Mini-SAS HD to External Mini-SAS HD Cable

Part #: CBL-SAST-0573

Ports: Single

Placement: External Cable

Description: External cascading cable, connects ports between servers and JBODs.

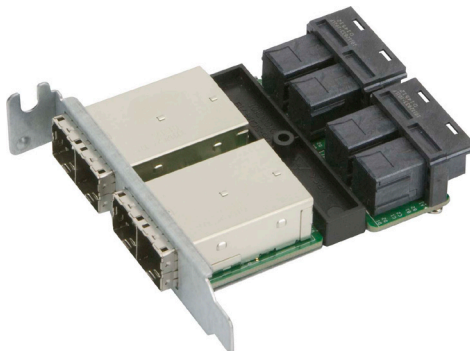

Figure C-16: Mini-SAS HD Internal to External Adapter

Cable Name: 16-port Mini-SAS HD Internal to External Cable Adapter with LP Bracket

Part #: AOM-SAS3-16I16E-LP

Ports: Four wide-ports (sixteen ports total)

Placement: Internal cable with adapter

Description: Internal cable, connects the SAS3 backplane to external ports.

Connecting Multiple Backplanes in a Dual Channel Environment

This section describes the cables used when cascading from dual HBAs. These connections use CBL-SAST-0531 internal cables and CBL-SAST-0573 external cables.

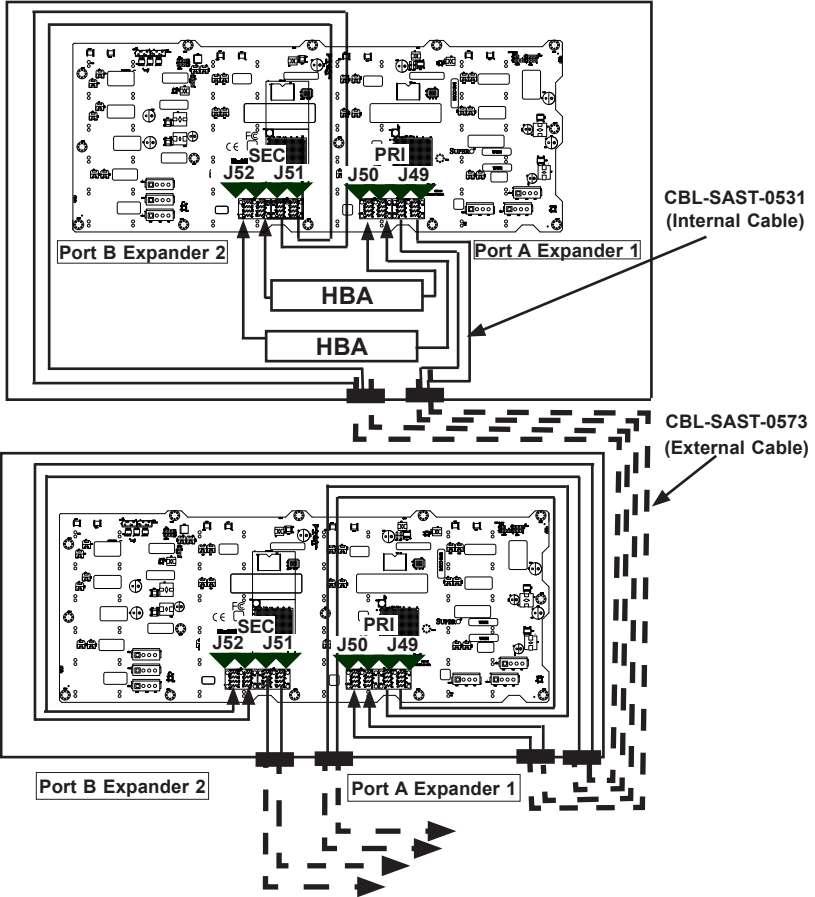

Figure C-17: Dual HBA Configuration

IMPORTANT: See Section 3-3 of this manual, *Failover with RAID Cards and Multiple HBAs* for important information on supported configurations.

Cascading BPN-SAS3-846EL and BPN-SAS3-847EL

For instructions on cascading BPN-SAS3-846EL and BPN-SAS3-847EL together, see page Appendix E of this manual.

Appendix D

BPN-SAS3-847EL Backplane Specifications

To avoid personal injury and property damage, carefully follow all the safety steps listed below when accessing your system or handling the components.

D-1 ESD Safety Guidelines

Electrostatic Discharge (ESD) can damage electronic components. To prevent damage to your system, it is important to handle it very carefully. The following measures are generally sufficient to protect your equipment from ESD.

- Use a grounded wrist strap designed to prevent static discharge.
- Touch a grounded metal object before removing a component from the antistatic bag.
- Handle the backplane by its edges only; do not touch its components, peripheral chips, memory modules or gold contacts.
- When handling chips or modules, avoid touching their pins.
- Put the card and peripherals back into their antistatic bags when not in use.

D-2 General Safety Guidelines

- Always disconnect power cables before installing or removing any components from the computer, including the BPN-SAS3-847EL series backplane.
- Make sure that the backplane is properly and securely on the motherboard to prevent damage to the system due to power outages.

D-3 An Important Note to Users

All images and layouts shown in this user's guide are based upon the latest backplane revision available at the time of publishing. The card you have received may or may not look exactly the same as the graphics shown in this manual.

D-4 Introduction to the BPN-SAS3-847EL Backplane

The BPN-SAS3-847EL backplane has been designed to utilize the most up-to-date technology available, providing your system with reliable, high-quality performance.

This manual reflects BPN-SAS3-847EL Revision 1.00, the most current release available at the time of publication. Always refer to the Supermicro Web site at www.supermicro.com for the latest updates, compatible parts and supported configurations.

D-5 Overview of the BPN-SAS3-847EL1/EL2 Backplanes

The BPN-SAS3-847EL1 and BPN-SAS3-847EL2 model backplanes are identical, except that the BPN-SAS3-847EL2 backplane has duplicate secondary components which are not found on the BPN-SAS3-847EL1. The BPN-SAS3-847EL2 is divided into a two sections, with the primary components on the upper portion of the board and the secondary components on the lower portion. SAS3 backplanes are not compatible with legacy SAS (3 Gbps), SATA (1.5 Gbps) backplanes or lower.

D-6 Front Connectors

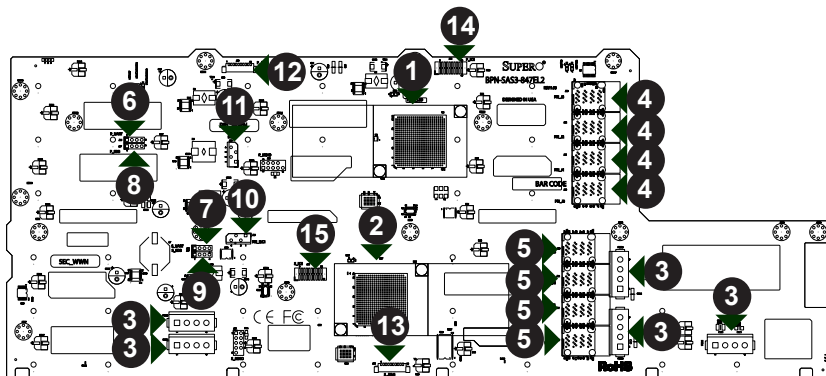

Figure D-1: BPN-SAS3-847EL1/EL2 Connectors and Components

- | | |
|---|--|
| 1. Primary Expander Chip. | 8. Primary SDB Connector: P_SDB (J27), for manufacturer's use. |
| 2. Secondary Expander Chip (not present on EL1 single port backplanes). | 9. Secondary SDB Connector: S_SDB (J37), for manufacturer's use only, not present on EL1 backplanes. |
| 3. Backplane Power Connectors: PWR1 through PWR5. | 10. I ² C Connector: PRI_I2C1 (J29). |
| 4. Primary SAS Ports: PRI_J0 (J20), PRI_J1 (J21), PRI_J2 (J22) and PRI_J3 (J23) | 11. SMB Connector: SMB (J28). |
| 5. Secondary SAS Ports: SEC_J0 (J30), SEC_J1 (J31), SEC_J2 (J32. (not present on EL1 single port backplanes). | 12. Primary JTAG Connector: P_JTAG (J25), for manufacturer's use. |
| 6. Primary UART Connector: P_UART (J26) for manufacturer's use only. | 13. Secondary JTAG Connector: S_JTAG (J35), for manufacturer's use, (not present on EL1 single port backplanes). |
| 7. Secondary UART Connector: S_UART(J36) for manufacturer's use, not present on EL1 backplanes. | 14. Primary ICE connector: P_ICE (J24), for manufacturer's use. |
| | 15. Secondary ICE connector: S_ICE (J34), for manufacturer's use. |

D-7 Front Connector and Pin Definitions

1. -2. Primary and Secondary Expander Chips

The primary and secondary expander chips allow the backplane to support dual port, cascading, and failover configurations.

3. Backplane Power Connectors

The 4-pin connectors, designated PWR1 - PWR5 provide power to the backplane. See the table on the right for pin definitions.

Backplane Main Power 4-Pin Connector	
Pin#	Definition
1	+12V
2 and 3	Ground
4	+5V

4. - 5. Primary and Secondary SAS Ports

The primary SAS connectors are designated PRI_J0 (J20), PRI_J1 (J21), PRI_J2 (J22) and PRI_J3 (J23). The secondary SAS Ports are designated SEC_J0 (J30), SEC_J1 (J31), SEC_J2 (J32). and are not present on EL1 single port backplanes.

6. - 7. Primary and Secondary UART Connectors

The primary UART connector is designated P_UART (J26). The secondary UART connector is designated S_UART(J36) and is not present on BPN-SAS3-847EL1. UART connectors are used for manufacturer's diagnostic purposes only.

8. - 9. SDB Connectors

The Primary SDB connector is designated P_SDB (J27). The secondary SDB connector is designated S_SDB (J37). (Not present on BPN-SAS3-847EL1 backplanes) These are debug connectors used for the manufacturer's diagnostic purposes only.

10. I²C Connector

The I²C connector. is designated PRI_I2C1 (J29). The secondary I²C connector is designated I2C4 and J47. (Not present on BPN-SAS3-847EL1 backplanes)

11. SMB Connector

The SMB connector. is designated SMB (J28).

12. - 13. JTAG Connectors

The Primary JTAG connector is designated P_JTAG (J25). The secondary JTAG connector is designated S_JTAG (J35) and is not present on BPN-SAS3-847EL1 backplanes. These are connectors for the manufacturer's test purposes only.

14. - 15. ICE Connectors

The Primary ICE connector is designated P_ICE (J26). The secondary ICE connector is designated S_ICE (J35) and is not present on BPN-SAS3-847EL1 backplanes. These are connectors for the manufacturer's test purposes only.

D-8 Front Jumper Location and Settings

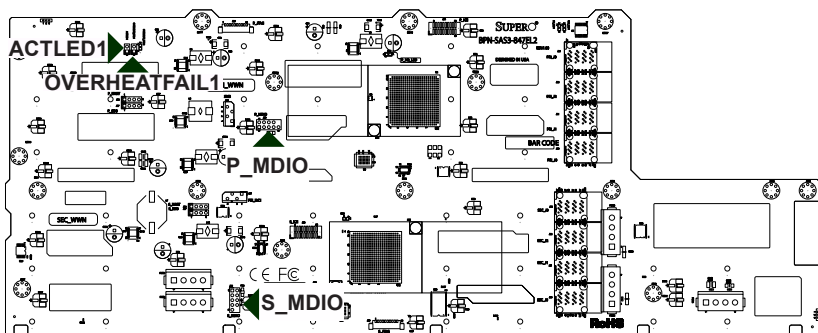
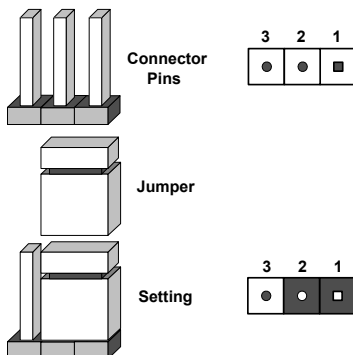

Figure D-2: Front Jumpers

Explanation of Jumpers

To modify the operation of the backplane, jumpers can be used to choose between optional settings. Jumpers create shorts between two pins to change the function of the connector. Pin 1 is identified with a square solder pad on the printed circuit board. Note: On two pin jumpers, "Closed" means the jumper is on and "Open" means the jumper is off the pins.



General Jumper Settings		
Jumper	Jumper Settings	Note
ACTLED1	Open: Disabled (Default) Closed: Enabled	Activity LED test.
OVERHEATFAIL1	Open: Disabled (Default) Closed: Enabled	Indicates an overheated condition (primary section)
P_MDIO	Open: Disabled (Default) Closed: Enabled	Primary management data in/out (J38). For manufacturer's use only
S-MDIO	Open: Disabled (Default) Closed: Enabled	Secondary management data in/out. (J39). For manufacturer's use only

D-9 Front LED Indicators

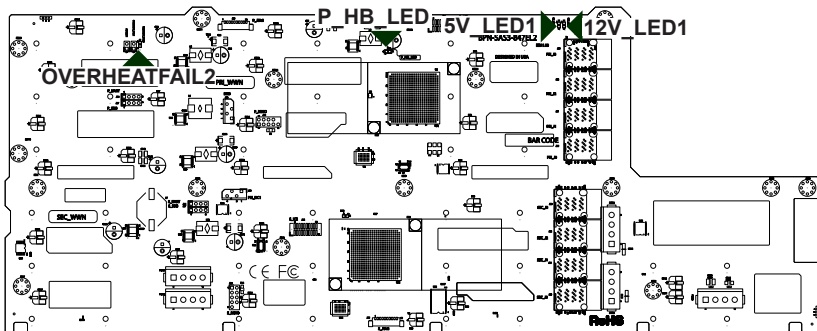

Figure D-3: Front LEDs

Backplane LEDs			
LED	Normal State	Abnormal State	Specification
12V_LED1	On	Off	12V power status
P_HB_LED	Blinking	Off	Primary expander heartbeat indicator
5V_LED1	Off	On	5V power status
OVERHEATFAIL2	Off	On	System overheat/failure LED

D-10 Rear Connectors and LED Indicators

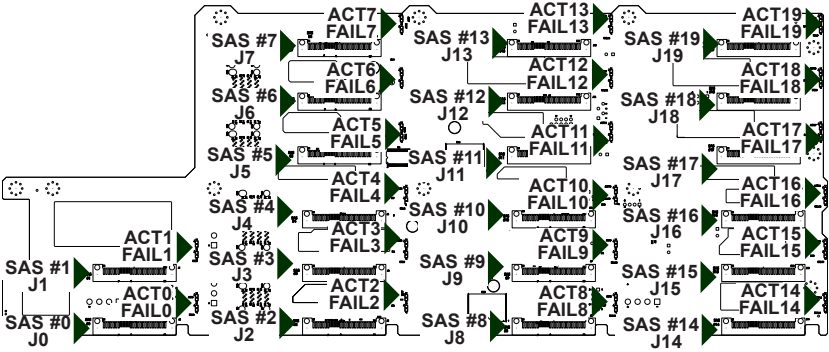

Figure D-4: Rear Connectors and LEDs

Rear SAS Connectors			
Rear Connector	SAS Drive Number	Rear Connector	SAS Drive Number
SAS #0	SAS HDD #0	SAS #10	SAS HDD #10
SAS #1	SAS HDD #1	SAS #11	SAS HDD #12
SAS #2	SAS HDD #2	SAS #12	SAS HDD #12
SAS #3	SAS HDD #3	SAS #13	SAS HDD #13
SAS #4	SAS HDD #4	SAS #14	SAS HDD #14
SAS #5	SAS HDD #5	SAS #15	SAS HDD #15
SAS #6	SAS HDD #6	SAS #16	SAS HDD #16
SAS #7	SAS HDD #7	SAS #17	SAS HDD #17
SAS #8	SAS HDD #8	SAS #18	SAS HDD #18
SAS #9	SAS HDD #9	SAS #19	SAS HDD #19

Rear LED Indicators		
Rear LED	Hard Drive Activity	Failure LED
SAS #0	ACT0	FAIL0
SAS #1	ACT1	FAIL1
SAS #2	ACT 2	FAIL2
SAS #3	ACT3	FAIL3
SAS #4	ACT4	FAIL4
SAS #5	ACT5	FAIL5
SAS #6	ACT6	FAIL6
SAS #7	ACT7	FAIL7
SAS #8	ACT8	FAIL8
SAS #9	ACT 9	FAIL9
SAS #10	ACT10	FAIL10
SAS #11	ACT11	FAIL11
SAS #12	ACT12	FAIL12
SAS #13	ACT13	FAIL13
SAS #14	ACT14	FAIL14
SAS #15	ACT15	FAIL15
SAS #16	ACT16	FAIL16
SAS #17	ACT17	FAIL17
SAS #18	ACT18	FAIL18
SAS #19	ACT19	FAIL19

Notes

D-11 Single and Dual Port Expanders

SAS connectors PRI-J1 to J4 and SEC-J1 to J4 are bidirectional and can be treated as input or output.

Single Ports

BPN-SAS3-847EL1 backplanes have a single port expander that accesses all of the drives and supports cascading.

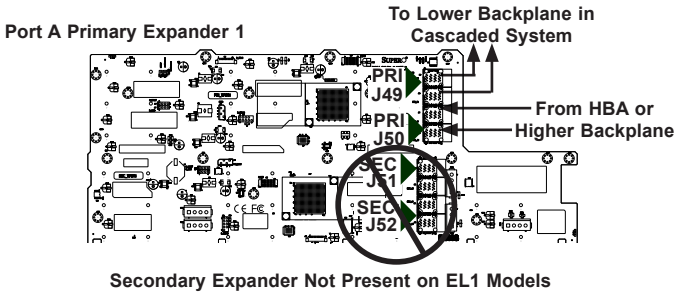

Figure D-5: BPN-SAS3-847EL1 Single Port Configuration

Dual Ports

BPN-SAS3-847EL2 model backplanes have dual-port expanders that access all of the hard drives. These dual-port expanders support cascading, failover, and recovery.

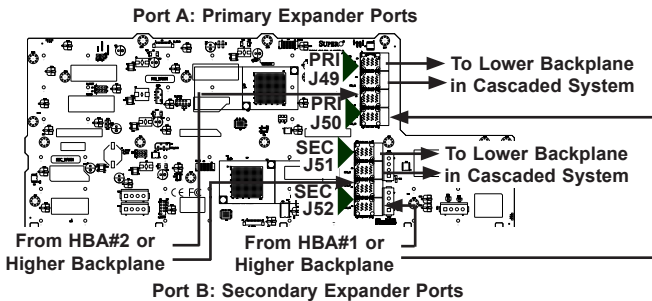

Figure D-6: BPN-SAS3-847EL2 Dual Port Configuration

D-12 Failover

The BPN-SAS3-847EL2 model backplane has two expanders which enable effective failover and recovery.

Single Host Bus Adapter

In a single host bus configuration, the backplane connects to one host bus adapter.

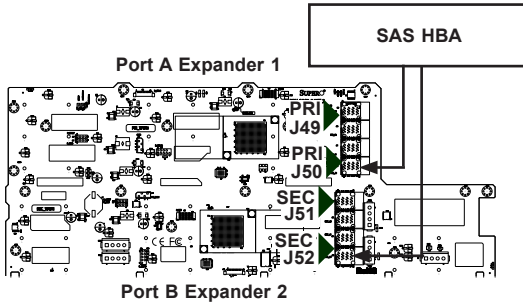

Figure D-7: Single HBA

Single Host Bus Adapter Failover

If the expander or data path in Port A fails, the system automatically switches to Port B with application software or failover support.

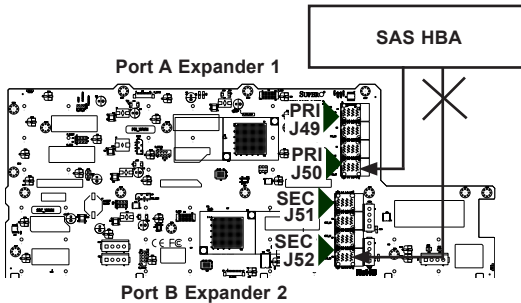

Figure D-8: Single HBA Failover

D-13 Failover with RAID Cards and Multiple HBAs

The BPN-SAS3-847EL backplane may be configured for failover with multiple HBAs using either RAID controllers or HBAs to achieve failover protection.

RAID Controllers: If RAID controllers are used, then the failover is accomplished through port failover on the same RAID card.

HBAs: If multiple HBAs are used to achieve failover protection and load balancing, **Linux MPIO software must be installed and correctly configured to perform the load balancing and failover tasks.**

Dual Host Bus Adapter

In a dual host bus configuration, the backplane connects to two HBA's.

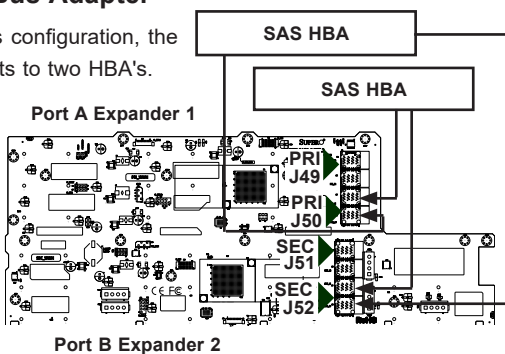

Figure D-9: Dual HBA

Dual Host Bus Adapter Failover

If the expander or data path in Port A fails, the system automatically switches to Port B. This maintains a full connection to all drives.

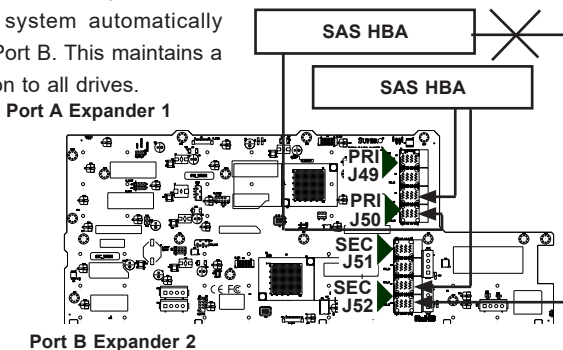

Figure D-10: Dual HBA Failover

IMPORTANT: For RAID controllers, redundancy is achieved through port failover. For multiple HBAs MPIO software is required to achieve failover protection.

D-14 Connecting HBAs to the Backplane

Connecting an Internal HBA to the Backplane

The following section lists the most common cables used to connect the HBA to the backplane.

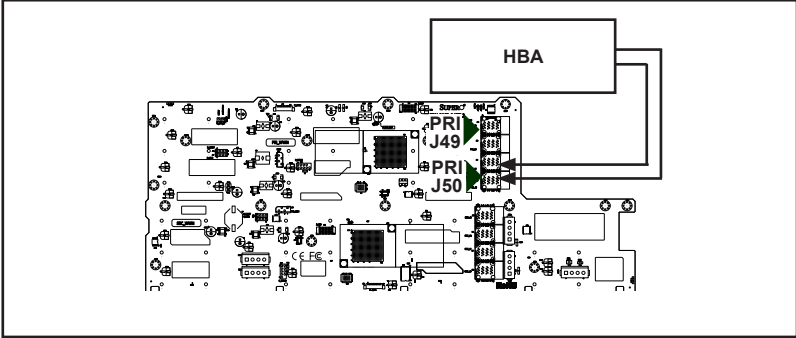

Figure D-11: Single Internal Host Bus Adapter

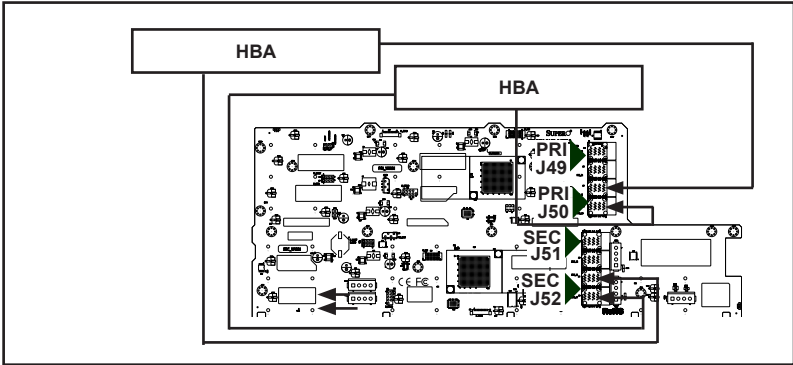

Figure D-12: Dual Internal Host Bus Adapter

Supported Internal HBA Cables

Use the following cables to create connections between the internal HBA and BPN-SAS3-847EL model backplane. The cables required depend upon the HBA connector.

IMPORTANT: See Section 3-3 of this manual, *Failover with RAID Cards and Multiple HBAs* for important information on supported configurations.

Cable Name: Internal iPass (Mini-SAS) to HD (Mini-SAS)

Part #: CBL-SAST-0508-01 **Length:** 50 cm (19 inches)

Part #: CBL-SAST-0507-01 **Length:** 80 cm (31 inches)

Description: This cable has an iPass (SFF-8087/Mini-SAS) connector (36-pin) at one end and a Mini-SAS HD (SFF-8643) connector at the other end. It connects from the SAS2 HBA to the BPN-SAS3-847EL model backplane.

Cable name: Internal HD (Mini-SAS) to HD (Mini-SAS)

Part #: CBL-SAST-0568 **Length:** 35 cm (13 inches)

Part #: CBL-SAST-0593-01 **Length:** 60 cm (23 inches)

Part #: CBL-SAST-0531 **Length:** 80 cm (31 inches)

Description: This cable has a Mini-SAS HD (SFF-8643) connector at both ends. It connects from the SAS3 HBA to the BPN-SAS3-847EL model backplane.

Connecting an External HBA to the Backplane

This backplane supports external host bus adapters. In this configuration, the HBA and the backplane are in different physical chassis. This allows a JBOD (Just a Bunch Of Drives) configuration from an existing system.

Single External Host Bus Adapter

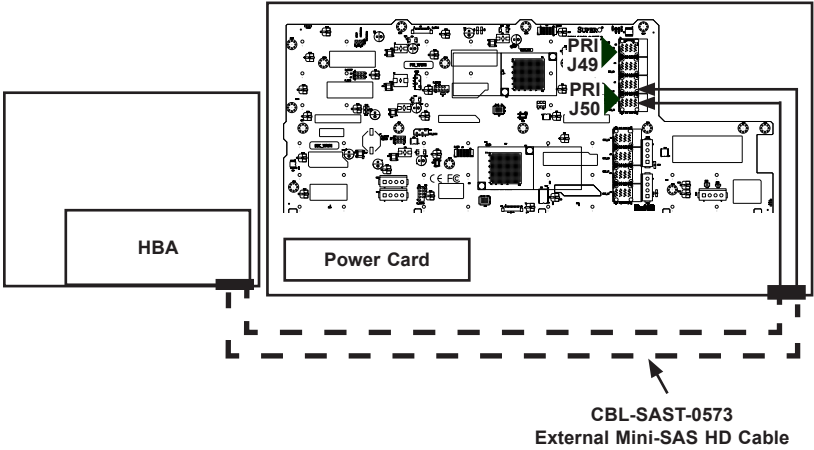

Figure D-13: Single External Host Adapter

Dual External Host Bus Adapter

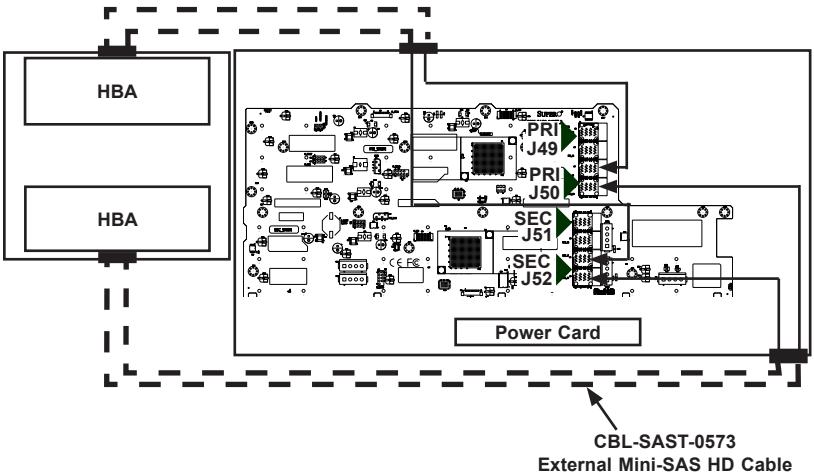

Figure D-14: Dual External Host Bus Adapter

IMPORTANT: See Section 3-3 of this manual, *Failover with RAID Cards and Multiple HBAs* for important information on supported configurations.

Connecting Multiple Backplanes in a Single Channel Environment

This section describes the cables used when cascading from a single HBA. These connections use CBL-SAST-0531 internal cables and CBL-SAST-0573 external cables.

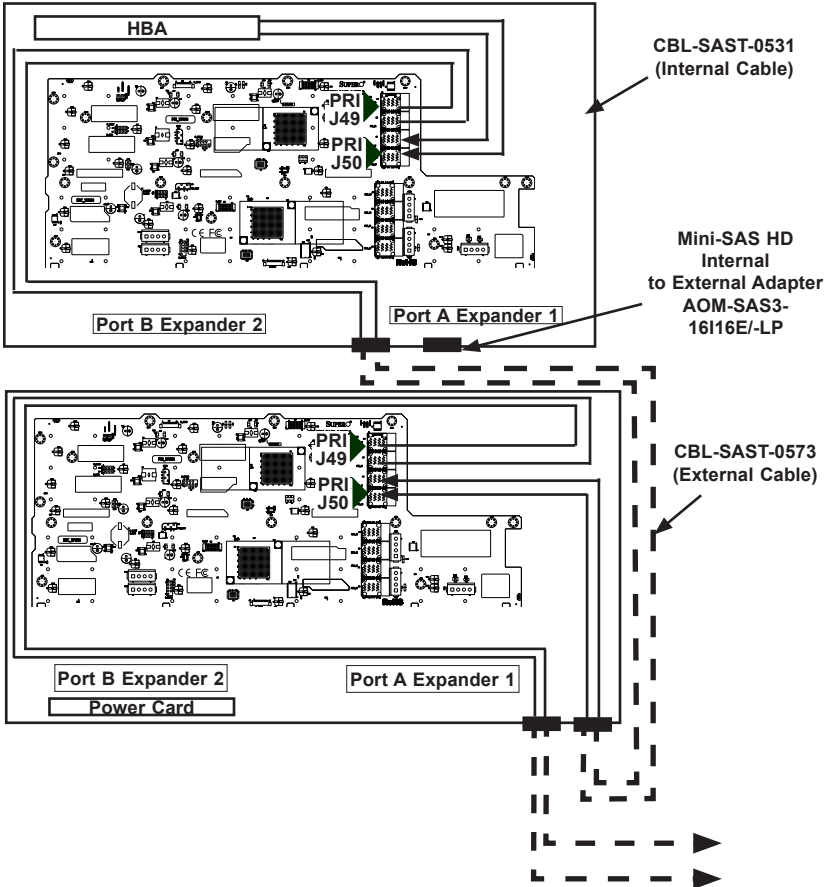

Figure D-15: Single HBA Configuration

Single HBA Configuration Cables



Figure D-16: External Mini-SAS HD to External Mini-SAS HD Cable

Cable Name: 1 Meter External Mini-SAS HD to External Mini-SAS HD Cable

Part #: CBL-SAST-0573

Ports: Single

Placement: External Cable

Description: External cascading cable, connects ports between servers and JBODs.

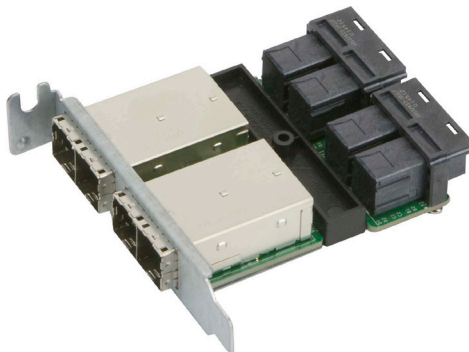

Figure D-17: Mini-SAS HD Internal to External Adapter

Cable Name: 16-port Mini-SAS HD Internal to External Cable Adapter with LP Bracket

Part #: AOM-SAS3-16I16E-LP

Ports: Four wide-ports (sixteen ports total)

Placement: Internal cable with adapter

Description: Internal cable, connects the SAS3 backplane to external ports. Also available without the LP bracket, part number AOM-SAS3-16I16E.

Connecting Multiple Backplanes in a Dual Channel Environment

This section describes the cables used when cascading from dual HBAs. These connections use CBL-SAST-0531 internal cables and CBL-SAST-0573 external cables.

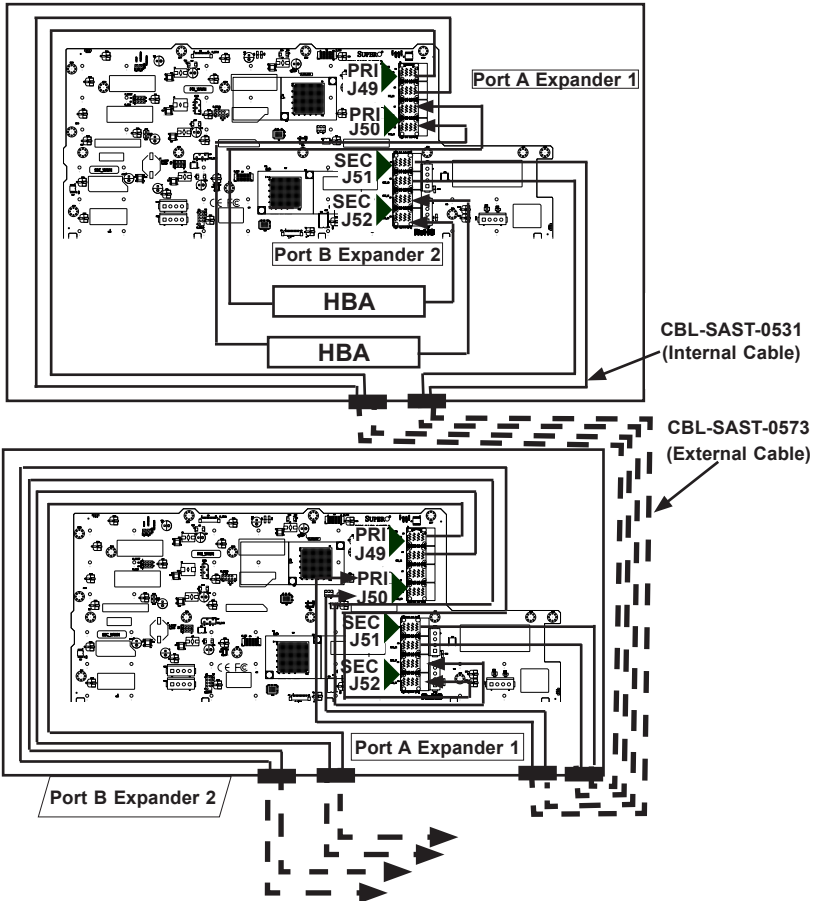

Figure D-18: Dual HBA Configuration

IMPORTANT: See Section 3-3 of this manual, *Failover with RAID Cards and Multiple HBAs* for important information on supported configurations.

Cascading BPN-SAS3-846EL and BPN-SAS3-847EL

For instructions on cascading BPN-SAS3-846EL and BPN-SAS3-847EL together, see page Appendix E of this manual.