



# **INSPUR SERVER USER MANUAL**

**NF5270M4**

**V1.0**

# Copyright Introduction

Document version: V1.0

Date: 5<sup>th</sup> Dec. 2014

Document Introduction: The 1<sup>st</sup> formal issuance.

## Abstract

The manual introduces issues closely related to maintenance such as specification, hardware operation, software configuration, service terms, fault diagnosis etc. of the server.

Readers of this guide will be deemed to have abundant knowledge about the server product, and will not cause any personal injury or product damage during operation and maintenance, for sufficient trainings received by them.

## Target Audience

This manual mainly adapts to the following personnel:

- Technical support engineers
- Product maintenance engineers

It is suggested that server maintenance operation shall be carried out by professional engineers with related server knowledge via referring to this manual.

## Warning:

This manual introduces this server's technical features and system installation and setup, which helps you to particularly understand and expediently use this server.

- ① Please do not disassemble the server's components arbitrarily. Please do not extend configuration or connect other peripheral devices arbitrarily. If needed, please be sure to conduct it with our authorization and guidance.
- ② Before disassembling the server's components, please be sure to disconnect all the power cords connected to the server.
- ③ BIOS and BMC setup is significant to the configuration of your server. If there are no special requirements, you are suggested to use the default value and not alter the parameter settings arbitrarily.

## Advertencia:

Este manual describe las características técnicas de este servidor, y la configuración e instalación del sistema, le ayudará a la comprensión más detallada y fácil al uso del servidor.

- ① Por favor, no desmonte los componentes del servidor, no amplie o conecte arbitrariamente otros dispositivos equipados. Cuando necesita hacer algún operación, asegúrese hacerla bajo nuestra autorización y orientación.
- ② Antes del desmontaje del componente del servidor, asegúrese de desconectar todos los cables conectados al servidor.
- ③ Los ajustes de BIOS y BMC son muy importantes. Si no hay requisitos especiales, por favor, utilice la configuración por defecto del sistema y no cambie los parámetros de la configuración.

# Table of Content

<b>1 SAFETY INTRODUCTION</b> .....	<b>1</b>
<b>2 PRODUCT SPECIFICATION INTRODUCTION</b> .....	<b>6</b>
2.1 Introduction.....	6
2.2 Features and Specification .....	8
2.3 Front Panel.....	9
2.4 Rear Panel .....	12
2.5 Mainboard Layout.....	14
2.6 Mainboard Jumper Introduction .....	15
<b>3 BIOS CONFIGURATION</b> .....	<b>16</b>
3.1 System BIOS Configuration Methods .....	16
3.2 BIOS Configuration .....	17
3.3Firmware Update .....	49
<b>4 BMC CONFIGURATION</b> .....	<b>52</b>
4.1 Introduction.....	52
4.2 Functional Modules .....	53
4.3 Web Interface Introduction .....	54
4.4 Remote Control.....	58
4.5 Power Supply and Heat Radiation .....	59
4.6 BMC Configuration .....	60
4.7 Logs .....	64
4.8 Fault Diagnosis .....	65
4.9 System Maintenance .....	66
4.10 Command Line Function Introduction .....	67
4.11 Time Zone Table .....	71

<b>5 HARDWARE MAINTENANC111</b> .....	74
5.1 Tool Preparation.....	74
5.2 Parts Replacement.....	74
<b>6 FREQUENT FAULTS, DIAGNOSIS AND TROUBLESHOOTING</b> .....	85
6.1 Frequent Faults .....	85
6.2 Diagnosis and Exclusion Instructions.....	86
<b>7 SPECIFICATIONS</b> .....	89
7.1 USA FCC Statement .....	89
7.2 CE Statement of EU.....	89
7.3 China CCC.....	89
7.4 China Environmental Symbols .....	90

# 1 Safety Introduction

---

 **Warning:** the following warnings show that there are potential dangers that may cause property loss, personal injury or death:

---

- 1 The power supply equipment in the system may generate high voltage and dangerous electrical energy and thus cause personal injury. Please do not dismount the cover of the host or to dismount and replace any component in the system by yourself, unless otherwise informed by the distributor; only maintenance technicians trained by the distributor have the right to disassemble the cover of the host, dismount and replace the internal components.
- 2 Please connect the equipment to appropriate power supply, and the power should be supplied by external power supply which is indicated on the rated input label. To prevent your equipment from damages caused by momentary spike or plunge of the voltage, please use relevant voltage stabilizing equipment or uninterruptible power supply equipment.
- 3 If extended cables are needed, please use the three-core cables matched with correct earthed plug, and check the ratings of the extended cables to make sure that the sum of rated current of all products inserted into the extended cables do not exceed 80% of the limits of the rated currents of the extended cables.
- 4 Please be sure to use the supplied power supply component, such as power lines, power socket (if supplied with the equipment) etc. For the safety of equipment and the user, do not replace randomly power cables or plugs.
- 5 To prevent electric shock dangers caused by leakage in the system, please make sure that the power cables of the system and peripheral equipment are correctly connected to the earthed power socket. Please connect the three-core power line plug to the three-core AC power socket that is well earthed and easy to access, be sure to use the earthing pin of power lines and do not use the patch plug or the earthing pin unplugged with cables. In case of the earthing conductors not installed and it is uncertain whether there are appropriate earthing protections, please do not operate or use the equipment. Contact and consult with the electrician.
- 6 To avoid short circuit of internal components and fire or electric shock hazards, please do not fill any object into the open pores of the system.

- 7 Please place the system far away from the cooling plate and at the place with heat sources, and be sure not to block the air vents.
- 8 Be sure not to scatter food or liquid in the system or on other components, and do not use the product in humid and dusty environment.
9. CAUTION: Risk of Explosion if Battery is replaced by an Incorrect Type. Dispose of Used Batteries According to the Instructions.

ATTENTION: risque d'explosion si la batterie est remplacée par un type incorrect. Jetez les piles usagées selon les instructions.

The replacement of batteries with those of incorrect model may cause explosion. When replacement of batteries is required, please consult first the manufacturer and choose batteries of the same or a similar model recommended by the manufacturer. Do not dismount, extrude and pink the batteries or make the external connection point short circuit, and do not expose them in the environment over 60°C. Never throw them into fire or water. Please do not try to open or repair the batteries, and be sure to reasonably deal with the flat batteries and do not put the fl at batteries, the circuit boards that may include the batteries and other components with other wastes. For relevant battery recovery, please contact the local waste recovery and treatment mechanism.

10. Before installing equipment in the chassis, please install front and side supporting feet on the independent chassis; for cabinet connecting with other chassis, it shall install the front supporting foot first. If you fail to install correspondingly the supporting foot before installing equipment in the chassis, it may cause the cabinet to turn over in some cases, and thus may cause personal injury. Therefore, it is necessary to install supporting feet before installing equipment in the chassis. After installing the equipment and other components in the chassis, it can only pull out one component from the cabinet through its sliding component at one time. Pulling out several components at the same time may lead the cabinet to turn over and cause serious personal injury.
11. Please do not move the chassis independently. Considering the height and weight of the chassis, at least two people are needed to complete its movement.
12. Please do not carry out direct contact operation on power copper busbar when the cabinet is powered on, and it is prohibited to carry out direct short circuit of power copper busbar.
13. The product is Grade A product, and in the living environment, it may cause radio interference. In such case, it may need the user to take feasible measures for the interference.

14. Equipment intended for installation in Restricted Access Location.  
équipement conçu pour une installation dans Emplacement à accès restreint.

---

 **Note:** In order to help you use the equipment, the following considerations can help avoid the occurrence of problems that may damage the components or cause data loss etc.

---

- 1 In case of the following cases, please unplug the power line plug of products from the power socket and contact customer service department of the distributor:
  - 1) The power cables, extended cables or power plugs are damaged.
  - 2) The products get wet by water.
  - 3) The products have fallen off or been damaged.
  - 4) Objects fall into the products.
  - 5) When operating according to the operation instructions, the products cannot function normally.
- 2 If the system becomes damp, please dispose according to the following steps:
  - 1) Switch off the power supplies of the system and the equipment, disconnect them with the power socket, wait for 10 to 20 minutes, and then open the cover of the host.
  - 2) Move the equipment to the ventilation place to dry the system at least for 24 hours and make sure that the system is fully dried.
  - 3) Close the cover of the host, re-connect the system to the power socket, and then start the equipment.
  - 4) In case of operation failure or abnormal situation, please contact the distributor and get technical support.
- 3 Pay attention to the position of the system cables and power cables, wire them in places not to be stepped on or knocked down and ensure not to place other objectives on the cables.
- 4 Before dismounting the cover of host or contacting the internal components, you shall cool down the equipment first; to avoid damaging the main-board, please power off the system and wait for 5 seconds, and then dismount the components from the main-board or disconnect the connection of peripheral equipment of the system.
- 5 If there are modulator-demodulator, telecommunication or local area network options in the equipment, please pay attention to the following matters:



- 1) In case of thunder and lightning weather, please do not connect or use the modulator-demodulator. Otherwise, it may be subject to lightning strike.
  - 2) Never connect or use modulator-demodulator in moist environment.
  - 3) Never insert the modulator-demodulator or telephone cables to the socket of network interface controller (NIC).
  - 4) Before unpacking the product package, contacting or installing internal components or contacting un-insulated cables or jacks of the modulator-demodulator, please disconnect the modulator-demodulator cables.
- 6 In order to prevent the electrostatic discharge from damaging the electronic components in the equipment, please pay attention to the following matters:
- 1) You shall conduct off the static electricity on the body before dismounting or contacting any electronic component in the equipment. You can conduct off the static electricity on the body by contacting the metal earthing objects (such as the unpainted metal surface on the chassis) to prevent the static electricity on the body from conducting itself to the sensitive components.
  - 2) For electrostatic sensitive components not ready to be installed for application, please do not take them out from the antistatic package materials.
  - 3) During the work, please touch the earthing conductor or the unpainted metal surface on the cabinet regularly to conduct off the static electricity on the body that may damage the internal components.
- 7 When dismounting the internal components with the approval of distributor, please pay attention to the following matters:
- 1) Switch off the system power supply and disconnect the cables, including disconnecting any connection of the system. When disconnecting the cables, please grab the connector of cables and plug it out, and never pull the cables.
  - 2) Before dismounting the cover of cabinet or touching the internal components, the products need to be cooled down.
  - 3) Before dismounting and touching any electronic component in the equipment, you shall conduct off the static electricity on the body by touching the metal earthing objectives.
  - 4) During the dismounting process, the operation shall not be too big, so as to prevent damage to the components or scratching of the arms.
  - 5) Carefully deal with the components and plug-in cards, and please never touch, the

components or connection points on the plug-in cards. When taking the plug-in cards or components, you should grab the edges of the plug-in cards or components or their metal fixed supports.

- 8 During the process of cabinet installation and application, please pay attention to the following matters:
  - 1) After the installation of cabinet is finished, please ensure that the supporting feet have been fixed to the rack and supported to the ground, and all weight of the rack have been fell onto the ground.
  - 2) It shall install into the cabinet according to the sequences from the bottom to the top, and first install the heaviest component.
  - 3) When pulling out the components from the cabinet, it shall apply force slightly to ensure the cabinet to keep balance and stabilization.
  - 4) When pressing down the release latch of the sliding rail of components and sliding in or out, please be careful, as the sliding rail may hurt your figures.
  - 5) Never make the AC power branch circuit in the cabinet overload. The sum of cabinet load shall not exceed 80% of the ratings of branch circuits.
  - 6) Ensure that components in the cabinet have good ventilation.
  - 7) When repairing components in the cabinet, never step on any other components.

## 2 Product Specification Introduction

### 2.1 Introduction

This type is a kind of server product developed independently. It adopts Intel Grantley-EP platform, and uses Wellsburg chip set. It supports two mainstream Intel Xeon E5-26\*\* V3 series processors. It supports 20 DIMM DDR4 memory, reaching up to 2133MHz. It supports ECC Registered and multiple senior memory redundancy function.

It supports up to 2.5" x 27 SAS/SATA/SSD hot-plugging hard disks or 3.5" x 12 SAS/SATA/SSD hot-plugging hard disks.

Mainboard integrates Gigabit network cards of high performance, and supports network advanced features. Mainboard integrates BMC/KVM chips. 6 PCI-Express expansion slots available.

Supports SAS 3.0 (12Gb/s) or SAS Raid cards, and implements flexible SAS/SAS RAID solutions. Modular design on components such as structure, storage, PCI expansion, power supply and fan etc. Energy-saving and noise reduction design, equipped with PMbus power supply of high efficiency, supports DPNM function, and implements energy saving and consumption reducing.

- 2.5"×24 configuration (i.e. full configuration)

It supports 24 front set 2.5" SAS/SATA/SSD hard disks, and the related appearance is as shown in the following figure.



- 3.5"×8 configuration (i.e. full configuration)

It supports 8 front set 3.5/2.5" SAS/SATA/SSD hard disks, and the related appearance is as shown in the following figure.

Note: 3.5" hard disk bracket could hold 3.5"/2.5" hard disks.



- 3.5"×12 configuration (i.e. full configuration)

It supports 12 front set 3.5"/2.5" SAS/SATA/SSD hard disks, and the related appearance is as shown in the following figure.

Note: 3.5" hard disk bracket could hold 3.5"/2.5" hard disks.



- 2.5"×25 configuration (i.e. full configuration)

It supports 25 front set 2.5" SAS/SATA/SSD hard disks, and the related appearance is as shown in the following figure.



## 2.2 Features and Specification

<b>Processor</b>	
Processor Type	Intel dual-way Xeon E5-26XX V3 Series (supports up to two 135W)
Interface	Two Socket-R3 slots.
<b>Chip Group</b>	
Chip Group Type	PCH C610 (Wellsburg)
<b>Memory</b>	
Memory Type	DDR4 ECC RDIMM/LRDIMM memory
Single Inline Memory Module Qty.	20
Memory Volume	It supports up to 640GB (32GB for single)
<b>I/O Interface</b>	
USB Interface	2 rear set USB 3.0 interfaces, and 2 built-in USB 3.0 interfaces
Display Interface	1 front set VGA interface 1 rear set VGA interface
Serial Interface	1 rear set serial port
ID Indicator Interface	1 ID indicator (blue) and its press button
<b>Display Controller</b>	
Controller Type	Aspeed 2400 integrated in chip, with max. resolution supporting 1280*1024
<b>SAS Backplane</b>	
SAS3.0 backplane	It supports hot-plugging SAS/SATA/SSD hard disks.
<b>Network Card</b>	
Network Card Controller	The mainboard integrates 1 Intel I350 dual Gigabit network card, providing two 1000M adaptive RJ45 network ports. It supports 1 network sub-card.
<b>Management Chip</b>	
Management Chip	It integrates 1 independent 1000Mbps network interface, which is used in IPMI remote management.
<b>PCI Extension Slot</b>	
	<ul style="list-style-type: none"> <li>There're 6 onboard PCI Express 3.0 slots on the mainboard, riser cards support being inserted vertically, including: PCIE0: CPU0, 8X+1X, support half-height half-length riser card, support NCSI PCIE1: CPU1, 4X, support half-height half-length riser card PCIE2: CPU1, 16X, support half-height half-length riser card PCIE3: CPU1, 8X (16X slot, 8 lanes), support half-height half-length riser card PCIE4: CPU0, 16X, support half-height 3/4 length riser card PCIE5: CPU0, 8X, support half-height half-length riser card</li> </ul>

<b>Hard Disk</b>	
Hard Drive Type	Front set 2.5/3.5 inch SAS, SATA and SSD hard disks; Up to 2 rear set SATA and SSD hard disks could be supported. (Subject to actual type you purchased)
<b>External Storage Driver</b>	
CD Driver	Slim SATA DVD drive Note: When 3.5×12, 2.5×25 and 2.5×24 configure the third hard disk module set, the drive could not be supported, please select USB drive.
Drive U Disk	Optional drive U disk.
<b>Power Supply</b>	
Specification	Output power of sing/Double power 550W/800W and above; 1+1 redundancy; 2 power modules; it supports PMBus power supply, and implements Node Manager 3.0 function.
Power Input	Please refer to power input on nameplate tag of the host.
<b>Physical Specification</b>	
External Dimension of Package	651 width × 307 height × 971 depth (unit: mm)
Host Size	447 width × 87 height × 720 depth (unit: mm)
Product Weight	Gross weight: 35.2kg (12 hard disks full configuration). (Gross weight includes: Host + Packing Box + Rail + Parts Kit)
<b>Environment Parameters</b>	
Working Environment Temperature	10°C -35°C
Storage & Transportation Temperature	-40°C -55°C
Working Humidity	35% -80% relative humidity
Storage & Transportation Humidity	20% -93% (40°C ) relative humidity

## 2.3 Front Panel

### 2.3.1 2.5×24 Disk Position

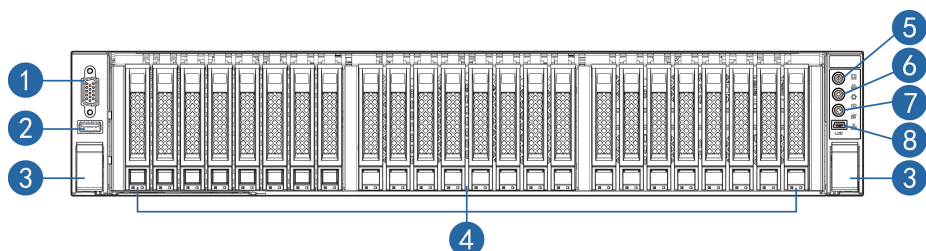

No.	Module Name
1	Front set VGA interface
2	Front set USB 3.0 interface
3	Securing buckle of server and cabinet
4	Front set hard disk slot
5	Server switch button
6	ID light and button
7	System fault indicator button
8	LCD liquid crystal management module interface

2.5×24 disk position hard disk sequence diagram

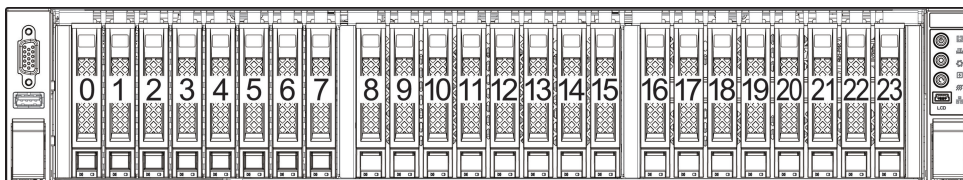

### 2.3.2 3.5×8 Disk Position

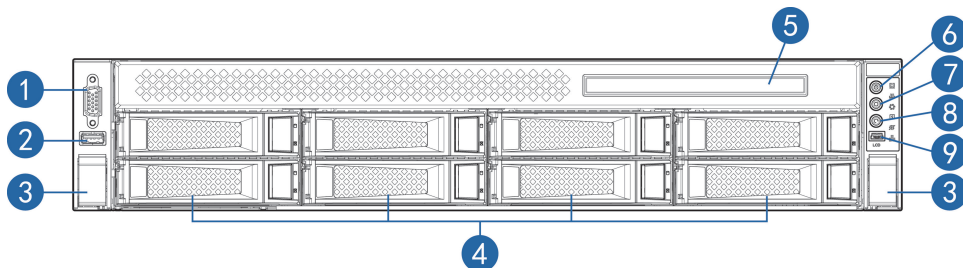

No.	Module Name
1	Front set VGA interface
2	Front set USB 3.0 interface
3	Securing buckle of server and cabinet
4	Front set hard disk slot
5	CD-ROM
6	Server switch button
7	ID light and button
8	System fault indicator button
9	LCD liquid crystal management module interface

3.5×8 disk position hard disk sequence diagram

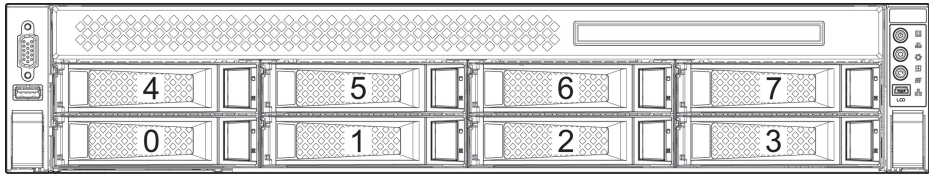

2.3.3 3.5×12 Disk Position

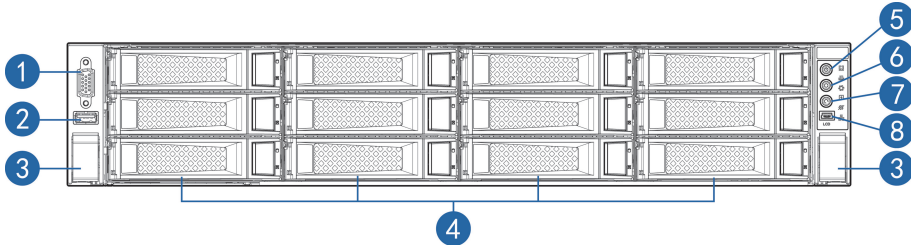

No.	Module Name
1	Front set VGA interface
2	Front set USB 3.0 interface
3	Securing buckle of server and cabinet
4	Front set hard disk slot
5	Server switch button
6	ID light and button
7	System fault indicator button
8	LCD liquid crystal management module interface

3.5×12 disk position hard disk sequence diagram

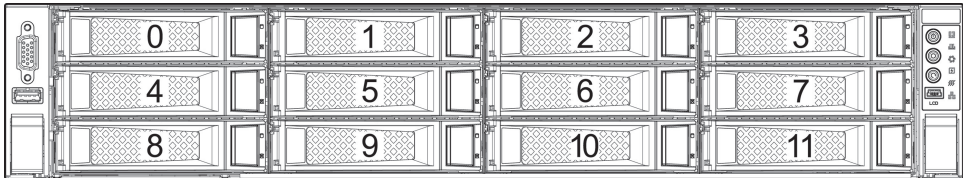

2.3.4 2.5×25 Disk Position

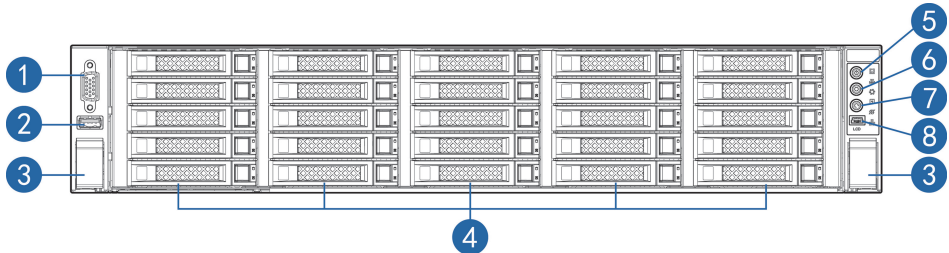



No.	Module Name
1	Front set VGA interface
2	Front set USB 3.0 interface
3	Securing buckle of server and cabinet
4	Front set hard disk slot
5	Server switch button
6	ID light and button
7	System fault indicator button
8	LCD liquid crystal management module interface

2.5×25 disk position hard disk sequence diagram

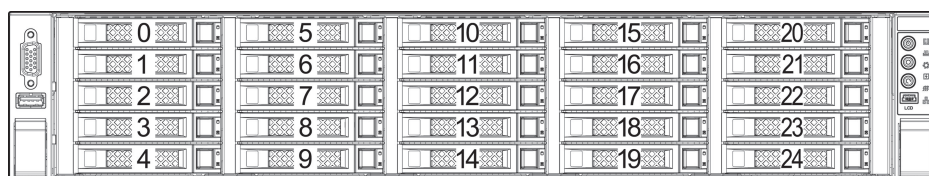

### 2.3.5 Front Control Panel Buttons and Indicators

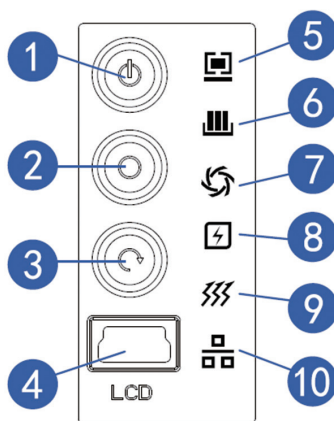

No.	Module Name
1	Server switch button
2	ID light and button
3	System fault indicator button
4	LCD liquid crystal management module interface
5	System fault indicator
6	Memory fault indicator
7	Fan fault indicator
8	Power fault indicator
9	System overheating indicator
10	Network status indicator

### 2.3.6 Indicators on Hard Disk Bracket

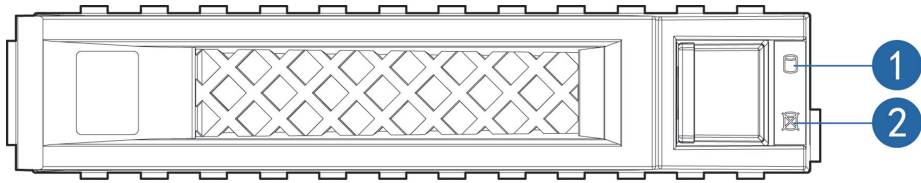

No.	Module Name	Description
1	Hard disk activity status indicator	Constant green: Normal Flashing green: Hard disk is reading and writing
2	Hard disk fault alarming indicator	Constant red: Hard disk fault Constant blue: Hard disk positioning Constant blue: In coordination with RAID rebuilding

## 2.4 Rear Panel

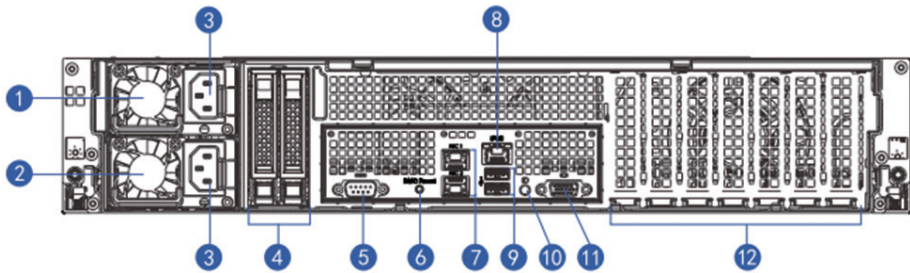

No.	Module Name
1	PSU0
2	PSU1
3	Power line interface
4	2.5 inch hard disk slot
5	Serial interface
6	BMC Reset
7	Gigabit network interface
8	IPMI interface
9	USB interface
10	ID light and button
11	VGA interface
12	PCIe slots

## 2.5 Mainboard Layout

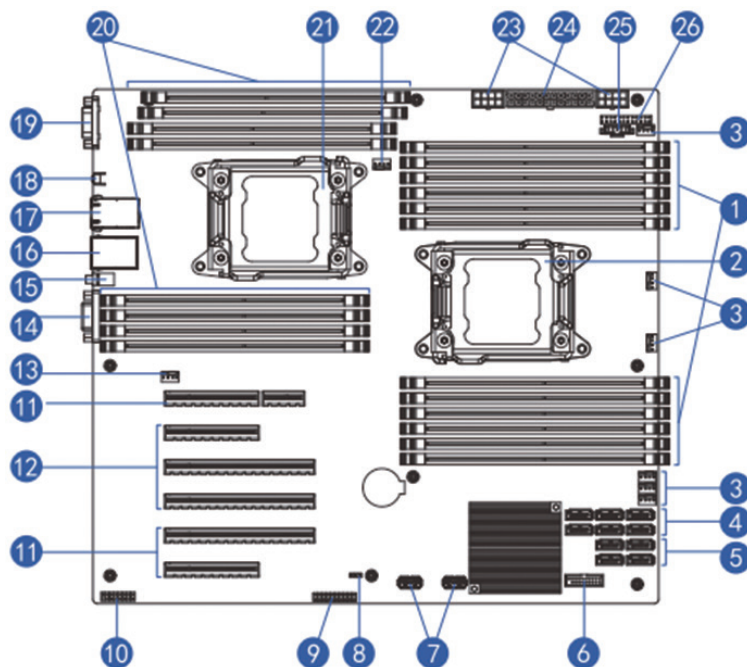

No.	Module Name
1	Memory slot (corresponding with CPU0)
2	CPU1
3	System fan interfaces
4	SATA interface
5	SSATA interface
6	Front set USB interface
7	Built-in USB interface
8	CMOS clear jumper
9	TCM interface
10	Front set VGA interface
11	PCIE slot (corresponding with CPU0)
12	PCIE slot (corresponding with CPU1)
13	CPU1 fan interface
14	Rear set VGA interface
15	ID light and button
16	IPMI interface/rear set USB interface (2)
17	2 Gigabit network ports

No.	Module Name
18	BMC Reset button
19	Serial interface
20	Memory slot (corresponding with CPU1)
21	CPU1
22	CPU0 fan interface
23	8pin power interface
24	24pin power interface
25	PMBUS communication interface
26	Front control panel interface

## 2.6 Mainboard Jumper Introduction

### 2.6.1 Clear CMOS Jumper Introduction

See [2.5 Mainboard Layout] for jumper positions.

Jumper No.	Function Description	Jumper Functions
CLR_CMOS	CMOS clear jumper	Short-circuit pin1-2, to restore normal status; short-circuit pin2-3, to clear CMOS.

#### Note:

It is required to shut down the system, as well as disconnect power supply during CMOS cleaning, and hold for 5 seconds after short-circuiting Pin2-3; then short-circuit Pin1 and Pin2 of CLR\_CMOS jumper with a jumper cap (the default status), to restore its original status.

## 3 BIOS Configuration

This chapter introduces BIOS function setup and mainboard jumper of the server. All operations described in this section are only limited to operators or administrators with system maintenance qualification.

BIOS is a basic input and output system. The system parameter and the hard drive parameter can be adjusted through special set program. BIOS has great influence on the system start and running so that setting parameters improperly may arise the conflict among the hardware resource, or fall down the system run performance. Hence understanding the BIOS setup is significant to the configuration of your server. If no especial requirement, you are suggested to use the default value and not alter the parameters optionally.

### Note:

- 
1. Before the server BIOS setup is altered, please record the corresponding original setup. Hence when there are operating problems in the system due to the option altered, the setup can revert.
  2. Ordinarily the factory default system value is the optimized setup. Don't try to alter the parameters before you understand their denotations.
  3. The common setup is introduced in detail in this paper. The less referred options in the application procedure are simply explained or not.
  4. The content of the BIOS is diverse based on the different configurations of the products; hence the detailed introduction is elided.
- 

### 3.1 System BIOS Configuration Methods

Power on the server, system starts to boot, when the following content appears below The distributor logo on the screen:

“Press <DEL> to SETUP or <TAB> to POST or <F12> to PXE Boot.”, press [DEL] button, when “Entering Setup...” appears on bottom right on the screen, it will enter system BIOS configuration later, and you could select options using arrow buttons on BIOS main menu to enter sub-menu.



**Note:** Options in grey are not available. Options with symbol “▶”, have a sub-menu.

---

Control key instruction table

Press Key	Function
<Esc>	Exit or return from sub-menu to main menu.
<←> or <→>	Select a menu.
<↑> or <↓>	Move the cursor up or down.
<Home> or <End>	Move the cursor to top or bottom of the screen.
<+> or <->	Select the previous or next numerical value or setting of the current one.
<F1>	Help
<F2>	Restore the last configuration.
<F9>	Restore default configuration.
<F10>	Save and exit
<Enter>	Execute commands or select a sub-menu.

## 3.2 BIOS Configuration

### 3.2.1 Main Menu



Main Menu Interface Instruction Table

Interface Parameters	Function Description
BIOS Information	Displays current BIOS information.
Processor Information	Displays CPU information.
Memory Information	Displays memory volume and current speed.
System Date(Day mm/dd/yyyy) System Time (hh/mm/ss)	Displays system time.
Access Level	Current access level

### 3.2.2 Advanced Menu

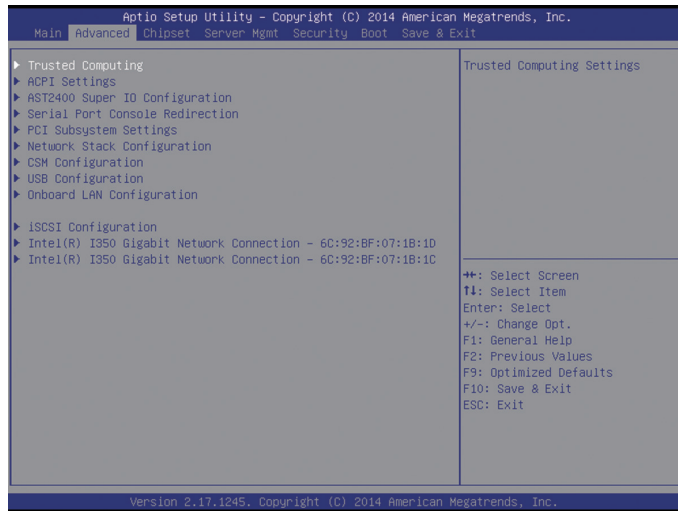

Advanced Menu Interface Instruction Table

Interface Parameters	Function Description
Trusted Computing	Trustable computing configuration
ACPI Settings	Advanced configuration and power interface settings
AST2400 Super IO Configuration	AST2400 I/O chip parameter configuration
Serial Port Console Redirection	Serial port console redirection settings
PCI Subsystem Settings	PCI subsystem settings
Network Stack Configuration	Network stack configuration
CSM Configuration	CMS configuration
USB Configuration	USB configuration
Onboard LAN Configuration	Onboard network card configuration

#### 3.2.2.1 Trusted Computing

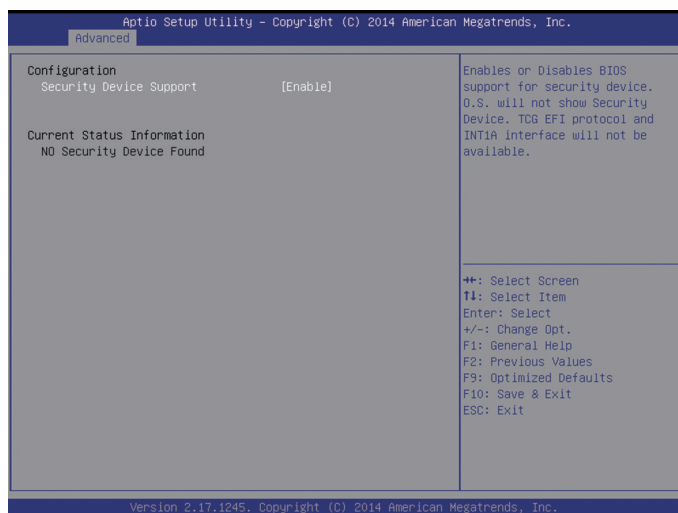

### Trusted Computing Menu Interface Instruction Table

Interface Parameters	Function Description
Security Device Support	BIOS's security device support settings
Current Status Information	Status information of the current security device

### 3.2.2.2 ACPI Settings

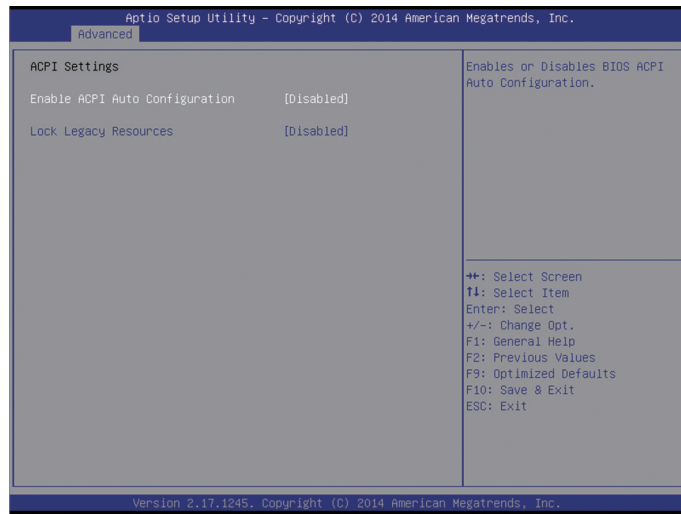

### Advanced Menu Interface Instruction Table

Interface Parameters	Function Description
Enable ACPI Auto Configuration	To allow ACPI's automatic configuration.
Lock Legacy Resources	The locking legacy resources setting

### 3.2.2.3 AST2400 Super IO Configuration

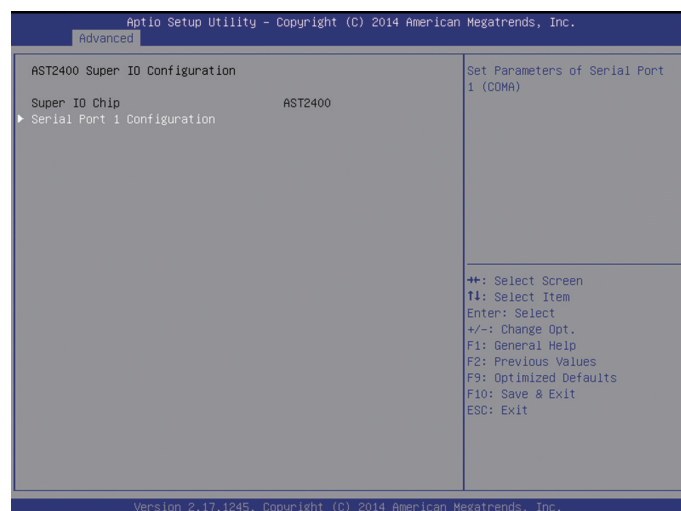



## AST2400 Super IO Configuration Menu Interface Instruction Table

Interface Parameters	Function Description
Super IO Chip	The current I/O chip
Serial Port 1 Configuration	Serial port 1 configuration

### 3.2.2.4 Serial Port Console Redirection

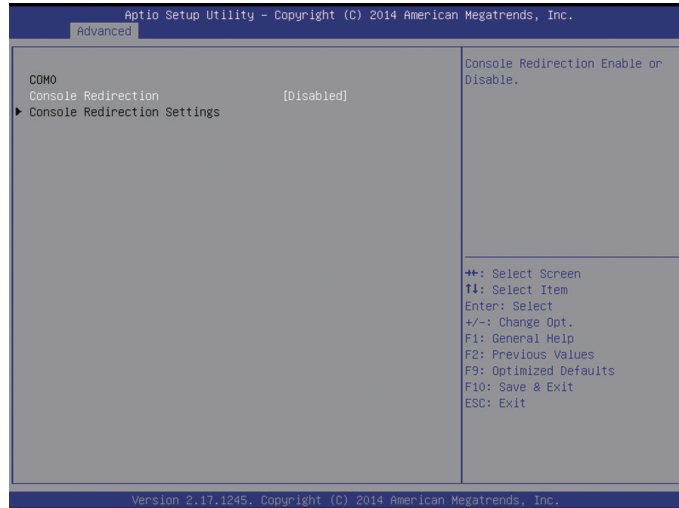

### Serial Port Console Redirection Menu Interface Instruction Table

Interface Parameters	Function Description
Console Redirection	The console redirection switching settings
Console Redirection Settings	The console redirection parameter settings

#### 3.2.2.4.1 Console Redirection Settings

When the Console Redirection option is set to [Enabled], the Console Redirection Settings menu is started.

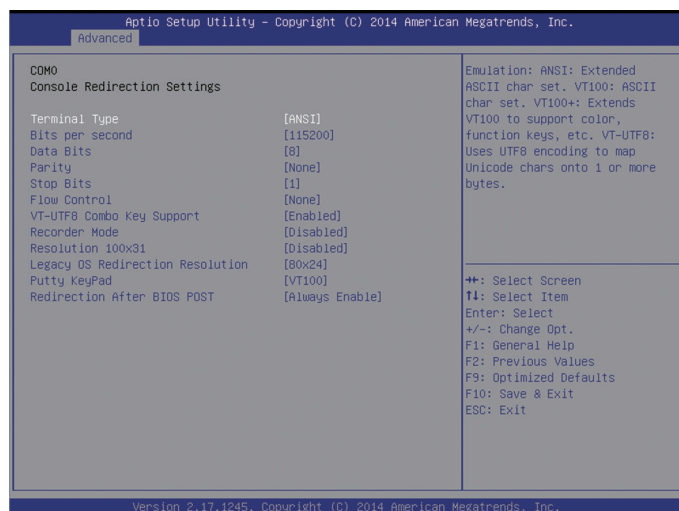

### Console Redirection Settings Menu Interface Introduction

Interface Parameters	Function Description
Terminal Type	Terminal type settings
Bits per second	Baud rate settings
Data Bits	Data bits settings
Parity	Parity check settings
Stop Bits	Stop bits settings
Flow Control	Flow control settings
VT-UTF8 Combo Key Support	VT-UTF8 Combo key support settings
Recorder Mode	Recorder mode settings
Redirection 100×31	Expanded terminal resolution settings
Legacy OS Redirection Resolution	Terminal resolution settings of legacy OS
Putty KeyPad	Putty's functional keys and keyboard settings
Redirection After BIOS POST	Redirection after BIOS bootup settings

### 3.2.2.5 PCI Subsystem Settings

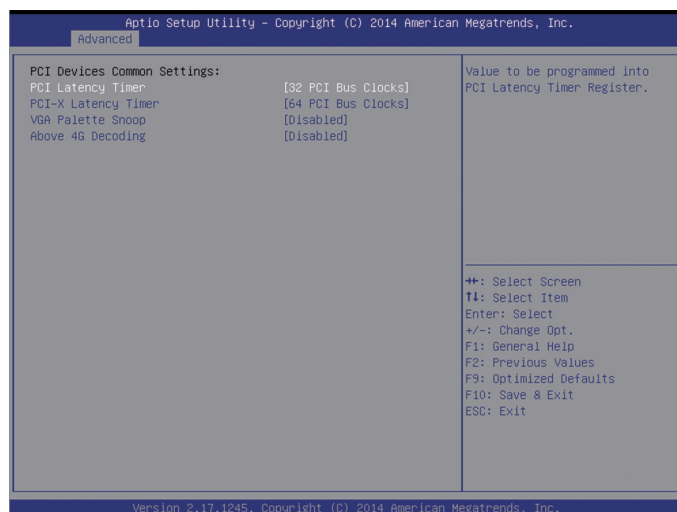

### PCI Subsystem Settings Menu Interface Instruction Table

Interface Parameters	Function Description
PCI Latency Timer	PCI delay timer settings
PCI-X Latency Timer	PCI-X delay timer settings
VGA Palette Snoop	VGA color correction settings
Above 4G Decoding	64bit equipment's decoding settings on address space larger than 4G.

### 3.2.2.6 CSM Configuration

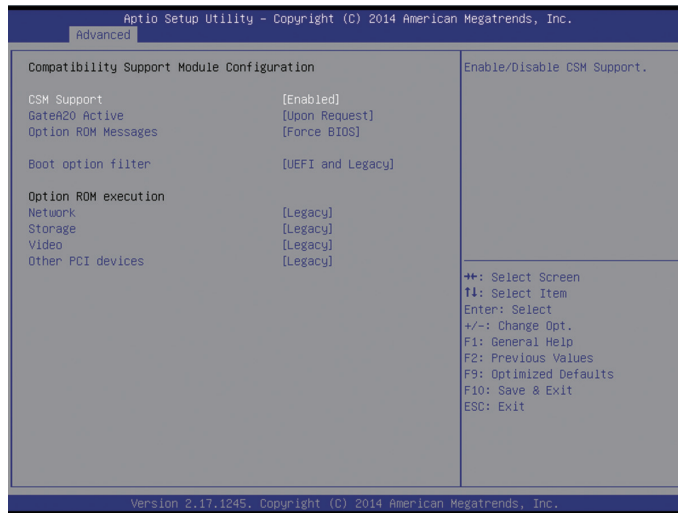

CSM Configuration Menu Interface Instruction Table

Interface Parameters	Function Description
CSM Support	CSM support settings
GateA20 Active	A20 address line's control mode settings
Option Rom Message	Option Rom display mode settings
Boot option filter	Boot option filter settings
Option ROM execution	Option Rom execution method
Network	Network card Option Rom execution method settings
Storage	Storage device Option Rom execution method settings
Video	Video device Option Rom execution method settings
Other PCI devices	Other PCI devices Option Rom execution method settings

### 3.2.2.7 USB Configuration

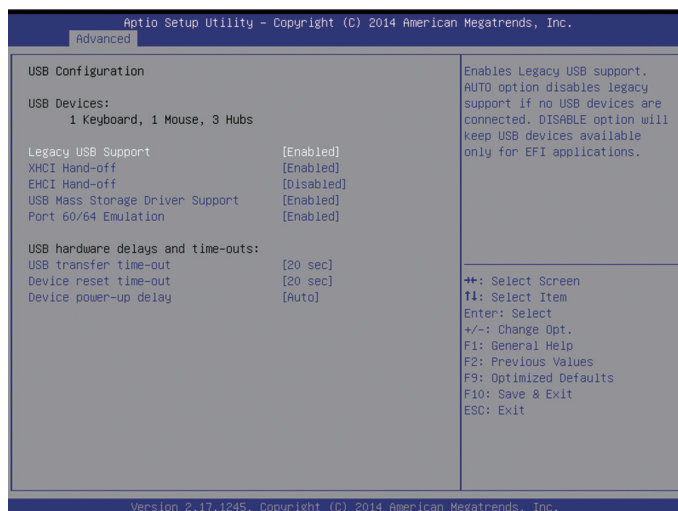

USB Menu Interface Instruction Table

Interface Parameters	Function Description
Legacy USB Support	Legacy USB device settings
XHCI Hand-off	Expansible host controller interface settings, orienting to USB 3.0.
EHCI Hand-off	Enhanced host controller interface settings, orienting to USB2.0.
USB Mass Storage Driver Support	USB mass storage driver support settings
Port 60/64 Emulation	USB port 60/64h emulation settings

3.2.2.8 Onboard LAN Configuration

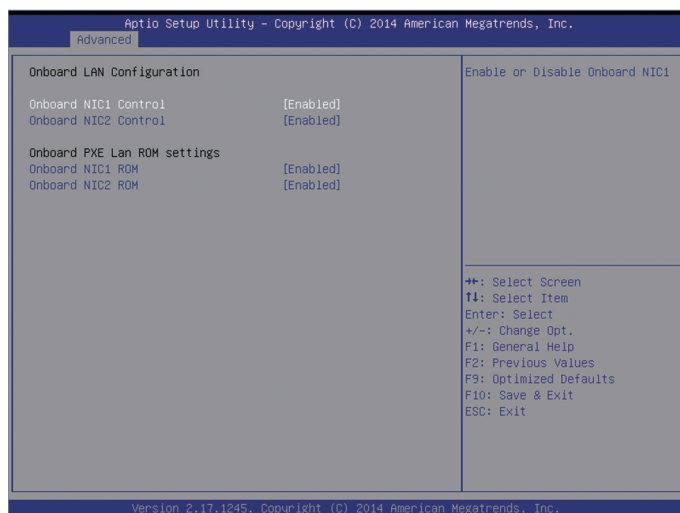

Onboard LAN Configuration Menu Interface Instruction Table

Interface Parameters	Function Description
Onbaord NIC1 Control	Onboard network card NIC1 switching settings
Onbaord NIC2 Control	Onboard network card NIC2 switching settings
Onboard NIC1 ROM	Onboard network card NIC1 PXE Oprom switching settings
Onboard NIC2 ROM	Onboard network card NIC2 PXE Oprom switching settings

### 3.2.3 Chipset Menu

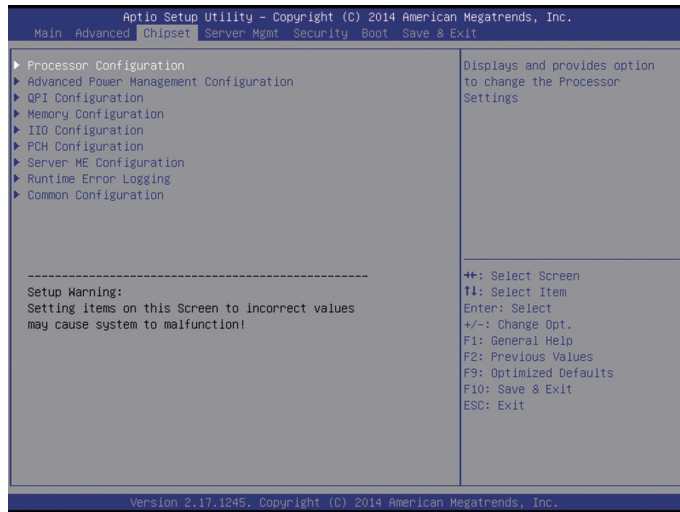

Chipset Menu Interface Instruction Table

Interface Parameters	Function Description
Processor Configuration	Processor configuration
Advanced Power Management Configuration	Advanced power management configuration
QPI Configuration	QPI configuration
Memory Configuration	Memory configuration
IIO Configuration	IIO configuration
PCH Configuration	PCH configuration
Server ME Configuration	Server ME configuration
Runtime Error Logging	Runtime error log configuration
Common Configuration	Common options configuration

#### 3.2.3.1 Processor Configuration

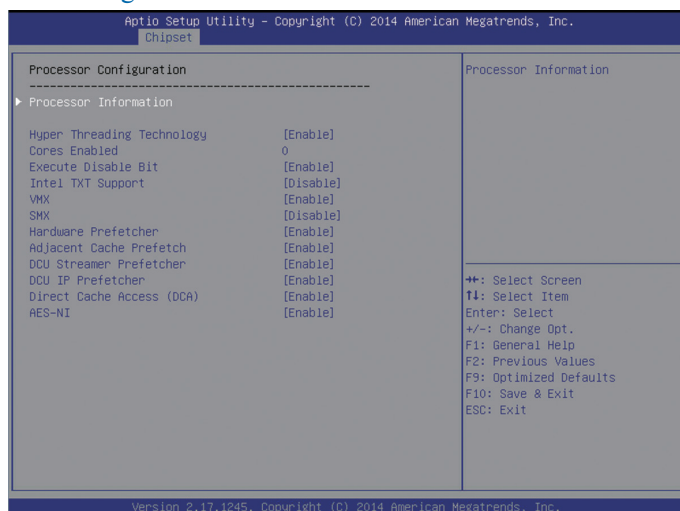

Processor Configuration Menu Interface Instruction Table

Interface Parameters	Function Description
Processor Information	Processor information sub-menu, and processor detailed information.
Hyper Threading Technology	Hyper threading technology settings
Core Enabled	CPU core number settings
Execute Disable Bit	Virus protecting technology settings
Intel TXT Support	Intel trustable execution technology support settings
VMX	Intel hardware-assisted virtualization technology settings
SMX	Safe mode expansion settings
Hardware Prefetcher	Hardware prefetch settings
Adjacent Cache Prefetch	Adjacent high speed cache prefetch settings
DCU Streamer Prefetcher	DCU Streamer prefetch settings
DCU IP Prefetcher	DCU IP prefetch settings
Direct Cache Access (DCA)	Direct high speed cache access settings
AES-NI	Intel AES-NI advanced encryption standard settings

3.2.3.2 Advanced Power Management Configuration

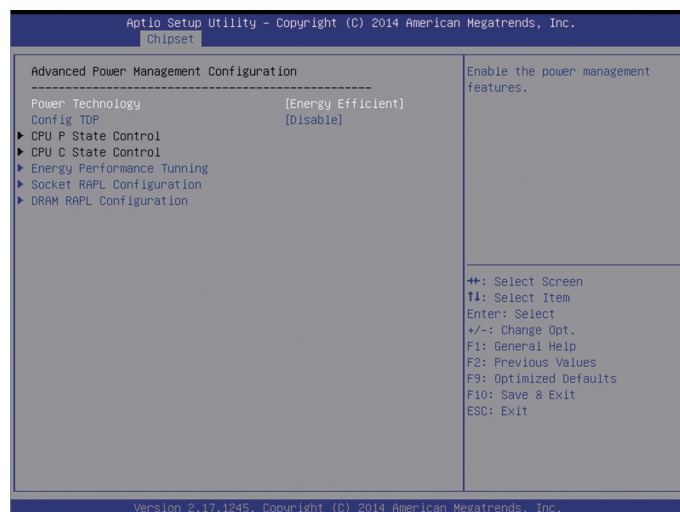

### Advanced Power Management Configuration Menu Interface Instruction Table

Interface Parameters	Function Description
Power Technology	To set power management
Config TDP	TDP settings
CPU P State Control	CPU P State control sets sub-menu, and starts when Power Technology is set to [Custom].
CPU C State Control	CPU C State control sets sub-menu, and starts when Power Technology is set to [Custom].
Energy Performance Tunning	CPU performance and energy tuning sub-menu
Socket RAPL Configuration	Turbo power limit settings sub-menu, and EIST option requires to be set to [Enabled].
DRAM RAPL Configuration	DRAM RAPL configuration sub-menu

#### 1) CPU P State Control

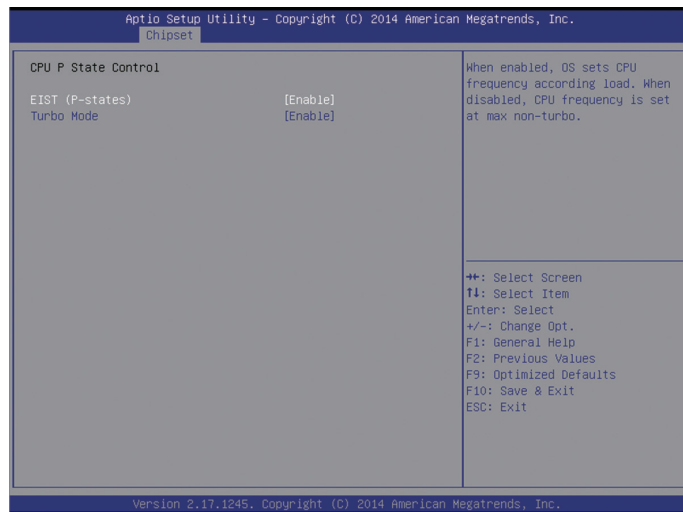

### CPU P State Control Menu Interface Instruction Table

Interface Parameters	Function Description
EIST(P-states)	EIST switching settings
Turbo Mode	Turbo mode switching settings

## 2) CPU C State Control

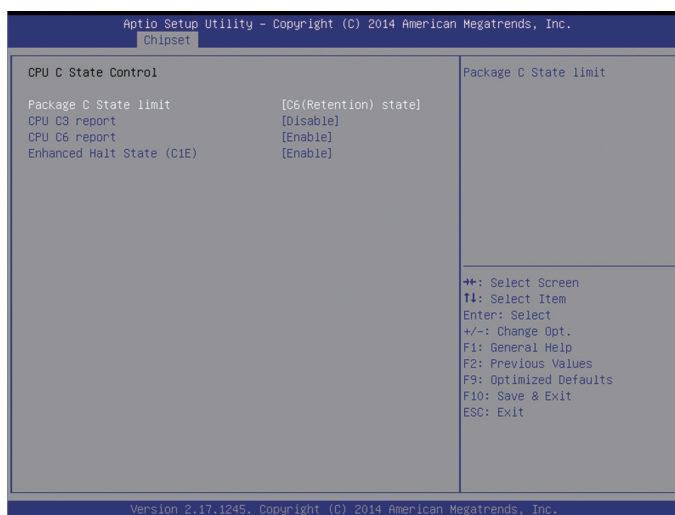

CPU C State Control Menu Interface Instruction Table

Interface Parameters	Function Description
Package C State limit	C state limit settings
CPU C3 report	C3 switching settings
CPU C6 report	C6 switching settings
Enhanced Halt State (C1E)	C1E switching settings

## 3) Energy Performance Tunning

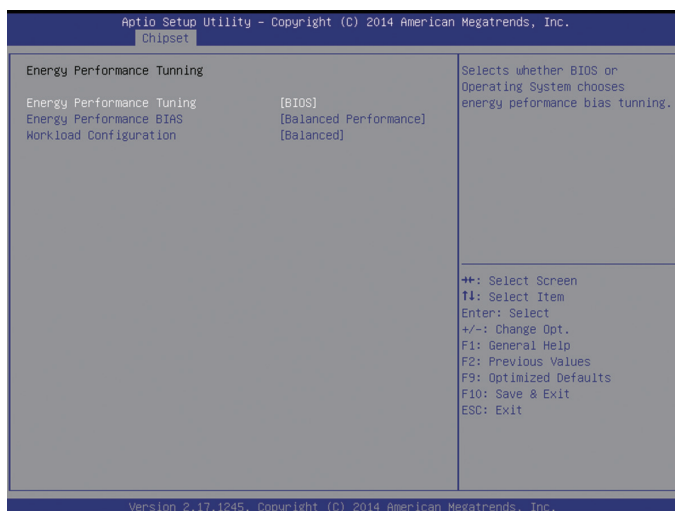

Energy Performance Tunning Menu Interface Instruction Table

Interface Parameters	Function Description
Energy Performance Tunning	To select BIOS or OS to carry out energy performance tuning
Energy PerformanceBIAS	Energy performance management settings
Workload Configuration	Workload configuration



### 3.2.3.3 QPI Configuration

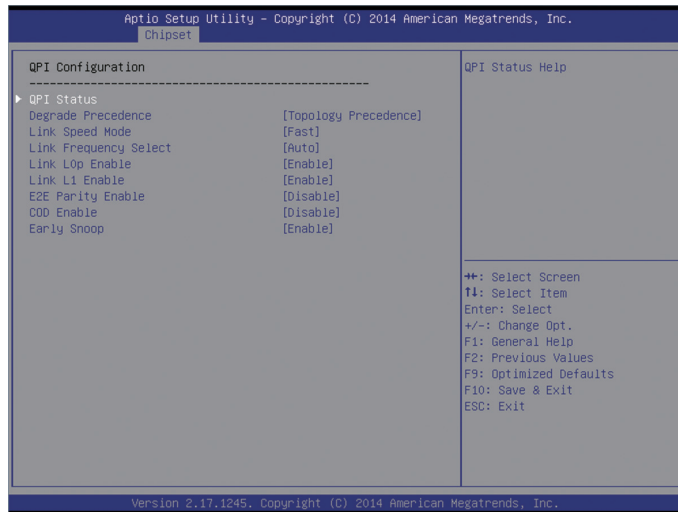

QPI Configuration Menu Interface Instruction Table

Interface Parameters	Function Description
QPI Satus	QPI status display sub-menu
Degrade Precedence	To degrade to priority settings.
Link Speed Mode	Link speed mode settings
Link Frequency Select	Link frequency selection settings
Link L0p Enable	Link power saving mode settings, which is made when bandwidth is half of the peak bandwidth..
Link L1 Enable	In the case that system is extremely idle, turn off QPI Link.
E2E Parity Enable	E2E parity check enabling settings
COD Enable	COD enabling settings
Early Snoop	Early Snoop settings

### 3.2.3.4 Memory Configuration

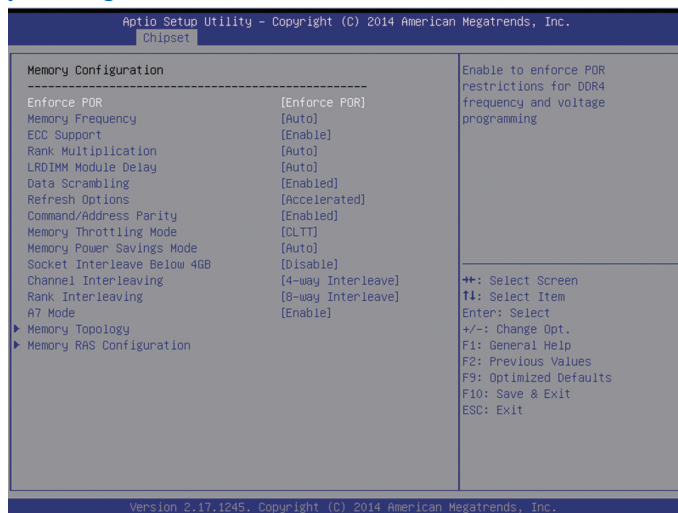

Memory Configuration Menu Interface Instruction Table

Interface Parameters	Function Description
Enforce POR	To execute POR settings
Memory Frequency	Memory frequency settings
ECC Support	ECC support settings
Rank Multiplication	Rank multiplication settings
LRDIMM Module Delay	LRDIMM module delay settings
Data Scrambling	Data scrambling settings
Refresh Options	Refresh mode settings
Command/Address Parity	DDR4 command/address parity check settings
Memory Throttling Mode	Memory thermal throttling mode settings
Memory Power Savings Mode	Memory power saving mode settings
Socket Interleave Below 4GB	Processor Interleaving settings on address space below 4G.
Channel Interleaving	Channel interleaving settings
Rank Interleaving	Rank interleaving settings
A7 Mode	A7 mode settings
Memory Topology	Memory Topology
Memory RAS Configuration	Memory RAS configuration sub-menu

## 1) Memory RAS Configuration

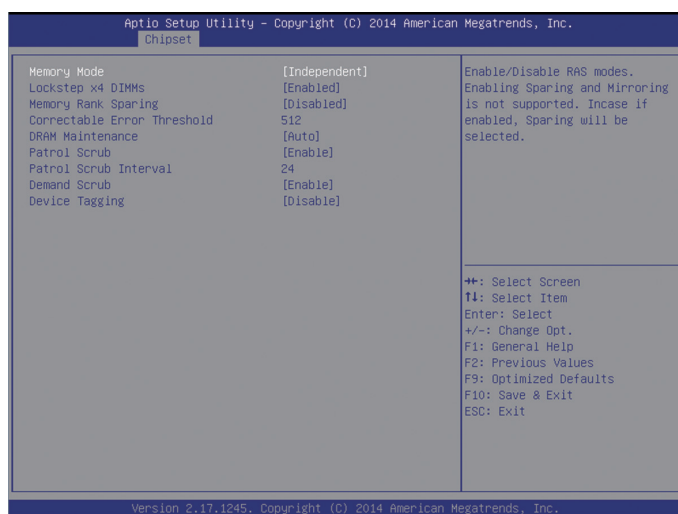

### Memory RAS Configuration Menu Interface Instruction Table

Interface Parameters	Function Description
Memory Mode	As for memory mode configuration, there're 3 options of [Independent], [Mirroring] and [Lock Step].
Lockstep X4 DIMMs	X4 DIMMs' Lockstep switching settings
Memory Rank Sparing	Memory Rank hot sparing settings
Correctable Error Threshold	Correctable error threshold settings
DRAM Maintenance	DRAM maintenance settings
Patrol Scrub	Patrol Scrub settings
Patrol Scrub Interval	Patrol Scrub interleaving settings
Demand Scrub	Demand Scrub settings
Device Tagging	Device tagging settings

### 3.2.3.5 IIO Configuration

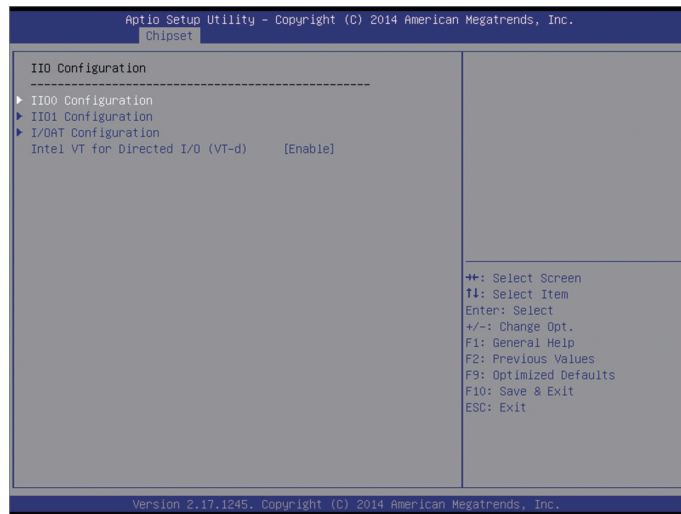

### IIO Configuration Menu Interface Instruction Table

Interface Parameters	Function Description
IIO0 Configuration	IIO0 configuration sub-menu, used to set link speed of PCIE device of CPU0.
IIO1 Configuration	IIO1 configuration sub-menu, used to set link speed of PCIE device of CPU1.
I/OAT Configuration	Intel I/O acceleration technology configuration sub-menu.
Intel VT for Directed I/O (VT-d)	Intel VT-d switching settings

### 3.2.3.6 PCH Configuration

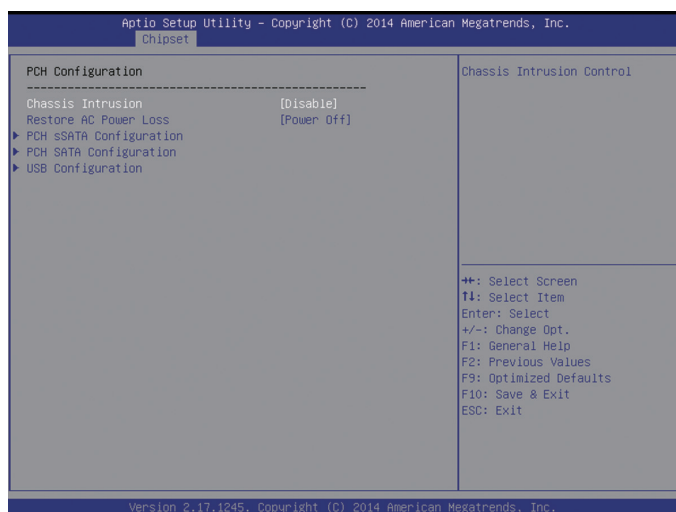

PCH Configuration Menu Interface Instruction Table

Interface Parameters	Function Description
Chassis Intrusion	Chassis intrusion switching settings
Restore AC Power Loss	AC power-on power status settings
PCH sSATA Configuration	PCH sSATA configuration sub-menu
PCH SATA Configuration	PCH SATA configuration sub-menu
USB Configuration	USB configuration sub-menu

#### 1) PCH SATA Configuration

Taking PCH SATA Configuration menu as an example, introduce onboard SATA port, and SATA hard disk configuration, while PCH Ssata Configuration is similar to this, which will not be repeated here.

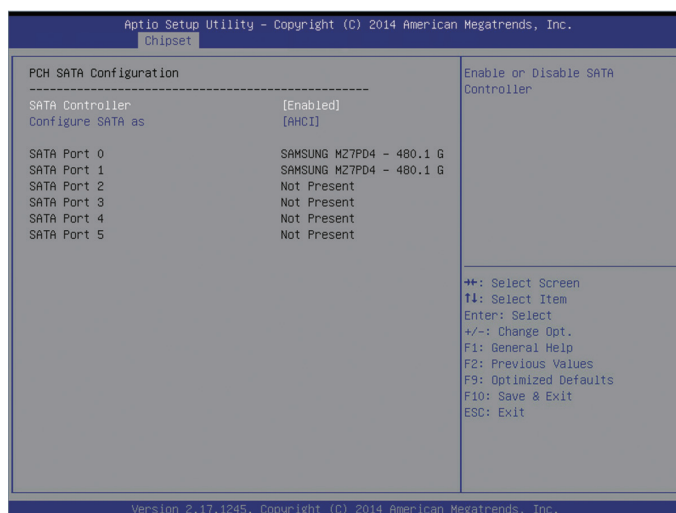

## PCH SATA Configuration Menu Interface Instruction Table

Interface Parameters	Function Description
SATA Controller	SATA controller switching settings
Configure SATA as	As for SATA mode configuration, there're two modes of [AHCI] and [RAID] for setting.
SATA Port 0/1/2/3/4/5	Information of hard disks connected to onboard SATA port 0/1/2/3/4/5.

SATA RAID mode configuration.

a、Configure SATA as an option set to [RAID], press F10 to save settings, and system restarts.

b、During system startup, the following content will display on the screen:

Press<CTRL-I> to enter Configuration Utility...

Meanwhile, press [Ctrl] and [I] synchronously to enter SATA RAID configuration interface, and one example is as shown in the following figure.

```

Intel(R) Rapid Storage Technology enterprise - SATA Option ROM - 4.0.0.1016
Copyright(C) 2003-14 Intel Corporation. All Rights Reserved.

RAID Volumes:
None defined.

Physical Devices:
ID Device Model Serial # Size Type/Status(Vol ID)
0 SAMSUNG MZ7PD480 S15TNYACB00082 447.1GB Non-RAID Disk
1 SAMSUNG MZ7PD480 S15TNYACB00083 447.1GB Non-RAID Disk
Press <CTRL-I> to enter Configuration Utility...
    
```

c、After entering SATA RAID configuration interface, menu list information, information of hard disk connecting to SATA controller (hard disk ID number, hard disk type, hard disk capacity as well as whether hard disk is a volume member etc.), existed RAID volume information (including volume ID number, name, RAID level, capacity, status, whether information bootable) will all display.

```

Intel(R) Rapid Storage Technology enterprise - SATA Option ROM - 4.0.0.1016
Copyright(C) 2003-14 Intel Corporation. All Rights Reserved.

[ MAIN MENU ]
1. Create RAID Volume
2. Delete RAID Volume
3. Reset Disks to Non-RAID
4. Exit

[ DISK/VOLUME INFORMATION ]

RAID Volumes:
None defined.

Physical Devices:
ID Device Model Serial # Size Type/Status(Vol ID)
0 SAMSUNG MZ7PD480 S15TNYACB00082 447.1GB Non-RAID Disk
1 SAMSUNG MZ7PD480 S15TNYACB00083 447.1GB Non-RAID Disk

[F11]-Select [ESC]-Exit [ENTER]-Select Menu
    
```

Press Key	Description
↑↓	Used to move cursor in different menus or to change values of menu options.
TAB	To select the next menu setting option.
Enter	To select a menu.
Esc	To exit menu or return to previous menu from sub-menu.

d、SATA RAID configuration interface has the following 4 executable menus:

Create RAID Volume	To create an RAID volume.
Delete RAID Volume	To delete an existed RAID volume.
Reset Disks to Non-RAID	To reset hard disks in RAID volume, and to restore them to non-RAID status.
Exit	To exit SATA Host RAID configuration interface.

#### a) Create RAID Volume Menu

After entering SATA RAID configuration interface, you could use up and down arrows to select this menu, then press [Enter] to create an RAID volume menu, or directly enter the number before the menu to create an RAID volume menu, for other menu operations are similar, so it will not be repeated here. A Create RAID Volume instance is as shown in the following figure:



System displays the following menu options:

Name	Please enter a volume label name less than 16 characters without containing any special character.
RAID Level	<p>Please select RAID volume level, if no volume has been created at present, there're four volume levels of RAID0(Stripe), RAID1 (Mirror) , RAID10(RAID0+1) and RAID5 (Parity) for selection, please select volume level according to actual requirements.</p> <p>RAID0: This RAID volume is allowed to be made on 2 or above hard disks.  RAID1: This RAID volume is allowed to be made on 2 hard disks.  RAID10: This RAID volume is allowed to be made on 4 hard disks, which is only available when hard disk quantity is 4 or above.  RAID5 (Parity): This RAID volume is allowed to be made on 3 or above hard disks.</p>
Disks	Select hard disks to make RAID volume, press enter after this option is selected, system will enter hard disk selection interface, please select hard disks to make RAID volume using space key accordingly, and then press enter to return to volume create menu.
Strip Size	Please select strip size, only RAID0 and RAID5 volumes could select this option.
Capacity	Set volume capacity, and the default value is the max. volume capacity.

After completing the above configuration, please select [Create Volume], and press enter, system prompts: “WARNING: ALL DATA ON THE SELECTED DISKS WILL BE LOST. Are you sure you want to create this volume?(Y/N):”.

To create an RAID volume, please enter “Y”, a volume will be created, and all data on the selected disk will be lost.

Otherwise, please enter “N”, to exit volume creation.

Here we enter “Y” to create an RAID volume, after creation completed, return to SATA Host RAID configuration main interface, and the created RAID volume will display in RAID volume.

#### b) Delete RAID Volume Menu

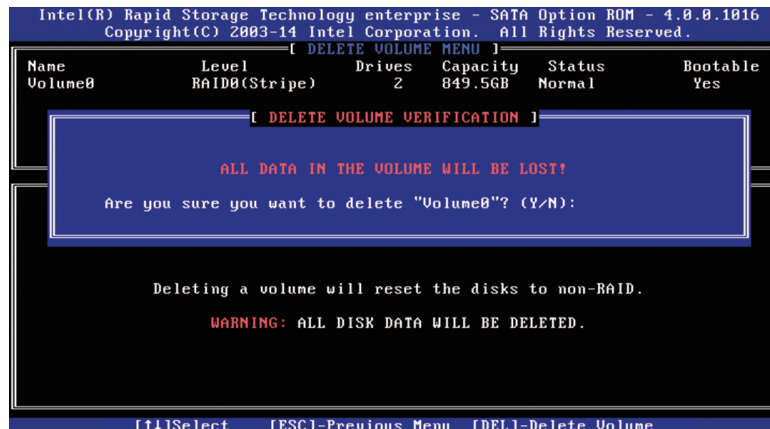

After entering Delete RAID Volume menu, system prompts: “Deleting a volume will reset the disks to non-RAID. Warning: ALL DISKS DATA WILL BE DELETED.”.

To delete an RAID volume, please press [DEL], system prompts: “ALL DATA IN THE VOLUME WILL BE LOST!” again. Are you sure you want to delete “Volume\*”? (Y/N):”, to delete this RAID volume, please enter “Y”, to cancel deletion of this RAID volume, please enter “N”.

### c) Reset Disks to Non-RAID Menu

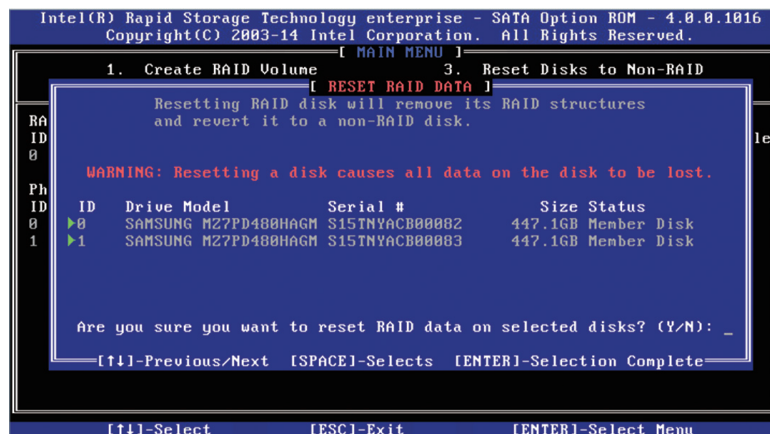

After entering Reset Disks to Non-RAID menu, system will display all hard disks in RAID volume, please select the hard disk to reset using the space key according to actual demand, and then press enter to reset the hard disk, system prompts “Are you sure you want to reset RAID data on selected disks? (Y/N)” again, enter “Y” or “N” according to prompt. It is to be noted that, during resetting hard disk, data on this disk will all be lost, meanwhile, this disk will not belong to RAID volume any more.



d) Exit Menu

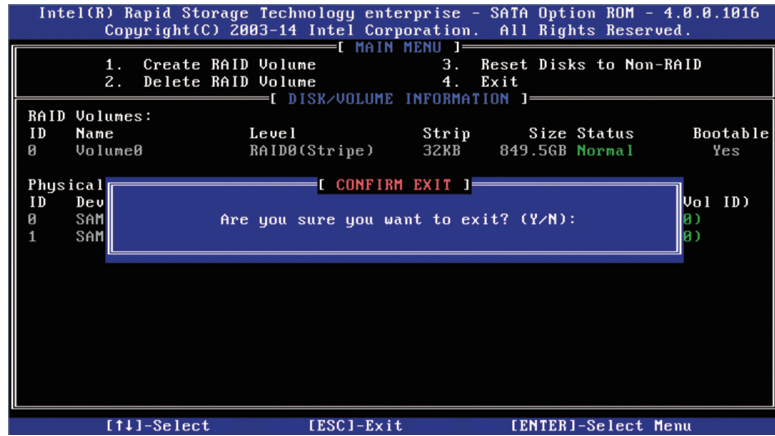

System prompts: " Are you sure you want to exit?(Y/N):", enter "Y", to exit SAS RAID configuration interface, enter "N", to cancel exit operation.

3.2.3.7 Server ME Configuration

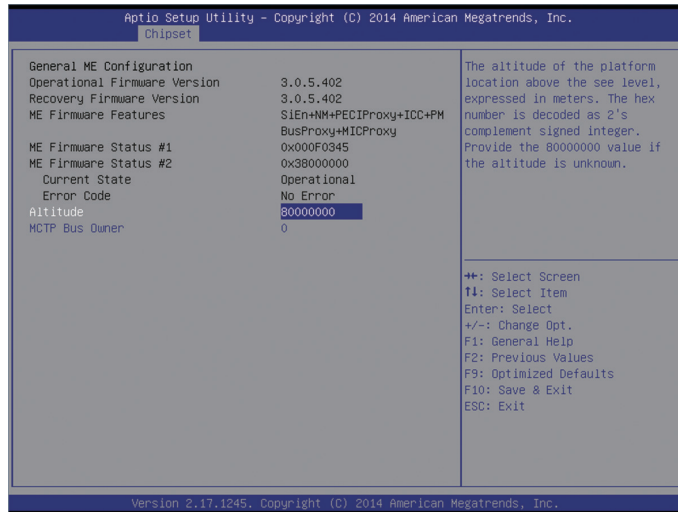

Server ME Configuration Menu Interface Instruction Table

Interface Parameters	Function Description
Operational Firmware Version	Operational ME firmware version
Recovery Firmware Version	Recovery ME firmware version
ME Firmware Features	ME firmware features
ME Firmware Status #1	ME FW status value #1
ME Firmware Status #2	ME FW status value #2
Current State	Current state
Error code	ME FW error code

### 3.2.3.8 Common Configuration

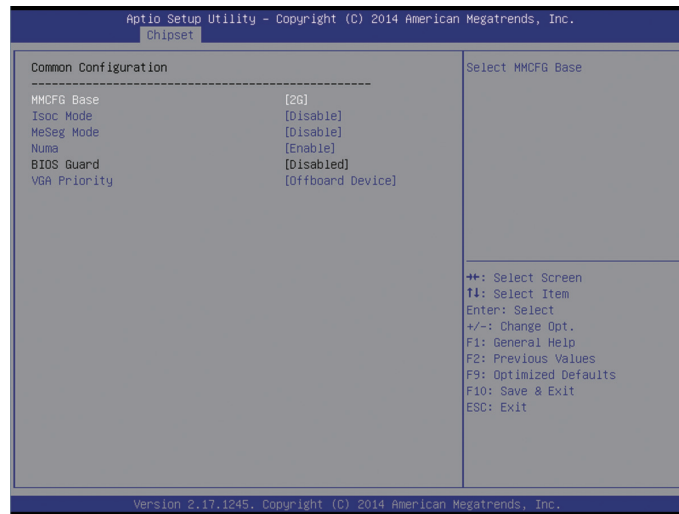

Common Configuration Menu Interface Instruction Table

Interface Parameters	Function Description
MMCFG Base	MMCFG base address settings
Isoc Mode	Isoc mode settings
MeSeg Mode	MeSeg mode settings
Numa	Numa switching settings
BIOS Guard	BIOS guarding settings
VGA Priority	Integrated video card and external video card priority settings.

### 3.2.4 Server Mgmt

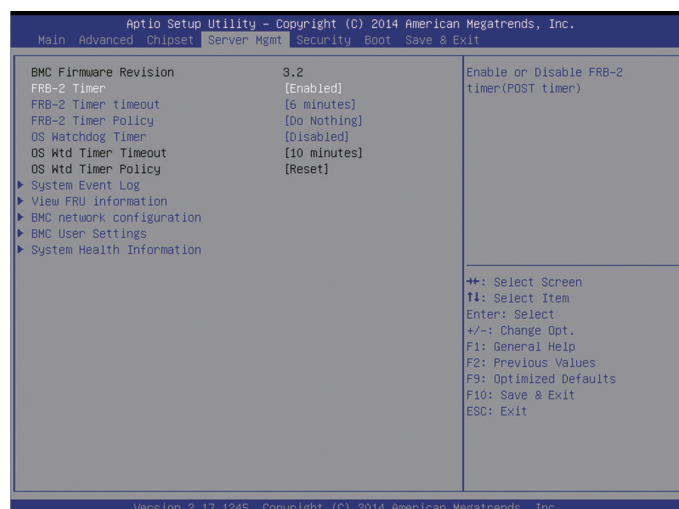

Server Mgmt Menu Interface Instruction Table

Interface Parameters	Function Description
BMC Firmware Version	BMC firmware version
FRB-2 Timer	FRB-2 clock settings
FRB-2 Timer timeout	FRB-2 clock expiration time settings
FRB-2 Timer policy	Policy settings after FRB-2 clock expiration
OS Watchdog Timer	System watchdog clock settings
OS Wtd Timer timeout	OS watchdog clock expiration time settings
OS Wtd Timer policy	Policy settings after OS watchdog clock expiration
BMC network configuration	BMC network settings
System Event Log	System event log sub-menu
View FRU information	To view FRU information sub-menu.
BMC network configuration	BMC network configuration sub-menu
BMC User Settings	BMC user settings sub-menu
SystemHealth Information	System health information sub-menu

### 3.2.4.1 System Event Log

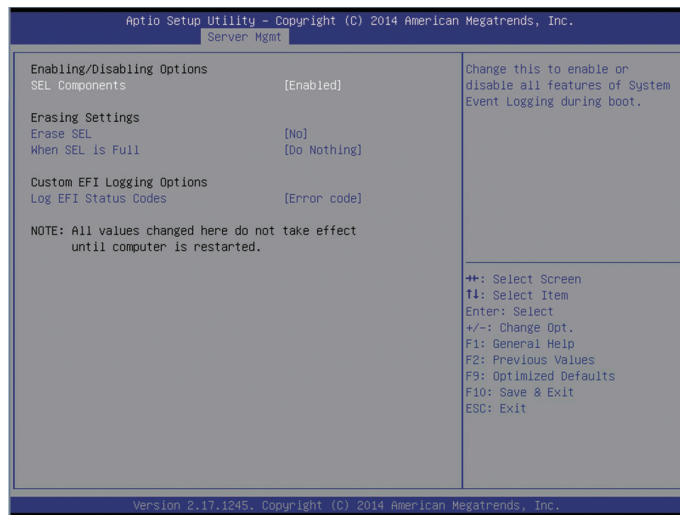

System Event log Menu Interface Instruction Table

Interface Parameters	Function Description
SEL Components	System event log switching settings during startup
Erase SEL	System event log erasing settings
When SEL is Full	Operation settings after system event log is full.
Log EFI Staus Codes	Logging EFI status codes settings

### 3.2.4.2 View FRU Information

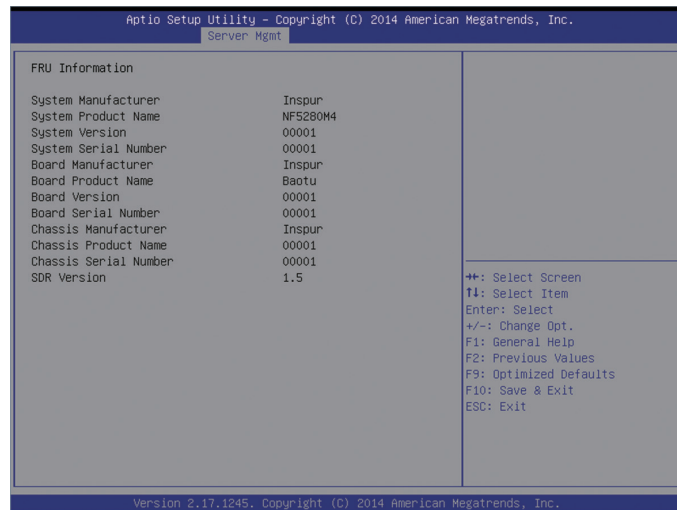

The View FRU Information menu lists BMC FRU information read by BIOS, and BIOS will interact with BMC at each system restart, keeping synchronous update of FRU information.

### 3.2.4.3 BMC network configuration

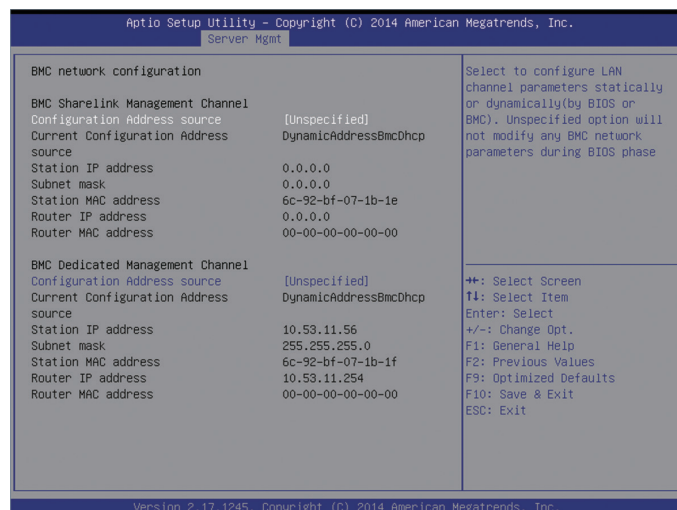

BMC network configuration Menu Interface Instruction Table

Interface Parameters	Function Description
Configuration Address Source	Configuration BMC Network Status Parameter: It could set static IPs, and obtain IPs dynamically, while [Unspecified] will not modify BMC network parameters.
Current Configuration Address	Current configuration address status
Station IP address	Port IP address
Subnet mask	Subnet mask
Station MAC address	Port MAC address
Router IP address	Router IP address
Router MAC address	Router MAC address

BMC network configuration on BIOS setup interface, is to configure BMC management network via BIOS.

1) If no operation is carried out in BIOS, by default, it will read BMC, and configure its Dedicated management port and shareline management port, taking Dedicated management port as an example, the BIOS reading configuration is as shown in the following figure:

```

BMC Dedicated Management Channel
Configuration Address source      [Unspecified]
Current Configuration Address     DynamicAddressBmcDhcp
source
Station IP address                10.53.11.56
Subnet mask                       255.255.255.0
Station MAC address               6c-92-bf-07-1b-1f
Router IP address                 10.53.11.254
Router MAC address                00-00-00-00-00-00
    
```

2) BIOS could carry out Dynamic and Static network settings on BMC Dedicated management port and sharelink management port, taking Dedicated management port as an example, to set a BMC Static IP as follows:

- a、 Set the Configuration Address Source option to [Static]
- b、 Select the Station IP Address option, and press Enter, to pop up the Station IP Address window, enter the Static IP to set manually, after configuration is completed, press Enter to confirm, and an example is as shown in the following figure:

```

BMC Dedicated Management Channel
Configuration Address source
Station IP address      10.53.11.30_
Subnet mask
Station MAC address    6
Router IP address      0.0.0.0
Router MAC address     00-00-00-00-00-00
    
```

c、 Select the Subnet Mask option, and press Enter, to pop up the Subnet Mask box, enter the Subnet Mask to set manually, after configuration is completed, press Enter to confirm, and an example is as shown in the following figure:

```

BMC Dedicated Management Channel
Configuration Address source
Station IP address
Subnet mask            255.255.255.0_
Station MAC address    6c
Router IP address      0.0.0.0
Router MAC address     00-00-00-00-00-00
    
```

d、 Select the Router IP Address option, and press Enter, to pop up the Router IP Address box, enter the Router IP Address to set manually, after configuration is completed, press Enter to confirm, and an example is as shown in the following figure:

```

BMC Dedicated Management Channel
Configuration Address source
Station IP address
Subnet mask
Station MAC address    6
Router IP address      10.53.11.254_
Router MAC address     0.0.0.0
Router MAC address     00-00-00-00-00-00
    
```

e、 When Static IP configuration is done, press F10 to save and restart, BIOS will carry out Static IP configuration for BMC.

```

BMC Dedicated Management Channel
Configuration Address source  [Static]
Station IP address           10.53.11.30
Subnet mask                   255.255.255.0
Station MAC address          6c-92-bf-07-1b-1f
Router IP address            10.53.11.254
Router MAC address           00-00-00-00-00-00
    
```

### 3.2.4.4 BMC User Settings



BMC User Settings Menu Interface Instruction Table

Interface Parameters	Function Description
Add User	The sub-menu for adding users.
Delete User	The sub-menu for deleting users.
Change User Settings	The sub-menu for modify user settings.

#### 1) Add User operation

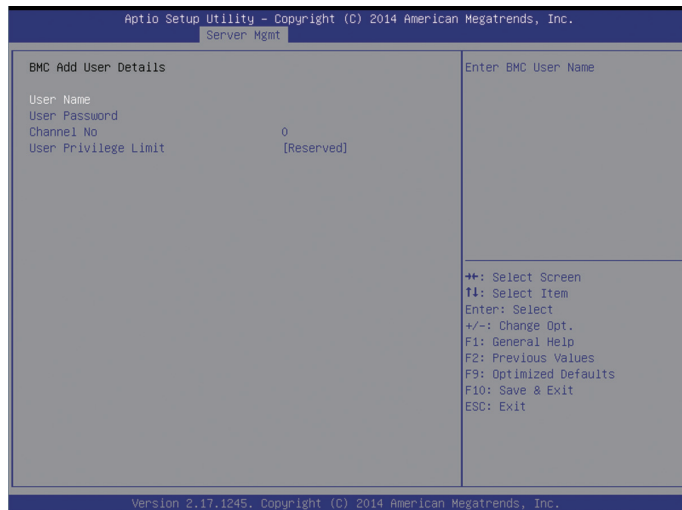

- a、 Select the User Name option, and press Enter to pop up the User Name box, enter the user name to set manually, after configuration is completed, press Enter to confirm.
- b、 Select the User Password option, and press Enter to pop up the User Password box,

enter the user password to set manually, after configuration is completed, press Enter to confirm.

c、Channel NO is set to 1 or 8.

d、The User Privilege Limit option, sets privilege for new user, after configuration is completed, press Enter, to pop up the BMC USER SETTINGS INFO box, when system prompts “Set User Access Command Passed”, press Enter and then OK to confirm, the new user is added successfully, and the example is as shown in the following figure:

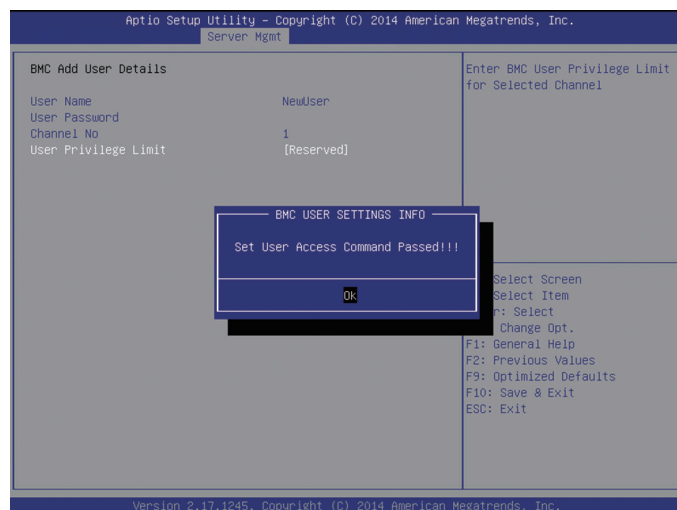

## 2) Delete User operation

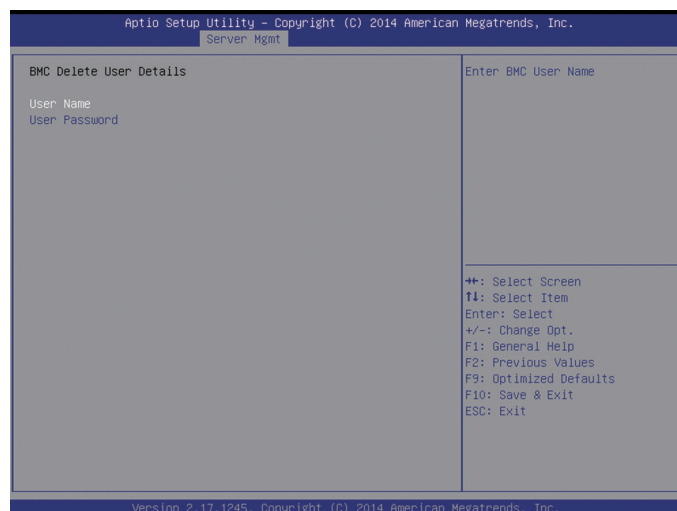

a、Select the User Name option, and press Enter to pop up the User Name box, manually enter the user name to delete, after configuration is completed, press Enter to confirm.



b、 Select the User Password option, and press Enter to pop up the User Password box, manually enter the user password to delete, after that, press Enter to confirm, and the BMC USER SETTINGS INFO prompt will pop up, indicating user password deletion is done or not.

### 3) Change User Settings

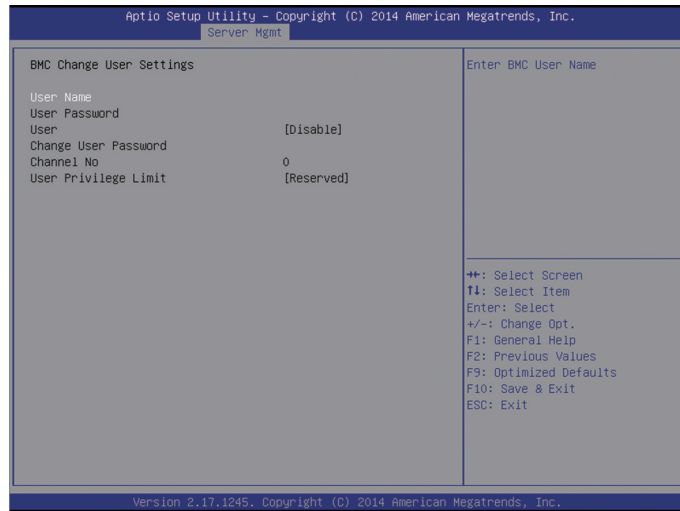

a、 Select the User Name option, and press Enter to pop up the User Name box, manually enter the user name to modify, after configuration is completed, press Enter to confirm.

b、 Select the User Password option, and press Enter to pop up the User Password box, manually enter the user password, and press Enter to confirm.

c、 Select the User option, and set to [Enable] or [Disable].

d、 Select the Change User Password option, to change user password.

e、 Channel NO is set to 1 or 8.

f、 The User Privilege Limit option, could change user’s privilege, after configuration is completed, press Enter, to pop up the BMC USER SETTINGS INFO prompt, when system prompts “Set User Access Command Passed”, press Enter and then OK to confirm, the user settings information is changed successfully.

### 3.2.4.5 System Health Information



System Health Information Menu Interface Instruction Table

Interface Parameters	Function Description
System Temperature Information	System temperature information sub-menu
System Fan Speed	System fan speed sub-menu
System Voltage Information	System voltage information sub-menu

#### 1) System Temperature Information

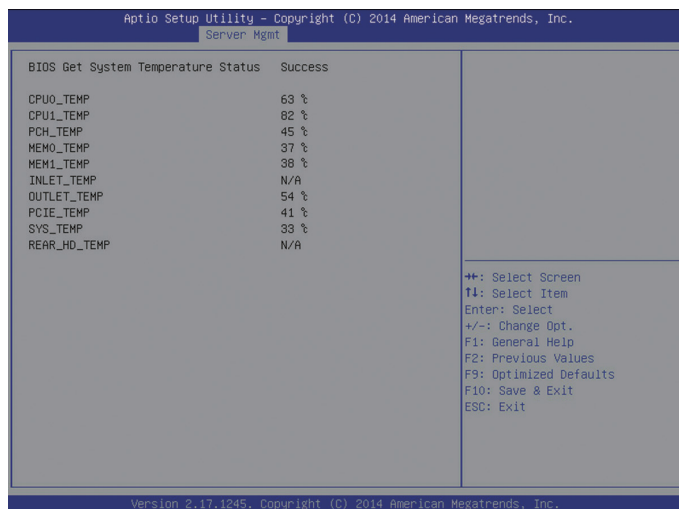

## 2) System Fan Speed

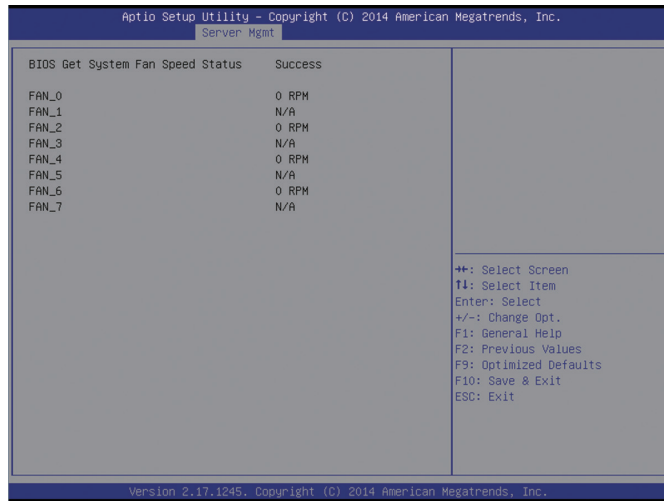

## 3) System Voltage Information

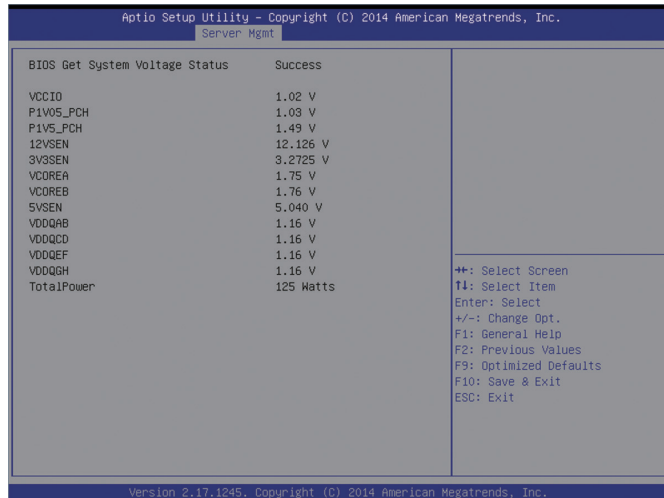

## 3.2.5 Security Menu

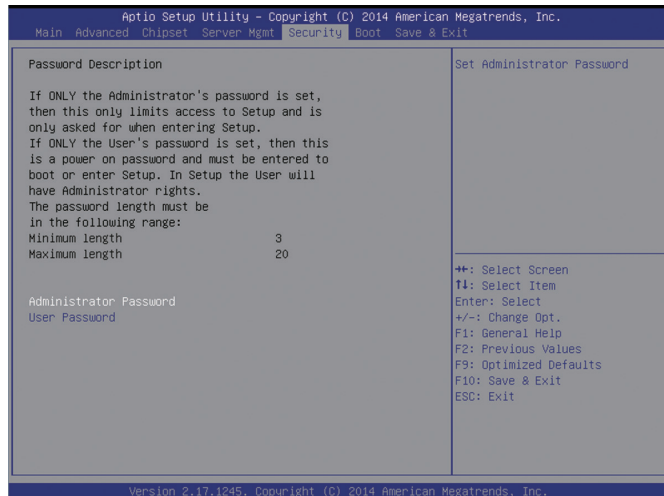

Security Menu Interface Instruction Table

Interface Parameters	Function Description
Administrator Password	Create a password for administrator.
User Password	Create a password for normal user.

### 3.2.6 Boot Menu

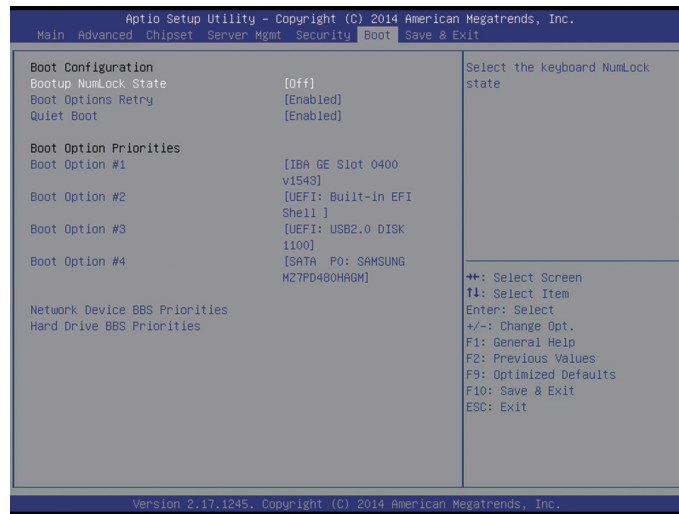

Boot configuration Menu Interface Instruction Table

Interface Parameters	Function Description
Bootup NumLock State	Numlock keys status settings after bootup.
Boot Options Retry	The booting device polling settings
Quiet Boot	To boot quietly, set this option to Enabled, and boot logo displays as that set by manufacturer, disabled, boot logo displays as AMI's default logo.
Boot Option Priorities Boot Option #X	Boot option priority settings
Hard Driver BBS Priorities	Hard disk device BBS priority settings
Network Device BBS Priorities	Network device BBS priority settings

To set BIOS boot operation:

Enter Boot menu, move the cursor to Boot option #X via up and down arrows to select, and set system boot sequence, with X set to 1, 2, 3 etc., while an example is as shown in the following figure:

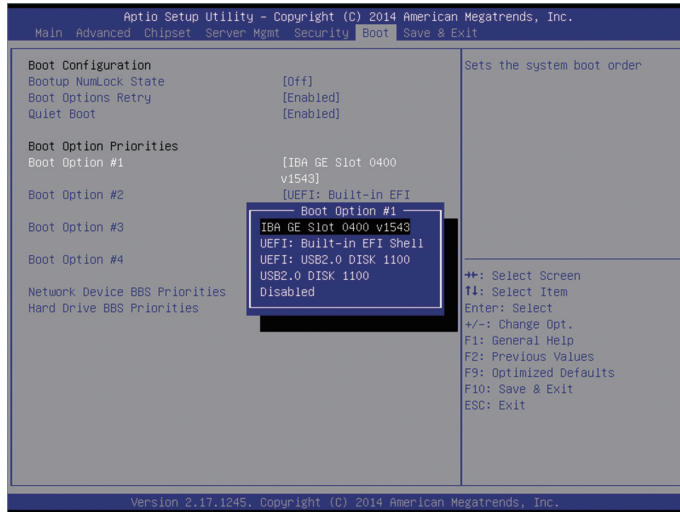

Taking Boot option #1 as an example, you could set the first boot device for the system: Move the cursor to Boot option #1, and press Enter, to pop up the boot option for selection: i.e. IBA GE slot 0400 v1543, UEFI: Built-in EFI Shell, UEFI:USB2.O DISK 1100, USB2.O DISK 1100 etc., select one via up and down keys, i.e. USB2.O DISK 1100, and press Enter, to select USB DOS disk as the first boot device for the system.

### 3.2.7 Save & Exit Menu

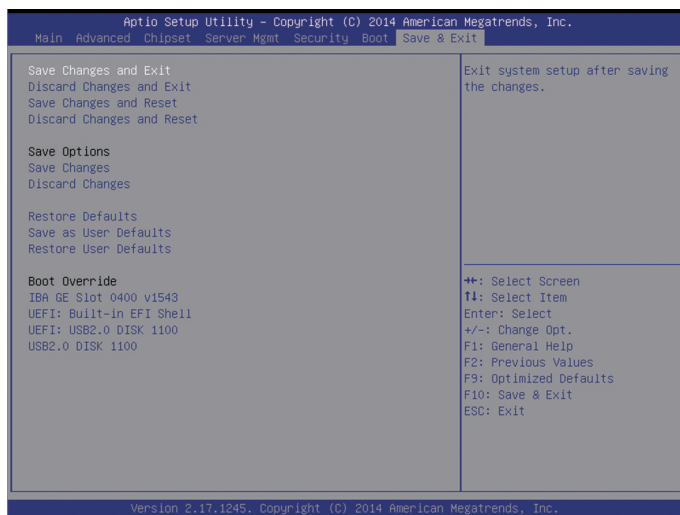

Save &amp; Exit Menu Menu Interface Instruction Table

Interface Parameters	Function Description
Save Changes and Exit	To Save and exit
Discard Changes and Exit	To abandon changes and exit.
Save Changes and Reset	To save changes and reboot
Discard Changes and Reset	To abandon changes and reboot
Save Changes	To save changes.
Discard Changes	To abandon changes.
Restore Defaults	To restore factory settings.
Save as user Defaults	To save as defaults.
Restore user Defaults	To restore user defaults.
Boot Override	To reload boot device, you could select all boot devices in the following.

### 3.3 Firmware Update

For BIOS update, you could select to update in DOS or OS.

#### 1) Use afudos tool to update BIOS in DOS

System boots from USB DOS startup disk, enters the directory containing afudos tool, while bin files of the corresponding new BIOS version have been put into this folder, execute command: afudos BIOS.bin /b /p /n /x /me to update BIOS and ME, for BIOS.bin – bin files of the new BIOS version, an example is as shown in the following figure:

```
C:\AFUDOS>afudos BIOS.bin /b /p /n /x /me
-----
                AMI Firmware Update Utility  v5.06.00
                Copyright (C)2014 American Megatrends Inc. All Rights Reserved.
-----
Reading flash ..... done
- ME Data Size checking . ok
Secure Flash enabled, recalculate ROM size with signature...
- FFS checksums ..... ok
Loading capsule to secure memory buffer ... done
Erasing Boot Block ..... done
Updating Boot Block ..... done
Verifying Boot Block ..... done
Erasing Main Block ..... done
Updating Main Block ..... done
Verifying Main Block ..... done
Erasing NVRAM Block ..... done
Updating NVRAM Block ..... done
Verifying NVRAM Block ..... done
- Update success for /FDT!!
- Successful Update Recovery Loader to OPRx!!
- Successful Update FPT, MFSB, FTFR and MFS!!
- ME Entire Image update success !!
WARNING : System must power-off to have the changes take effect!
```

When there's no change in ME part, to update BIOS part, it is only required to execute command: afudos BIOS.bin /b /p /n /x.

Parameter instructions: /b -- Program Boot Block

/p -- Program Main BIOS

/n -- Program NVRAM

/x -- Don't Check ROM ID

/me -- Program ME Entire Firmware Block

2) Use afudos tool to update BIOS in Linux OS

There're 32bit and 64bit Linux OS afulnx tools, taking Linux 64bit OS as an example, use afulnx\_64 tool, to enter the directory containing afulnx\_64 tool, meanwhile, put bin files of corresponding BIOS into this folder, and enter command: /afulnx\_64 BIOS.BIN /P /B /N / X /R, while an example is as shown in the following figure:

```

root@localhost afulnx64# ./afulnx_64 BIOS.bin /b /p /n /x
-----
          AMI Firmware Update Utility  v5.06.01
          Copyright (C)2014 American Megatrends Inc. All Rights Reserved.
-----
Reading flash ..... done
- ME Data Size checking . ok
Secure Flash enabled, recalculate ROM size with signature...
- FFS checksums ..... ok
Loading capsule to secure memory buffer ... done
Erasing Boot Block ..... done
Updating Boot Block ..... done
Verifying Boot Block ..... done
Erasing Main Block ..... done
Updating Main Block ..... done
Verifying Main Block ..... done
Erasing NVRAM Block ..... done
Updating NVRAM Block ..... done
Verifying NVRAM Block ..... done
  
```

When there's any change in ME part, to update BIOS part, it is required to execute command: afudos BIOS.bin /b /p /n /x /me, with parameter instructions identical to DOS.

3) Use afuWin tool to update BIOS in Windows OS

There're 32bit and 64bit Windows OS afuwin tools, and afuwinx64.exe is used in 64bit OS, run a command prompt, to enter the directory containing afuwinx64.exe tool, meanwhile, put bin files of corresponding BIOS into this folder, and enter command: afuwinx64.exe BIOS.BIN /P /B /N /X /R, to update BIOS files.

Meanwhile, GUI method is provided in Windows to refresh BIOS. Taking Windows 2008R2 OS as an example, use AFUWINGUI tool to update BIOS.

a、 Run AUWINGUI.EXE tool, as shown in the following figure:

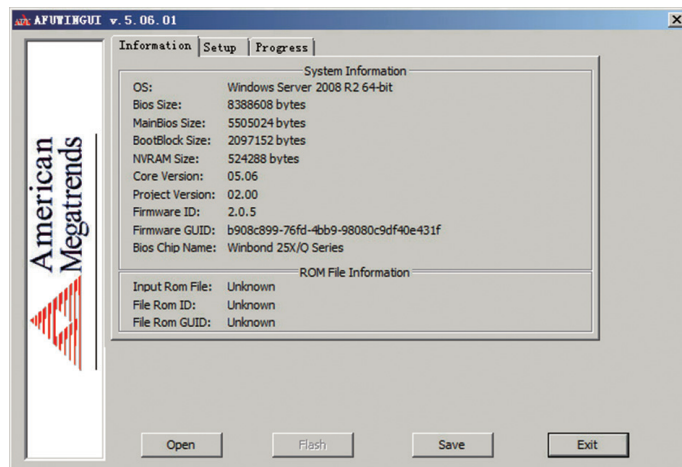

b、 Click the Open button, after selecting the BIOS.bin file to update, system enters Setup interface automatically.

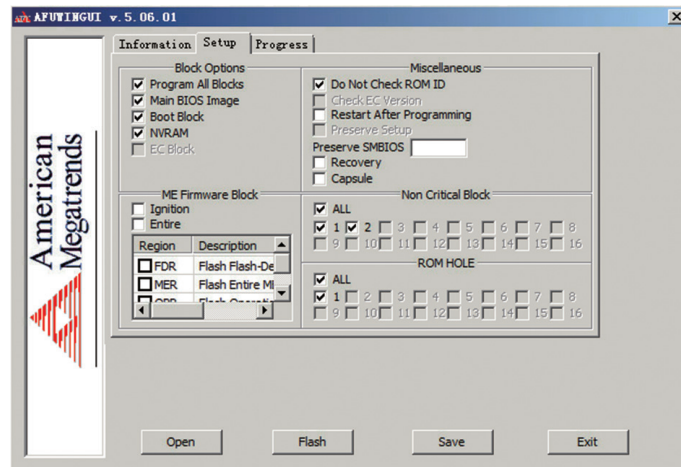

c、 Select Program all Blocks and Do Not Check ROM ID options on Setup interface, click flash button, system enters Progress interface automatically, and executes BIOS update accordingly according to colors shown on the right, thus BIOS update is done as shown in the following figure:

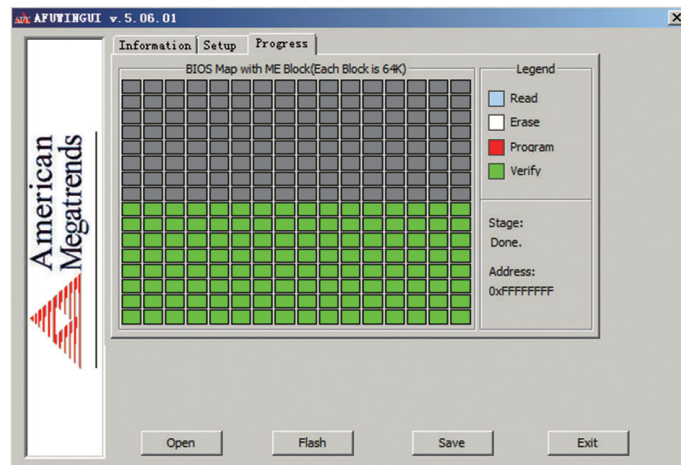



## 4 BMC Configuration

### 4.1 Introduction

This chapter introduces specifications and main functions to be abided by management software.

The distributor server management software is a control unit realizing server management, which is compatible with management standard of the server industry IPMI2.0 specification.

It mainly realizes the following functions:

- Remote control:

It realizes server control via functions such as KVM (Keyboard Video and Mouse) , SOL (Serial Over Lan) and virtual media etc.



Note: SOL function has to be realized via third party tools such as IPMITool etc.

---

- Alarming management

Reports alarming information in a real-time way, and carries out corresponding solutions according to information.

- Status monitoring

Monitors various running states of all monitoring units in a real-time way.

- Device information management

Provides device version information, type and asset information.

- Heat radiation control

It could adjust fan rotation rate according to ambient temperature and workload dynamically.

- Supports IPMITool tool management.

Supports operation according to commands sent by IPMITool, and you could download IPMITool by yourself.



Note: IPMITool downloading website: <http://ipmitool.sourceforge.net/manpage.html>

---

- Supports WEB interface management

Provides a friendly and visual interface management, and you could complete tasks of configuration and query via a click on the interface quickly.

- Supports account centralized management

Supports to store accounts in Active Directory server, and direct certification to server, so as to realize management system login with domain accounts.

## 4.2 Functional Modules

This chapter introduces The distributor server management system module composition as well as functions of these modules.

### 4.2.1 Module Composition

The distributor server management system is mainly composed of IPMI module, command line module, WEB module, KVMOver IP and virtual media etc.

- Command module realizes the calling of IPMI module. User realizes the operation on IPMI module via command lines.
- WEB module realizes daily management on server in the form of visual interface via calling IPMI commands, and WEB module has integrated functions of KVM and virtual media.

### 4.2.2 IPMI Module Introduction

IPMI module realizes management on server system according to IPMI2.0 standard.

Functions realized by IPMI module include:

- System real-time monitoring

It could realize alarming report, alarming indication and self-protection of startup system, when there's any fault detected.

- System remote control

It could realize management requirements such as remote power-on/off, and business system reset etc. via command lines and Web.

### 4.2.3 Command Line Function Introduction

Command line module includes query and configuration commands for network, sensor, fan, user management, system and server etc.

## 4.2.4 Remote Control Module Introduction

Remote control module includes:

- KVM Over IP: It means a management method that user carries out monitoring and control on remote devices via using local video, keyboard and mouse at client, to operate remote devices in a real-time way.
- Virtual media: A method of providing remote access on local media (CD-Rom, floppy drive or CD/floppy disk iso file) in the form of virtual CD driver and floppy drive on server via internet.

To use the remote control function, the Client needs to be equipped with browser of corresponding version and Java runtime environment, as shown in the following table. (The table is to be supplemented)

Instructions:

If Java runtime environment does not comply with requirements, user could login <http://www.oracle.com/technetwork/java/javase/downloads/index.html> to download.

## 4.3 Web Interface Introduction

About this chapter

It introduces Web interface of management system as well as operation steps to login Web interface.

- Login Web interface.  
Introduces methods to login Web interface.
- Web interface introduction  
Introduces Web interface layout.

### 4.3.1 Login Web Interface

It introduces methods to login Web interface.

This guide introduces operation steps to login Web management interface, taking Windows 7 operation system and FireFox browser as examples.



**Note:** When carrying out interface operation via Web, up to 20 users could login synchronously.

---

Step 1 Ensure management net ports on Client and server are connected to internet.

Step 2 Open the browser, and enter “http://ipaddress” in the address bar. (In which ipaddress is the IP address of management port, for specific determining method on IP address, please refer to the annex to determine IP address of management network port)

Step 3 The login interface pops up, as shown in the following figure, in this interface:

1. Enter user name and password.

Note: System provides a default user “admin” in administer user group, and the default password is “admin”.

2. Click “Login”, to enter the management interface.

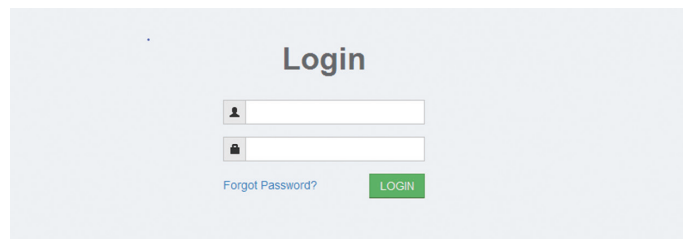

### 4.3.2 Web Interface Introduction

The Web interface helps users to accomplish server management via its visual and friendly interface, and the Web interface contains online help, so users could query instructions and operation guide on this interface via clicking button  on any interface.

Web interface is divided into four parts, as shown in the following figure.

The screenshot displays the BMC Web Interface with a sidebar on the left containing navigation options: System Information, Remote Control, Power and Fan, BMC Settings, Logs, Fault Diagnosis, and System Maintenance. The main content area is titled 'General Information' and is divided into several sections:

- System Running State:** Includes Current Power Status, CPU, Memory, Fan, Power Supply Units, and Chassis Intrusion (Chassis is opened).
- BMC Information:** Shows LAN Interface (Shared/Dedicated), MAC Address (KC:92:BF:0C:01:2B), Network Mode (DHCP), IPv4 Address (10.52.111.239), Web Session Timeout (1800s), Web Active Users (3/20), and Server Running Time (0 Days, 0 Hours).
- Server Information:** Lists Chassis Type (Rack Mount Chassis), Product Name (NF5280M4), Manufacture Name (Inspur), Product Serial Number (0), and Asset Tag (NULL).
- FW Version Information:** A table listing various firmware versions such as BIOS, ME, PSU, PSU1, CPU1 VR, CPU1 VR Revision, DDR\_AB VR, DDR\_CD VR, DDR\_EF VR, DDR\_GH VR, FPGAD, and MCU.
- Quick Launch Tasks:** A grid of icons for Console Redirection, Power Control, Users, Network, Hardware Monitor, and Firmware Update.
- Recent System Event Log:** A table with columns for Event ID, Time Stamp, Severity, Sensor Name, and Description. It lists several events related to system restarts, chassis intrusions, and drive presence detections.

A legend at the bottom identifies event severities: Normal (green circle), Information (blue circle), Warning (yellow triangle), Critical (red circle), Power On/Presence (blue square), Power Off/Absent/NA (grey square), and Not Support (grey circle). The footer indicates the version is 62015.

- The name of Web interface is displayed on top left of the interface.

- Meanings of all buttons on top right of the interface:



Click the System Abstract button, to return to the System Abstract page.



Click the Refresh button, to refresh the page.



Click the Language button, to shift language, which supports Chinese and English.



Click the Help button to query help information on corresponding page.



Click the Logout button, to return to login page.

- There's a navigation tree on the left, via nodes on the tree, you could select different functional interfaces. Functions able to be realized via Web interface include: Viewing the overall situation, viewing system information, remote control, power management, event and log query, real-time monitoring, diagnosis and orientation, system maintenance, and system configuration etc. For detailed introduction on all functions, please refer to the following chapters.

- Specific operation interface is on the right of the interface.

### 4.3.3 Overall Situation

Click System Abstract, to open the “System Abstract” interface, as shown in the following figure.

The screenshot displays the 'General Information' page of the System Abstract interface. It is organized into several sections:

- System Running State:** A table showing the status of various components:
 

Current Power Status	<span style="color: green;">●</span> (More)
CPU	<span style="color: green;">●</span> (More)
Memory	<span style="color: green;">●</span> (More)
Fan	<span style="color: green;">●</span> (More)
Power Supply Units	<span style="color: green;">●</span> (More)
Chassis Intrusion	<span style="color: orange;">▲</span> (Chassis is opened)
- Quick Launch Tasks:** A grid of six buttons: Console Redirection, Power Control, Users, Network, Hardware Monitor, and Firmware Update.
- BMC Information:** Network settings including LAN interface (Shared/Dedicated), MAC address (0C:62:BF:0C:01:2B), Network Mode (DHCP), IPv4 Address (10.52.11.239), Web Session Timeout (1800s), Web Active Users (3/20), and Server Running Time (1 Days, 2 Hours).
- Server Information:** Chassis Type (Rack Mount Chassis), Product Name (NFS280M4), Manufacture Name (inspur), Product Serial Number (0), and Asset Tag (NULL).
- FW Version Information:** A table listing various firmware and BIOS versions:
 

Firmware Revision	4.4.0(Nov 14 2014 16:33:33 CST)
BIOS Revision	4.0.0(12/25/2014)
ME Revision	3.0.7.141
PSU0 Revision	1.030
PSU1 Revision	N/A
CPU0 VR Revision	00
CPU1 VR Revision	00
DDR_AB VR Revision	00
DDR_CD VR Revision	00
DDR_EF VR Revision	00
DDR_GH VR Revision	00
FPGA0 Revision	1.0
MCU Revision	3.0.0
- Recent System Event Log:** A table with columns for Event ID, Time Stamp, Severity, Sensor Name, and Description.
 

Event ID	Time Stamp	Severity	Sensor Name	Description
81	01/07/2015 01:15:14	<span style="color: blue;">●</span>	Other	Boot Completed - Boot Device Not Specified - Asserted
80	01/07/2015 06:18:17	<span style="color: blue;">●</span>	Other	System Restart - Asserted
79	01/07/2015 06:17:14	<span style="color: blue;">●</span>	HDD_Status	Drive Presence - Asserted
78	01/07/2015 06:17:14	<span style="color: blue;">●</span>	PSU0_Supply	Presence Detected - Asserted
77	01/07/2015 06:17:12	<span style="color: blue;">●</span>	HDD_Status	Drive Presence - Asserted
76	01/07/2015 06:17:12	<span style="color: blue;">●</span>	HDD_Status	Drive Presence - Asserted
75	01/07/2015 06:17:12	<span style="color: blue;">●</span>	Power_Status	Legacy ON State - Asserted
74	01/07/2015 06:17:12	<span style="color: blue;">●</span>	Power Button	Power Button Pressed - Asserted
73	Pre-init Timestamp	<span style="color: blue;">●</span>	Intrusion	General Chassis Intrusion - Asserted
72	Pre-init Timestamp	<span style="color: blue;">●</span>	Power Status	Legacy OFF State - Asserted

A legend at the bottom explains the severity icons: Normal (blue dot), Information (green dot), Warning (orange triangle), Critical (red square), Power On/Present (green circle), Power Off/Absent/NA (grey circle), and Not Support (grey square).

### 4.3.4 System Information

Select “System Information” on navigation tree, which includes five interfaces of “Asset Information”, “Hardware Monitoring”, “Device Status”, “BIOS Option”, “FRU Information”, as shown in the following figure.

- Asset information: Displays system configuration information, which includes CPU, memory, PCIE device and Mac address information.
- Hardware monitoring: Displays real-time monitoring information, which includes temperature sensor, voltage sensor, fan rotation rate, power, processor status, memory status and power module status information.
- Device status: Displays status information of the front set hard disk.
- FRU information: Displays FRU information;

**Asset information**

CPU Memory PCIE Onboard NIC Power Supply Unit

Number of Present Devices: 2

No.	Present	Model	Used Core	Thermal Design Power(W)	L1 Cache(KB)	L2 Cache(KB)	L3 Cache(KB)
CPU_0	●	Intel(R) Xeon(R) CPU E5-2680 v3 @ 2.50GHz	12/12	120	768	3072	30720
CPU_1	●	Intel(R) Xeon(R) CPU E5-2680 v3 @ 2.50GHz	12/12	120	768	3072	30720

**Hardware Monitor**

Temperature Voltage Fan Power Supply Processor Memory Power Unit Drive Slot (Bay) Event Logging disabled

Management Subsystem Health

Sensor	Status	Reading	Low NCT	Low CT	Low NRT	Up NCT	Up CT	Up NRT
CPU0_Temp	●	35°C	N/A	N/A	N/A	102°C	112°C	N/A
CPU1_Temp	●	34°C	N/A	N/A	N/A	102°C	112°C	N/A
FCH_Temp	●	36°C	N/A	N/A	N/A	100°C	110°C	N/A
DIMMG0_Temp	●	30°C	N/A	N/A	N/A	95°C	105°C	N/A
DIMMG1_Temp	●	31°C	N/A	N/A	N/A	95°C	105°C	N/A
Inlet_Temp	●	N/A	N/A	N/A	N/A	40°C	50°C	N/A
Outlet_Temp	●	38°C	N/A	N/A	N/A	N/A	N/A	N/A
SYS0_Temp	●	31°C	N/A	N/A	N/A	N/A	N/A	N/A
SYS1_Temp	●	28°C	N/A	N/A	N/A	N/A	N/A	N/A
HDD0_REAR_Temp	●	N/A	N/A	N/A	N/A	60°C	70°C	N/A
HDD1_REAR_Temp	●	N/A	N/A	N/A	N/A	60°C	70°C	N/A
RISER0_Temp	●	31°C	N/A	N/A	N/A	N/A	N/A	N/A
RISER1_Temp	●	N/A	N/A	N/A	N/A	N/A	N/A	N/A
GPU0_Temp	●	N/A	N/A	N/A	N/A	82°C	92°C	N/A
GPU1_Temp	●	N/A	N/A	N/A	N/A	82°C	92°C	N/A
MIC0_Temp	●	N/A	N/A	N/A	N/A	104°C	114°C	N/A
MIC1_Temp	●	N/A	N/A	N/A	N/A	104°C	114°C	N/A

**System Device Status**

Front Hard Disk NIC

Onboard Network Card ID	Link Status
NIC0	●
NIC1	●

BIOS Setup Options

Advanced | Chipset | Boot

**Advanced (Host is power off now. We list BIOS setup options with last time.)**

Setup Option	Setup Option Value
COM0 Console Redirection	Disable
Above 4G Decoding	Disable

FRU Information

Basic Information | Chassis Information | Board Information | Product Information

Attribute	Value
FRU Device ID	0
FRU Device Name	BMC_FRU

## 4.4 Remote Control

Select “Remote Control” on navigation tree, to open the remote control interface, which contains six interfaces of “Console Redirection (KVM)”, server switch-on/off control, server orientation, remote session configuration, virtual media configuration and mouse mode configuration, as shown in the following figure.

- **Console redirection (KVM):** To pop up the KVM console window.
- **Server switch-on/off control:** To control startup, shutdown and restart of the server.
- **Server orientation:** To turn on/off the positioning light.
- **Remote session configuration:** To set KVM session encryption, media encryption and virtual media connection methods.
- **Virtual media configuration:** To set the quantity of virtual media (floppy disks, CD drives and hard disks etc.)
- **Mouse mode configuration:** To set the mouse working mode for KVM remote console.

Console Redirection

1. Click 'KVM Over IP' button and download the JNLP file
2. Open the JNLP file through JRE and login to the terminal

Control console redirection

KVM Attributes	
Maximum Sessions	5
Active Sessions	0

## Server Power Control

Server Power Control	
Current Power Status	<input checked="" type="radio"/>
Control Options	<input checked="" type="radio"/> Power On <input type="radio"/> Power Off <input type="radio"/> Force Power Off <input type="radio"/> Warm Reset <input type="radio"/> Power Cycle

## Server Location

Server Location	
System ID LED Status	<input checked="" type="radio"/>
System ID LED Light Time	<input checked="" type="radio"/> All the time <input type="radio"/> 10s <input type="radio"/> 20s <input type="radio"/> 60s <input type="radio"/> Other <input type="text" value=""/> s
System ID LED Operation	<input type="button" value="Turn On Led"/> <input type="button" value="Turn Off Led"/>

## Configure Remote Session

Configure Remote Session	
KVM Encryption	<input type="checkbox"/> Enable
Media Encryption	<input type="checkbox"/> Enable
Virtual Media Attach Mode	Auto Attach <input type="button" value="v"/>

## Virtual Media Devices

Virtual Media Devices	
Floppy devices	1 <input type="button" value="v"/>
CD/DVD devices	1 <input type="button" value="v"/>
Harddisk devices	1 <input type="button" value="v"/>
SD Media Support	<input type="checkbox"/> Enable

## Mouse Mode Settings

Mouse Mode Settings	
Current Mouse Mode	Absolute
Mouse Mode Options	<input type="radio"/> Relative (Recommended for Linux(Except Redhat6) running on Host) <input checked="" type="radio"/> Absolute (Recommended for Windows and Redhat6 running on Host) <input type="radio"/> Other (Recommended for SLES-11 running on Host)

## 4.5 Power Supply and Heat Radiation

Select “Power Supply and Heat Radiation” on navigation tree, to open the power supply and heat radiation page, which contains three pages of power supply monitoring, power supply management, fan rotation rate control, as shown in the following figure.

- Power supply monitoring: Contains power supply module presence status, alarming status, temperature, input power, output power, input voltage, output voltage, input



current, output current and power supply module firmware version information.

- Power supply management: Contains power supply module presence status, current status and primary/secondary mode switching function.
- Fan rotation rate control: Contains fan status, current rotation rate information and rotation rate control function.



Note: Fan rotation rate control contains the following rotation rate gears:

- ★ Low speed gear: About 20% duty ratio.
- ★ Medium speed gear: About 50% duty ratio.
- ★ High speed gear: About 80% duty ratio.
- ★ Full speed gear: 100% duty ratio.

#### Power Supply Units

No.	Present	Alert	Mfr Model	Temp(C)	Pout(W)	Pin(W)	Vin(V)	Vout(V)	FW Version	A/S Switch
PSU0		N/A	N/A	N/A	N/A	N/A	N/A	N/A	N/A	<input type="button" value="N/A"/>
PSU0		N/A	N/A	N/A	N/A	N/A	N/A	N/A	N/A	<input type="button" value="N/A"/>

NOTE: Host is currently power off, we will show more power supply info after power on.

#### Fan Speed Control

Current Thermal Config: Below 8HDD(include 8HDD) + No Rear HDD

Manual Fan Control

No.	Status	Current speed	Speed control			
			Low(20%)	Medium(50%)	High(80%)	Full(100%)
FAN_0		0 (0%)	<input type="button" value="Low(20%)"/>	<input type="button" value="Medium(50%)"/>	<input type="button" value="High(80%)"/>	<input type="button" value="Full(100%)"/>
FAN_1		N/A	<input type="button" value="Low(20%)"/>	<input type="button" value="Medium(50%)"/>	<input type="button" value="High(80%)"/>	<input type="button" value="Full(100%)"/>
FAN_2		0 (0%)	<input type="button" value="Low(20%)"/>	<input type="button" value="Medium(50%)"/>	<input type="button" value="High(80%)"/>	<input type="button" value="Full(100%)"/>
FAN_3		N/A	<input type="button" value="Low(20%)"/>	<input type="button" value="Medium(50%)"/>	<input type="button" value="High(80%)"/>	<input type="button" value="Full(100%)"/>
FAN_4		0 (0%)	<input type="button" value="Low(20%)"/>	<input type="button" value="Medium(50%)"/>	<input type="button" value="High(80%)"/>	<input type="button" value="Full(100%)"/>
FAN_5		N/A	<input type="button" value="Low(20%)"/>	<input type="button" value="Medium(50%)"/>	<input type="button" value="High(80%)"/>	<input type="button" value="Full(100%)"/>
FAN_6		0 (0%)	<input type="button" value="Low(20%)"/>	<input type="button" value="Medium(50%)"/>	<input type="button" value="High(80%)"/>	<input type="button" value="Full(100%)"/>
FAN_7		N/A	<input type="button" value="Low(20%)"/>	<input type="button" value="Medium(50%)"/>	<input type="button" value="High(80%)"/>	<input type="button" value="Full(100%)"/>

## 4.6 BMC Configuration

Select “BMC Configuration” on navigation tree, to open the BMC configuration page, which contains 10 pages of “BMC Network”, “Service Configuration”, “NTP Configuration”, “SMTP Configuration”, “Alarming Management”, “Active Directory Configuration”, “LDAP/E-Directory”, “User Configuration”, “IP Access Control”, “NCSI Network Card Selection”, as shown in the following figure.

- BMC network: Contains network for BMC configuration (static IP and DHCP), DNS configuration and network interface binding function.
- Service configuration: Configures BMC’S Web service, KVM service, ssh service and

telnet service etc.

- NTP configuration: Sets BMC time, which has two methods:
  - ★ One is to synchronize from NTP server.
  - ★ The other is to configure time manually.
- SMTP configuration: Sets SMTP server information related to alarming.
- Alarming management: Sets information about BMC management module alarming event filtering and alarming targets etc.
- Active directory configuration: Carries out related configuration on BMC active directory.
- LDAP/E-Directory: Carries out related configuration on BMC's LDAP.
- User configuration: Carries out management on BMC users, including add user, delete user and change password.
- IP access control: Configures IP address fields accessible to BMC.
- NCSI network card selection: Includes NCSI network card switching, and NCSI work mode switching functions.

**BMC Network Management**

Network DNS Network Interface Bonding

LAN Interface	Shared <input type="button" value="v"/>
LAN Settings	<input checked="" type="checkbox"/> Enable
MAC address	6C:92:BF:0C:01:2B

**IPv4 Configuration**

Obtain an IP address automatically	<input checked="" type="checkbox"/> Enable DHCP
IPv4 Address	10.52.11.239
Subnet Mask	255.255.255.0
Default gateway	10.52.11.254

**VLAN Configuration**

VLAN Setting	<input type="checkbox"/> Enable
VLAN ID	0
VLAN priority	0

**Services**

#	Service Name	Current State	Interfaces	Nonsecure Port	Secure Port	Timeout(s)	Maximum Sessions	Active Sessions
1	web	Active	both	80	443	1800	20	2
2	kvm	Active	both	7578	7582	N/A	5	0
3	cd-media	Active	both	5120	5124	N/A	1	0
4	fd-media	Active	both	5122	5126	N/A	1	0
5	hd-media	Active	both	5123	5127	N/A	1	0
6	ssh	Inactive	N/A	N/A	22	600	N/A	N/A
7	telnet	Inactive	N/A	23	N/A	600	N/A	N/A

### NTP Settings

NTP Settings			
Date:	January	6	2015
Time:	20	24	01 hh.mm.ss
UTC TimeZone:	(GMT+08:00)		
NTP Server:	pool.ntp.org		

Automatically synchronize Date & Time with NTP Server

Refresh Save Reset

### SMTP Settings

LAN Channel	Shared
Sender Email	

Primary SMTP Server	
SMTP Support	<input checked="" type="checkbox"/> Enable
SMTP Server IP Address	
Username	
Password	

Secondary SMTP Server	
SMTP Support	<input checked="" type="checkbox"/> Enable
SMTP Server IP Address	
Username	
Password	

Save Reset

### Alert Settings

SNMP Trap Configure	
Trap Version	v1
Community	public
Username	
Engine ID(Hex)	
Authentication and password	NONE
Privacy and password	NONE
System Name	
System ID	
Host Location	
Contact	
Host OS	

Save Reset

Alert Policy Configure					
No.	Event Filter(Severity/Type/Name)	LAN Channel	Alert Type	Destination	Action
<input type="checkbox"/> 1	All Events / All Sensors / Any	Shared	Trap	0.0.0.0	Save Reset Test
<input type="checkbox"/> 2	All Events / All Sensors / Any	Shared	Trap	0.0.0.0	Save Reset Test
<input type="checkbox"/> 3	All Events / All Sensors / Any	Shared	Trap	0.0.0.0	Save Reset Test

## Active Directory Settings

The 'Active Directory' is currently disabled. To enable Active Directory and configure its settings. Click on 'Advanced Settings' button. [Advanced Settings](#)

The list below shows the current list of configured Role Groups. If you would like to delete or modify a role group, select the name in the list and press Delete Role Group or Modify Role Group. To add a new Role Group, select an unconfigured slot and press Add Role Group.

Role Group ID	Group Name	Group Domain	Group Privilege
1	~	~	~
2	~	~	~
3	~	~	~
4	~	~	~
5	~	~	~

[Add Role Group](#) [Modify Role Group](#) [Delete Role Group](#)

## LDAP/E-Directory Settings

LDAP/E-Directory is currently disabled. To enable LDAP/E-Directory and configure its settings. Click on 'Advanced Settings' button. [Advanced Settings](#)

The list below shows the current list of configured Role Groups. If you would like to delete or modify a role group, select the name in the list and press Delete Role Group or Modify Role Group. To add a new Role Group, select an unconfigured slot and press Add Role Group.

Role Group ID	Group Name	Group Search Base	Group Privilege
1	~	~	~
2	~	~	~
3	~	~	~
4	~	~	~
5	~	~	~

[Add Role Group](#) [Modify Role Group](#) [Delete Role Group](#)

## User Management

Number of configured users: 1

UserID	Username	UserAccess	Network Privilege	SNMP Status	Email ID
1	admin	Enabled	Administrator	Disabled	test@svyf.com
2	~	~	~	~	~
3	~	~	~	~	~
4	~	~	~	~	~
5	~	~	~	~	~
6	~	~	~	~	~
7	~	~	~	~	~
8	~	~	~	~	~
9	~	~	~	~	~
10	~	~	~	~	~
11	~	~	~	~	~
12	~	~	~	~	~
13	~	~	~	~	~
14	~	~	~	~	~
15	~	~	~	~	~
16	~	~	~	~	~

[Add User](#) [Modify User](#) [Delete User](#)

## IP Access Control

**IP Access Control**

IP Access Control Disabled. All IP will Accepted to this Device.

Add IP Accept Entry  To  [ADD](#)

Current IP Accept Entry List

[Enable IP Entry List](#)

## BMC Share NIC Switch

Enable BMC Share NIC  Enable

**NOTE: BMC should be reboot to enable switched share NIC!**

**Share NIC Switch**

Share NIC Switch  [Save](#) [Reset](#)

**Network Interface Switch**

Management Network Mode Switch  Auto Failover  Manual Switch

Channel Number  [Save](#) [Reset](#)

## 4.7 Logs

Select “Logs” on navigation tree, to open related log page, which contains four pages of “System Event Logs”, “BMC System Design Logs”, “Black Box Logs”, “Event Logs Configuration”, “BMC System Audit Logs Configuration”, as shown in Figure 2-26, Figure 2-27, Figure 2-28 and Figure 2-29.

- System event logs: Displays various event logs generated by server.
- BMC system audit logs: Displays system logs and audit logs of BMC.
- Black box logs: Used to import fault logs.
- Event logs configuration: Sets BMC logs storage strategies:
  - ★ Linear strategy: To clean all logs after log storage is full and record again.
  - ★ Circulation strategy: To record circularly after log record is full.
- BMC system audit logs configuration: Sets information about BMC system audit logs storage methods and lengths etc.

**System Event Log**

All Events  All Sensors

BMC Timezone  Client Timezone UTC Offset: (GMT+08:00)

Event ID	Time Stamp	Severity	Sensor Name	Sensor Type	Description
73	Pre-init Timestamp	<span style="color: blue;">●</span>	Intrusion	Physical Security (Chassis Intrusion)	General Chassis Intrusion - Asserted
72	Pre-init Timestamp	<span style="color: blue;">●</span>	Power Status	System ACPI Power State	Legacy OFF State - Asserted
71	01/06/2015 17:12:38	<span style="color: blue;">●</span>	Power Status	System ACPI Power State	Legacy OFF State - Asserted
70	01/05/2015 06:38:14	<span style="color: blue;">●</span>	Other	OS Boot	Boot Completed - Boot Device Not Specified - Asserted
69	Pre-init Timestamp	<span style="color: blue;">●</span>	Other	System Boot / Restart Initiated	System Restart - Asserted
68	Pre-init Timestamp	<span style="color: blue;">●</span>	Intrusion	Physical Security (Chassis Intrusion)	General Chassis Intrusion - Asserted
67	Pre-init Timestamp	<span style="color: blue;">●</span>	HDD_Status	Drive Slot (Bay)	Drive Presence - Asserted
66	Pre-init Timestamp	<span style="color: blue;">●</span>	PSU_Supply	Power Supply	Presence Detected - Asserted
65	Pre-init Timestamp	<span style="color: blue;">●</span>	HDD_Status	Drive Slot (Bay)	Drive Presence - Asserted
64	Pre-init Timestamp	<span style="color: blue;">●</span>	HDD_Status	Drive Slot (Bay)	Drive Presence - Asserted

Note:  
● Information ▲ Warning ● Critical

---

**BMC System Audit Log**

BMC System Logs **BMC Audit Log**

Alert  Event entries: 1

Event ID	Time Stamp	HostName	Description
1	Jan 6 20 04:44	6C82BF0C012A	kernel: Helper Module Driver Version 1.2

---

**Black Box Log**

Log Selection

---

**Event Log Setting**

Event Log Setting

Current Event Log Policy

System Event Log Policy Options

Circular Policy  
 Linear Policy  
 Circular Policy

■ System and Audit Log Settings

System and Audit Log Settings	
System Log	<input checked="" type="checkbox"/> Enable
Log Type	<input checked="" type="radio"/> Local Log <input type="radio"/> Remote Log
File Size (in bytes)	<input type="text" value="50000"/>
Rotate Count	<input type="text" value="0"/>
Server Address	<input type="text"/>
Audit Log	<input checked="" type="checkbox"/> Enable

## 4.8 Fault Diagnosis

Select “Fault Diagnosis” on navigation tree, to open fault diagnosis page, which contains three pages of “Task Restart”, “Last Crash Screen” and “System Power On Self test codes”. As shown in the following figure.

- Task restart: Contains restart two functions of restarting BMC and restarting KVM service;
- Last crash screen: Used to capture information on the last screen at system crash;



**Note:** Blue screen only adapts to Windows 2008R2 and Windows 2012 OS;

- System power on self test codes: Displays power-on codes during system startup.

■ BMC Recovery

BMC Recovery	
BMC Recovery Options	<input checked="" type="radio"/> BMC Warm Reset <input type="radio"/> KVM Service Restart

### ■ Last Crash Screen

This page will display the crash screen captured during failure happened in the host system.

Note: This last crash screen feature requires the managed system with the auto recovery feature configured.

Not Available

Host POST Code

Host POST Code	
Current Power Status	
Current POST Code	N/A
POST Code Records	N/A

## 4.9 System Maintenance

Select “System Maintenance” on navigation tree, to open system maintenance page, which contains three pages of “BMC Firmware Update”, “BIOS Firmware Update” and “Restore Factory Configuration”. As shown in Figure 2-33, Figure 2-34 and Figure 2-35.

- BMC firmware update: Carries out update on BMC FW via BMC Web interface;
- BMC firmware update: Carries out update on BMC via BMC Web interface;
- Restore factory configuration: Restores BMC’s configuration to factory state.

BMC Firmware Update

Please note:

1. After entering update mode widgets, other web pages and services will not work. All open widgets will be closed automatically. If upgrade process is cancelled in the middle of the wizard, the device will reset.
2. Click 'Preserve all configuration' will preserve all the configuration settings during the firmware update.
3. This section lists the configuration items, items that configured as 'Preserve' will be preserved during restore factory default configuration. Click 'Preserve Configuration' to modify the preserve configuration items.
4. Click 'Enter Firmware Update Mode' to update firmware.

Preserve all configuration

NO.	Preserve Settings	Update Policy
1	SDR	Overwrite
2	FRU	Overwrite
3	SEL	Overwrite
4	IPMI	Overwrite
5	Network	Overwrite
6	NTP	Overwrite
7	SSH	Overwrite
8	KVM	Overwrite
9	Authentication	Overwrite

Enter Preserve Configuration    Enter Firmware Update Mode

BIOS Firmware Update

Please note:

- (1) **Power Off** the system if you want to do BIOS Update.
- (2) BIOS NVRAM will be cleared and BIOS will become default after BIOS flashed.
- (3) After BIOS flashed, we recommend to **AC Power Off** and On to enable NEW BIOS.

1. Please click the button to enter firmware update mode.

Current Power Status	
BIOS Bin File Type	BIOS+ME

Enter Firmware Update Mode

Restore Factory Defaults

1. Please note that after entering into restore factory defaults, widgets, other web pages and services will not work. All open widgets will be closed automatically. The device will reset and reboot within few minutes.
2. This section lists the configuration items, items that configured as 'Preserve' will be preserved during restore factory default configuration. Click 'Preserve Configuration' to modify the preserve configuration items.
3. Click 'Restore Factory Defaults' after configuring preserve items.

NO.	Preserve Settings	Update Policy
1	SDR	Overwrite
2	FRU	Overwrite
3	SEL	Overwrite
4	IPMI	Overwrite
5	Network	Overwrite
6	NTP	Overwrite
7	SSH	Overwrite
8	KVM	Overwrite
9	Authentication	Overwrite

Enter Preserve Configuration    Restore Factory Defaults

## 4.10 Command Line Function Introduction

About this chapter

It introduces Web interface of management system as well as operation steps to login Web interface.

- Login command line  
Introduces methods of login command line.
- Command line function introduction  
Introduces command line functions.

### 4.10.1 Command line login:

Command line using ssh to login BMC, default user name: root, and default password: rootuser.

```
login as: root
root@10.53.11.240's password:
Executing [-/usr/local/bin/smashclp]
```

After login, you could enter the command line interface:

```
>> smashclp <<
////////////////////////////////////
smashclp cli tool version 0.9
Enter 'help' for a list of built-in commands
////////////////////////////////////
/smashclp> █
```

Enter help, you could view online help:

```
/smashclp> help
Built-in command:
-----
ipconfig:   get or set network parameters, please enter <ipconfig --help> for more information
sensor :   get or set sensor parameters, please enter <sensor --help> for more information
fru :      get or set fru parameters, please enter <fru --help> for more information
chassis :  get or set chassis parameters, please enter <chassis --help> for more information
user :     get or set user parameters, please enter <user --help> for more information
mc :       get or set mc parameters, please enter <mc --help> for more information
fan :      get or set fan parameters, please enter <fan --help> for more information
psu :      get or set psu parameters, please enter <psu --help> for more information
password:  change root password
exit :     exit the command line
/smashclp> █
```

### 4.10.2 Command Line Function Introduction

#### 4.10.2.1 Network Information Acquisition and Configuration:

You could acquire and configure BMC's network information via ipconfig instruction:



```
/smashclp> ipconfig --get
eth0
IP Address Source : dhcp
IP Address       : 10.53.11.240
Subnet Mask      : 255.255.255.0
Default Gateway IP : 10.53.11.254
MAC Address       : 6C:92:BF:07:1A:B6

eth1
IP Address Source : dhcp
IP Address       : 0.0.0.0
Subnet Mask      : 0.0.0.0
Default Gateway IP : 0.0.0.0
MAC Address       : 6C:92:BF:07:1A:B7
```

#### 4.10.2.2 Sensor Information Acquisition:

Via sensor instruction, you could acquire all sensor information lists:

```
/smashclp> sensor --list
sensor name | num | value | unit | status | lnr | lc | lnc | unc | uc | unr
CPU0_Temp   | 19h | 60.000 | degrees C | ok | na | na | na | 102.000 | 112.000 | na
CPU1_Temp   | 18h | na | degrees C | na | na | na | na | 102.000 | 112.000 | na
PCH_Temp    | 10h | 37.000 | degrees C | ok | na | na | na | 100.000 | 110.000 | na
DIMM0_Temp  | 1Eh | 30.000 | degrees C | ok | na | na | na | 95.000 | 105.000 | na
DIMM1_Temp  | 1Fh | na | degrees C | na | na | na | na | 95.000 | 105.000 | na
Inlet_Temp  | 02h | na | degrees C | na | na | na | na | 49.000 | 50.000 | na
Outlet_Temp | 00h | na | degrees C | na | na | na | na | na | na | na
SYS0_Temp   | 01h | na | degrees C | na | na | na | na | na | na | na
SYS1_Temp   | 03h | na | degrees C | na | na | na | na | na | na | na
HDD0_REAR_Temp | 04h | na | degrees C | na | na | na | na | 60.000 | 70.000 | na
HDD1_REAR_Temp | 08h | na | degrees C | na | na | na | na | 60.000 | 70.000 | na
RISER0_Temp | 05h | na | degrees C | na | na | na | na | na | na | na
RISER1_Temp | 06h | na | degrees C | na | na | na | na | na | na | na
GPU0_Temp   | 07h | na | degrees C | na | na | na | na | 82.000 | 92.000 | na
CPU1_Temp   | 08h | na | degrees C | na | na | na | na | 82.000 | 92.000 | na
MIC0_Temp   | 09h | na | degrees C | na | na | na | na | 104.000 | 114.000 | na
MIC1_Temp   | 0Ah | na | degrees C | na | na | na | na | 104.000 | 114.000 | na
SYS_VCCIO   | 40h | 1.070 | Volts | ok | 0.690 | 0.770 | 0.850 | 1.170 | 1.250 | 1.330
SYS_1V5    | 45h | 12.502 | Volts | ok | 9.024 | 9.776 | 10.528 | 13.536 | 14.288 | 15.040
SYS_3_3V   | 44h | 3.377 | Volts | ok | 2.660 | 2.800 | 2.940 | 3.657 | 3.797 | 3.938
SYS_5V     | 47h | 5.220 | Volts | ok | 3.888 | 4.176 | 4.464 | 5.544 | 5.832 | 6.120
PCH_P1V05  | 41h | 1.070 | Volts | ok | 0.770 | 0.850 | 0.930 | 1.170 | 1.250 | 1.330
PCH_P1V5   | 42h | 1.550 | Volts | ok | 1.180 | 1.260 | 1.340 | 1.670 | 1.750 | 1.830
CPU0_VCORE | 45h | 1.010 | Volts | ok | 1.040 | 1.120 | 1.200 | 2.300 | 2.380 | 2.460
CPU1_VCORE | 46h | na | Volts | na | 1.040 | 1.120 | 1.200 | 2.300 | 2.380 | 2.460
CPU0_DDR_VDDQAB | 48h | 1.220 | Volts | ok | 0.910 | 0.990 | 1.070 | 1.330 | 1.410 | 1.490
CPU0_DDR_VDDQCD | 49h | 1.200 | Volts | ok | 0.910 | 0.990 | 1.070 | 1.330 | 1.410 | 1.490
CPU1_DDR_VDDQEF | 48h | na | Volts | na | 0.910 | 0.990 | 1.070 | 1.330 | 1.410 | 1.490
CPU1_DDR_VDDQGH | 48h | na | Volts | na | 0.910 | 0.990 | 1.070 | 1.330 | 1.410 | 1.490
FAN_0      | 30h | 0.000 | RPM | cr | na | 0.000 | na | na | na | na
FAN_1      | 31h | na | RPM | na | na | 0.000 | na | na | na | na
FAN_2      | 32h | 0.000 | RPM | cr | na | 0.000 | na | na | na | na
FAN_3      | 32h | na | RPM | na | na | 0.000 | na | na | na | na
FAN_4      | 34h | 0.000 | RPM | cr | na | 0.000 | na | na | na | na
FAN_5      | 35h | na | RPM | na | na | 0.000 | na | na | na | na
FAN_6      | 36h | 0.000 | RPM | cr | na | 0.000 | na | na | na | na
FAN_7      | 37h | na | RPM | na | na | 0.000 | na | na | na | na
CPU0_Status | 6Ah | 0x0 | discrete | 0x8000 | na | na | na | na | na | na
CPU1_Status | 6Bh | 0x0 | discrete | 0x8000 | na | na | na | na | na | na
MEM_CH0A_Status | 70h | 0x0 | discrete | 0x8040 | na | na | na | na | na | na
```

#### 4.10.2.3 FRU Information Acquisition and Configuration:

Via FRU instruction, you could acquire FRU configuration information:

```
/smashclp> fru --get all
Chassis Type : Rack Mount Chassis
Chassis Part Number : 0
Chassis Serial : 0
Chassis Extra : NULL
Board Mfg Date : Mon Sep 8 13:17:00 2014
Board Mfg : Inspur
Board Product : Zhenzhu
Board Serial : 0
Board Part Number : 0
Product Manufacturer : Inspur
Product Name : NF5270M4
Product Part Number : 0
Product Version : 01
Product Serial : 0
Product Asset Tag : NULL
/smatchclp>
```

#### 4.10.2.4 Chassis Status Acquisition and Control:

Via chassis instruction, you could acquire and control system power status.

```
/smashclp> chassis --get --help
chassis commands:
chassis <option1> [<option2> <parameter>]
option1:
--help      show help information
?           show help information
--get       get chassis information
for example : chassis --get <option2> <parameter>
--set       set chassis information
for example : chassis --set <option2> <parameter>
option2:
power       set or get host status
identify    set or get UID status
parameter:
status      get host or UID status
on          set host status power on
off         set host or UID status power off
force       set UID status all the light
Set UID light on server seconds, Please put seconds in the followed identify
for example : chassis --set identify 15. Light on 15 Seconds
The Seconds must be greater than 0 and less than or equal to 240
```

Acquiring system power status:

```
/smashclp> chassis --get power status
The host status is on
```

#### 4.10.2.5 User Acquisition, Adding and Deleting:

Via user instruction, you could acquire the user list, to add or delete users.

```
/smashclp> user --help
user commands:
user <option> [<user id> [<user name>/<user priv>]]
option:
--help      show help information
?           show help information
--list      show all the user of the information
--add       Add new user information
for example : user --add <user id> <user name>
--password  Modify user password
for example : user --password <user id>
--privilege Modify user permissions
for example : user --privilege <user id> <user priv>
--delete    Delete user
for example : user --delete <user id>
<user name>, The user name cannot be longer than 16 bytes.
<user id>, The user id more than 0, less than 16.
<user priv>, The user priv is 2(USER), 3(OPERATOR), 4(ADMINISTRATOR) or 15(NO ACCESS).
The password does not exceed 16 bytes.
```

Acquiring user list:

```
/smashclp> user --list
ID Name Channel Priv Limit
1 admin ADMINISTRATOR
2 NO ACCESS
3 NO ACCESS
4 NO ACCESS
5 NO ACCESS
6 NO ACCESS
7 NO ACCESS
8 NO ACCESS
9 NO ACCESS
10 NO ACCESS
11 NO ACCESS
12 NO ACCESS
13 NO ACCESS
14 NO ACCESS
15 NO ACCESS
16 NO ACCESS
```

#### 4.10.2.6 BMC Version Acquisition and BMC Restart

Via mc instruction, you could acquire BMC version information, and restart BMC.

```

/smashclp> mc --help
mc commands:
mc <option1> [<option2>] <parameter>
option1:
--help      show help information
?           show help information
--get       get mc information
for example : mc --get <parameter>
--set       set mc information
for example : mc --set <option2> <parameter>
option2:
bmc         set bmc action, this only support --set
kvm         set kvm action, this only support --set
parameter:
version     get bmc version, this only support --get command
reset      set bmc or kvm reset action, this only support --set command
  
```

Acquiring BMC version information:

```

/smashclp> mc --get version
Device ID           : 32
Device Revision     : 1
Firmware Revision   : 4.5.0
IPMI Version        : 2.0
  
```

#### 4.10.2.7 Fan Work Mode Configuration and Fan Rotation Rate Acquisition:

Via fan instruction, you could either set fan work mode, or acquire fan rotation rate.

```

/smashclp> fan --help
fan commands:
fan <option1> [<option2> <parameter1> [<parameter2>]]
option1:
--help      show help information
?           show help information
--get       get fan information
for example : fan --get <option2>
--set       set fan information
for example : fan --set <option2> <parameter1> [<parameter2>]
option2:
fanmode     set or get fanmode
for example : fan --set fanmode 0|1
0 : auto mode
1 : manual mode
fanlevel    set or get fan level
for example : fan --set fanlevel <parameter1> <parameter2>
parameter1: the fan id
parameter2: the fan of the present
  
```

Fan rotation rate acquisition:

```

/smashclp> fan --get fanlevel
ID  Status  SpeedPercent  SpeedRPM
0   NA      0              0 PRM
1   NA      0              0 PRM
2   NA      0              0 PRM
3   NA      0              0 PRM
4   NA      0              0 PRM
5   NA      0              0 PRM
6   NA      0              0 PRM
7   NA      0              0 PRM
  
```

#### 4.10.2.8 Power Module Information Acquisition and Configuration:

Via `Psu` instruction, you could either acquire power module information, or set power module as main output.

```
/smashclp> psu --help
psu commands:
psu <option1> <option2> [<parameter1> <parameter2>]
option1:
--help      show help information
?           show help information
--get       get psu information
for example : psu --get <option2>
--set       set psu information
for example : psu --set <option2> [<parameter1> <parameter2>]
option2:
psuinfo    show all psu information, this only support --get
psumode     set psu information, this only support --set
parameter1: the ID of the PSU module, not more than 1
parameter2: the action of the PSU module. 0 representation activate, 1 representation standby.
```

Power module information acquisition:

```
/smashclp> psu --get psuinfo
PSU Asset Info:
ID | Mfr ID      | Mfr Model      | Serial Number | FW Ver
0  | N/A         | N/A            | N/A          | N/A
1  | N/A         | N/A            | N/A          | 1.000
PSU Monitor Info:
ID | Status | Alert | Temp(C) | Pin (W) | Pout (W) | Vin (V) | Vout (V) | Iin (A) | Iout (A)
0  | N/A    | N/A   | N/A     | N/A     | N/A      | N/A     | N/A      | N/A     | N/A
1  | Activate | OK    | 24     | 56     | 40       | 231    | 12.33   | 0.26    | 3.28
```

#### 4.10.2.9 Change Root Password:

Via `password` instruction, you could change root user's password:

```
/smashclp> password
New password: █
```

## 4.11 Time Zone Table

Time Zone	Countries and Regions
GMT-12:00	West Date Line
GMT-11:00	Applia, Niue, Pago Pago, Midway
GMT-10:00	Fakaofu, Rarotonga, the island of Tahiti, Johnston, Hawaii
GMT-09:30	Marquesas
GMT-09:00	Alaska, Gambier Islands
GMT-08:00	Pacific Time (USA and Canada), Pitcairn, Whitehorse, Tijuana, Vancouver
GMT-07:00	Mountain Time (USA and Canada), Edmonton, Hermosillo, the Tao gave birth to Crick, Chihuahua, Yellowknife, Arizona, Mazatlan
GMT-06:00	Central Time (USA and Canada), Belize, Costa Rica, Easter Island, Galapagos Islands, Salvatore, Guatemala, Managua, Mexico City, Regina, Winnipeg

GMT-05:00	Eastern Time (USA and Canada), Panama, Bogota, Toronto, Grand Turk Island, Montreal, Iqaluit, Guayaquil, Havana, the Cayman Islands, Leo Brown Cu, Lima, Nassau, Port au Prince, Jamaica
GMT-04:00	Atlantic Time (Canada), Aruba, Anguilla, Antigua, Babado J, Bermuda, Puerto Rico, Bo Avesta, Campo Grande, Halifax City, Dominica, Grenada, Guadeloupe, Guyana, Caracas, Curacao, Cuiaba, Labasse, Martinique, Manaus, Montserrat, Palmer, Santiago, Santo Domingo, St. Kitts, St Lucia, St. Thomas, Vincent, STANLEY, Thule, Tortora, Porto Velho, port of Spain, Asuncion
GMT-03:30	St. Louis
GMT-03:00	Aragua ina, Belem, Buenos Aires, Fortaleza, Geert Holob, cayenne, Recife, Lutheran, Maceio, Montevideo, Miquelon Island, Paramaribo, Salvatore, St. Paul
GMT-02:00	South Georgia, Noronha
GMT-01:00	Cape Verde, Si kolle SBI Sander, Azores
GMT+00:00	Abidjan, Accra, Bamako, Banjul, Laayoune, Bissau, Dakar, Dublin, Freetown, Greenland, the Canary Islands, Casablanca, Conakry, Reykjavik, Lisbon, London, Monrovia, Nouakchott, Saint Lome, how beautiful, St. Helena, Ouagadougou
GMT+01:00	Algiers, Amsterdam, Andorra, Oslo, Paris, Berlin, Bangui, Porto Novo, Budapest, Brazzaville, Brussels, Tirana, Douala, Ndjamen, Copenhagen, Warsaw, Kinshasa, Lagos, Liebe Weil, Luxemburg, Luanda, Rome, Madrid, Malta, Monaco, Niamey, Stockholm, Guinea, Zurich, Tunisia, Vaduz, Vienna, Windhoek, Ceuta, Gibraltar
GMT+02:00	Amman, Beirut, Bucharest, Blantyre, Bujumbura, Damascus, Tripoli, Harare, Habo Roney, Helsinki, Kiev, Kigali, Kihine U, Cairo, Gaza, Riga, Lubumbashi, Lusaka, Maputo, Minsk, Kaliningrad, Maseru, Mbabane, Nicosia, Sofia, Tallinn, Tel Aviv, Vilnius, Athens, Istanbul, Johannesburg
GMT+03:00	Antananarivo, Baghdad, Bahrain, Dar Es Salaam, Djibouti, Qatar, ha Khartoum, Kampala, Comoros, Kuwait, Mayotte, Riyadh, Mogadishu, Moscow, Nairobi, Addisababa, Aden, Showa
GMT+03:30	Newfoundland
GMT+04:00	Baku, Dubai, Tbilisi, Reunion Island, Mahe, Muscat, Mauritius, Samarra, Ye Liewan
GMT+04:30	Kabul
GMT+05:00	Aktau Aktobe, Ashkhabad, Karachi, Dushanbe, Kell islands, Maldives, Kelang, Yekaterinburg, Tashkent
GMT+05:30	Colombo, India



GMT+06:00	Ala Mutu, Bishkek, Chagos, Dhaka, Mo Sen, Omsk, Novosibirsk, Thimphu, Vostok
GMT+06:30	The Coco Islands, Yangon
GMT+07:00	Davies, Hanoi, Phnom Penh, Khovd, Bangkok, Lasinuoyaersike, Christmas Island, Vientiane, Jakarta
GMT+08:00	Macao, Kuala Lumpur, Manila, Ilkuts J, Casey, Macassar, Taipei, Brunei, Ulan Bator, Perth, Singapore, Beijing, Hongkong, China
GMT+09:00	Chaya Pla, Dili, Tokyo, Yakutsk, Palau, Pyongyang, Qiao Bashan, Seoul
GMT+09:30	Adelaide, Darwin
GMT+10:00	Di Mundi Weil, Brisbane, Hobart, Melbourne, Sydney, Guam, Port Moresby, Yuzhno-Sakhalinsk, Saipan, Truc
GMT+11:00	Efate, Ponape Island, Guadalcanal, Kosrae, Magadan, Noumea
GMT+11:30	Nuo Fuke
GMT+12:00	Oakland, Funafuti, Kwajalein, Majuro, Pietro Pavlov's Kamchatka, Tarawa Island, Wallis, Wake Island, Nauru, Fiji
GMT+13:00	Nukualofa

## 5 Hardware Maintenance

### 5.1 Tool Preparation

- Tools to be prepared before construction, as shown in the following table.

Tool List

Illustration	Name	Description
	Phillips Screwdriver	Used to fix bolts.
	Anti-static Wrist Strap	Used to contact or operate devices and apparatuses, to prevent static electricity.
	Anti-static Gloves	Used to plug in single board, hand-held single board or other precision instruments etc., to prevent static electricity.

### 5.2 Parts Replacement

Special tips: Except hot plugging parts (i.e. hot plugging hard disk etc.), all part replacements could only be carried out with power disconnected.

#### 5.2.1 Processor Replacement

During installing and replacing CPU, please pay attention to the following issues:

- During installing two CPUs, type of these two CPUs shall be the same.
- When only one CPU is to be installed, please operate according to the following requirements:
  - 1) This CPU has to be installed on CPU0's socket, and see [Mainboard Diagram] for CPU position.
  - 2) It is not allowed to dismantle the protective cover on sockets without CPU1 installed.

Step 1: Open two pull rods on CPU slot, and open CPU fixing plate.

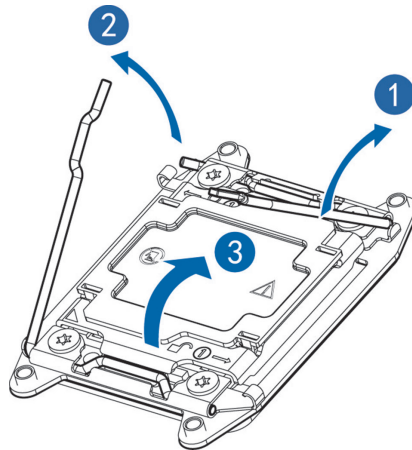

Step 2: Install CPU into CPU slot, and then remove protective cover on CPU slot.

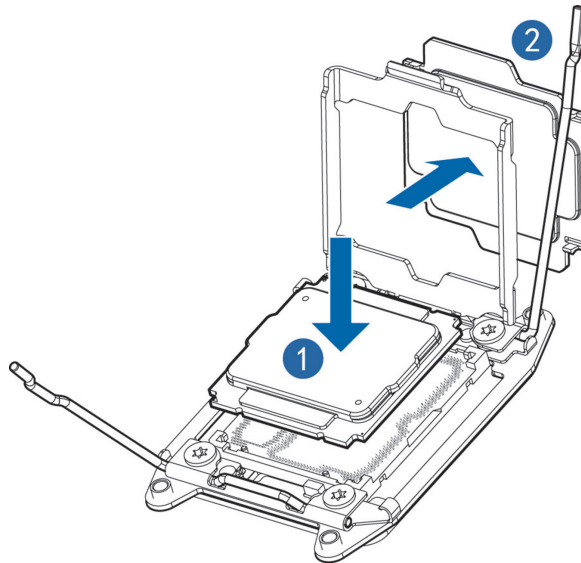

Step 3: Clamp CPU with CPU fixing plate, and then fix two pull rods firmly.

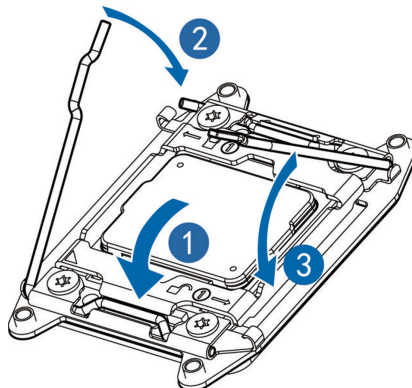



Step 4: Fix CPU heat radiator above CPU, and fasten bolts on heat radiator.

**Note:**

- It is required to coat thermal grease evenly onto contact position between CPU heat radiator and CPU.
- Fins of CPU heat radiator must be installed in the direction corresponding to system inlet/outlet.
- During fixing CPU heat radiator, it is required to fasten bolts according to diagonal sequence accordingly.

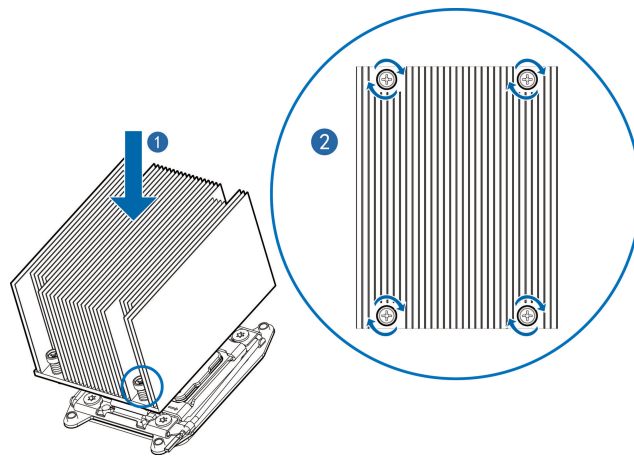

### 5.2.2 Memory Replacement

- Memory slot layout is as shown in the following figure:

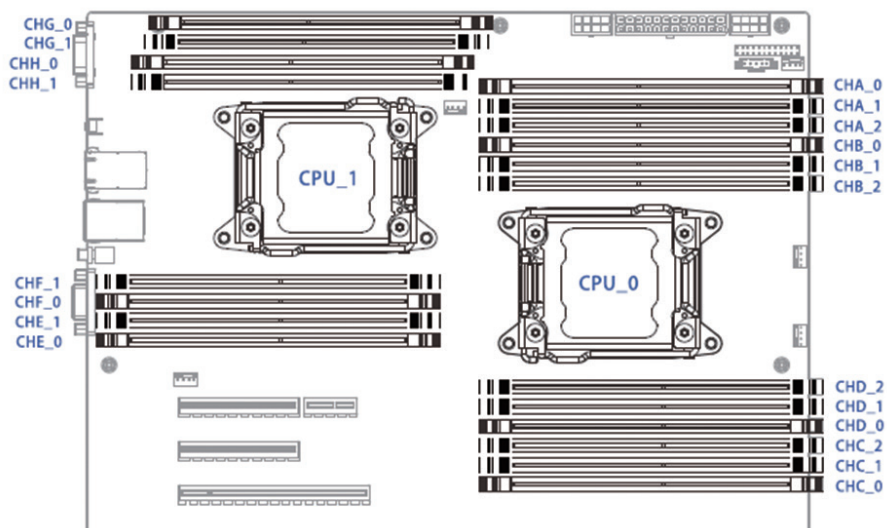

- Memory installation principle:

Only memory of the same type could be used in the same machine. Detailed memory installation and combination principles are as follows:

a、 The white slot shall take the priority, while CPU1 memory shall be symmetrically installed with CPU0.

b、 For single CPU, memory shall follow the screen printing sequence: CHA-0, CHB-0, CHC-0, CHD-0, CHA-1...

c、 For dual CPUs, CPU0 position memory shall follow the screen printing sequence: CHA-0, CHB-0, CHC-0, CHD-0, CHA-1...;CPU1 position memory follow the screen printing sequence: CHE-0, CHF-0, CHG-0, CHH-0, CHE\_1...

Step 1: Open fixing catches on both ends of memory slot.

Step 2: Align the notch at memory bottom with memory slot positioning point, and press both ends of the memory with your thumbs, to insert the memory into the slot completely, and then fasten fixing catches on both ends of the memory slot.

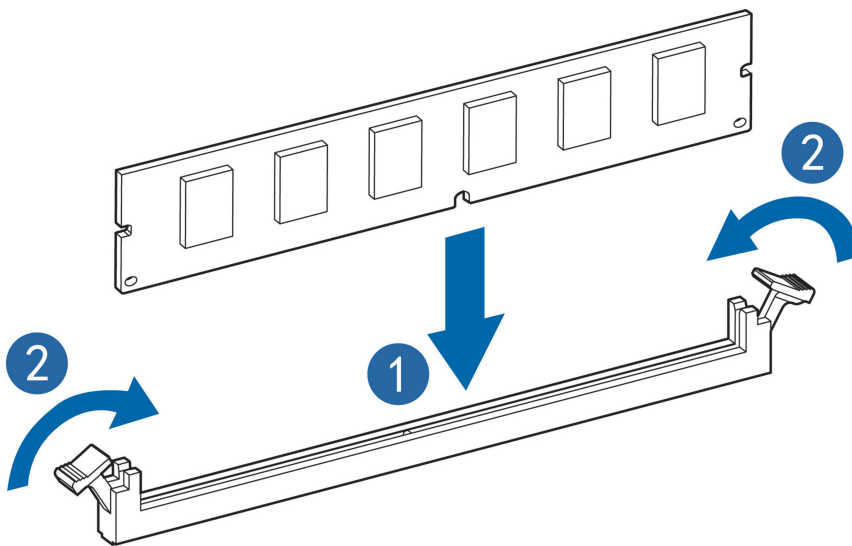

### 5.2.3 Hard Disk Replacement

Step 1: Press hard disk panel button.

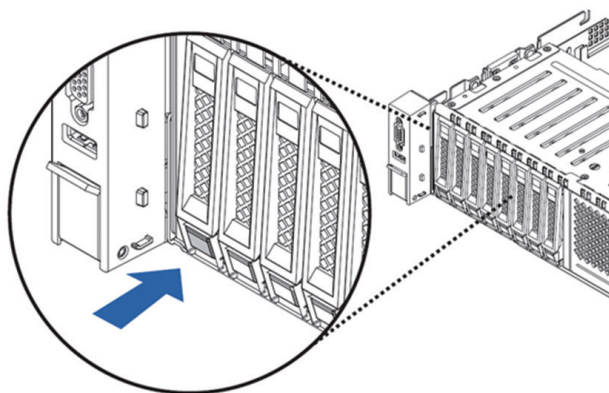

Step 2: Pop up buckles on hard disk bracket automatically, flatten and dismantle hard disk bracket.

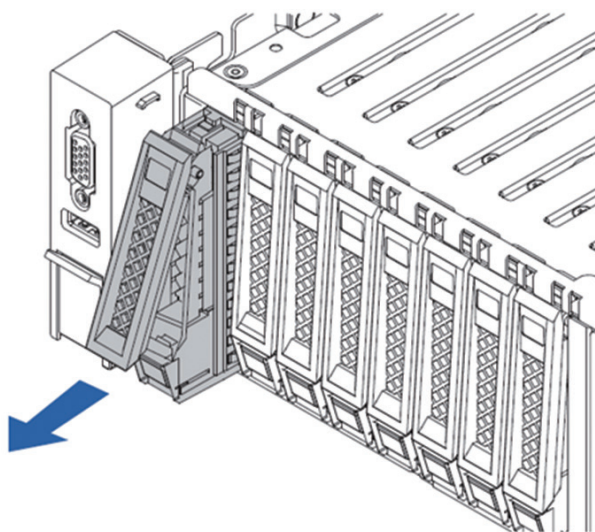

Step 3: Use four hard disk bolts to fix the hard disk onto the bracket.

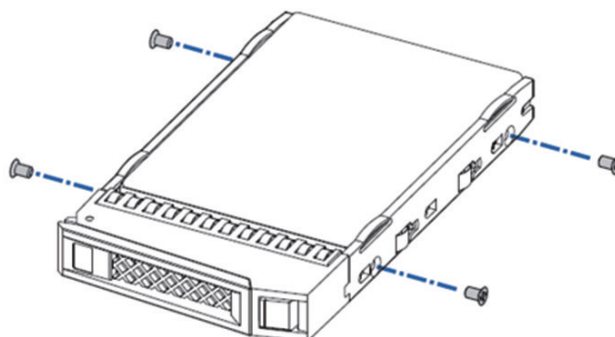

Step 4: Install the hard disk into the server, and fasten hard disk buckles firmly.

### 5.2.4 Power Replacement

Step 1: Pull power catch in the direction of the arrow.

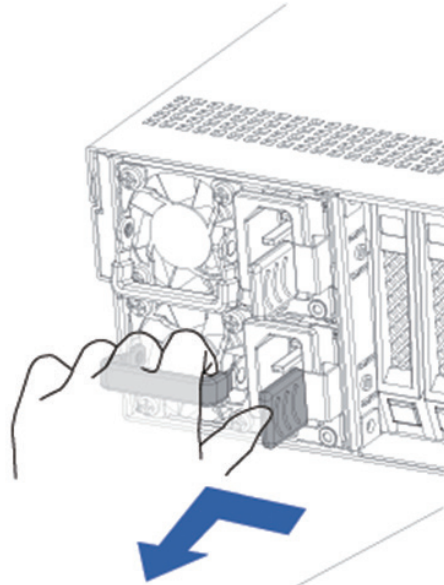

Step 2: Remove the power horizontally with even force.

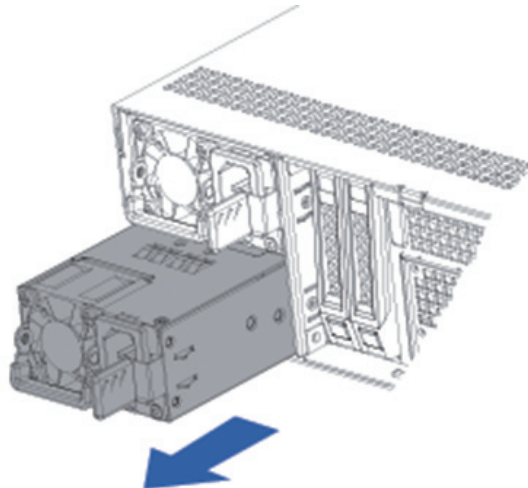

Figure 3: Install power module.

Push the new power module into the sliding channel, until a “click” sound is heard, power spring leaf is caught into the buckle automatically, and power module could not move any more.

### 5.2.5 Chassis Cover Replacement

Step 1: Turn the chassis cover lock to the open position.

Step 2: Press the lock button.

Step 3: Turn the lock to its maximum openness.

Step 4: Vertically remove the chassis cover upwards.

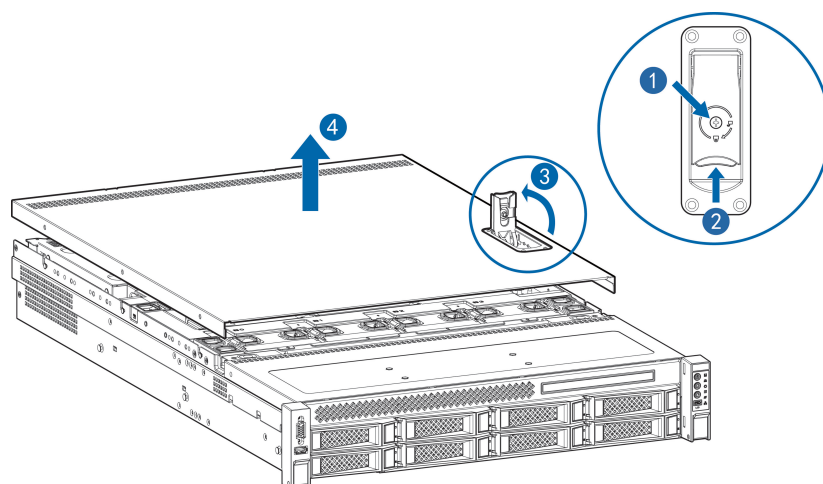

### 5.2.6 System Fan Replacement

Hold the both ends of the fan, and vertically remove the single fan upwards.

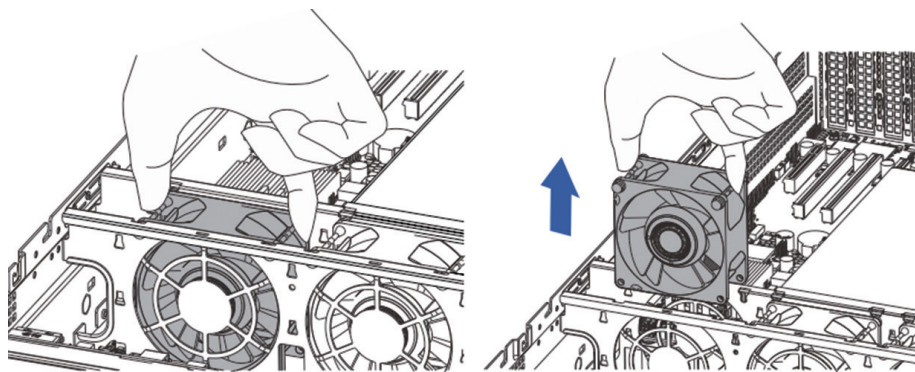

### 5.2.7 PCIE Expansion Card Replacement

Step 1: Insert a screw driver into the cross slot on top of the blocking piece, then pry and take down the blocking piece as shown in the following figure.

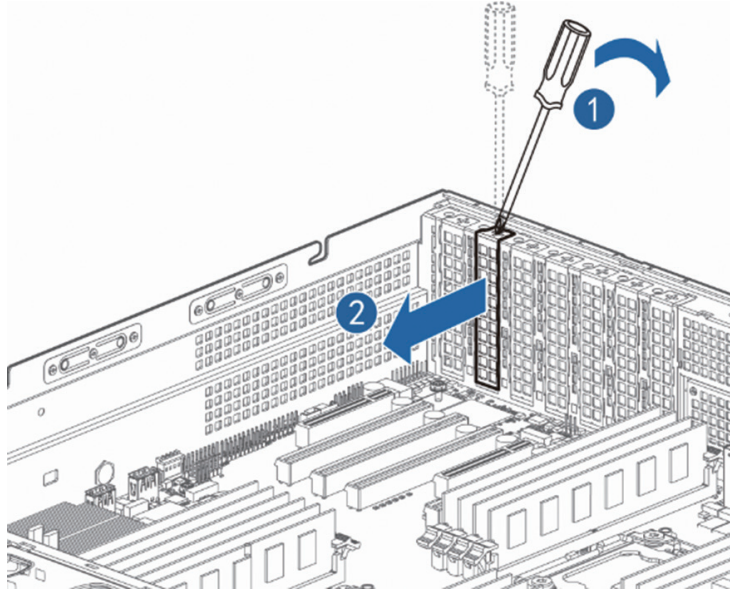

Step 2: Install a matching blocking piece onto expansion card, and insert the expansion card into the slot corresponding to PCIE card.

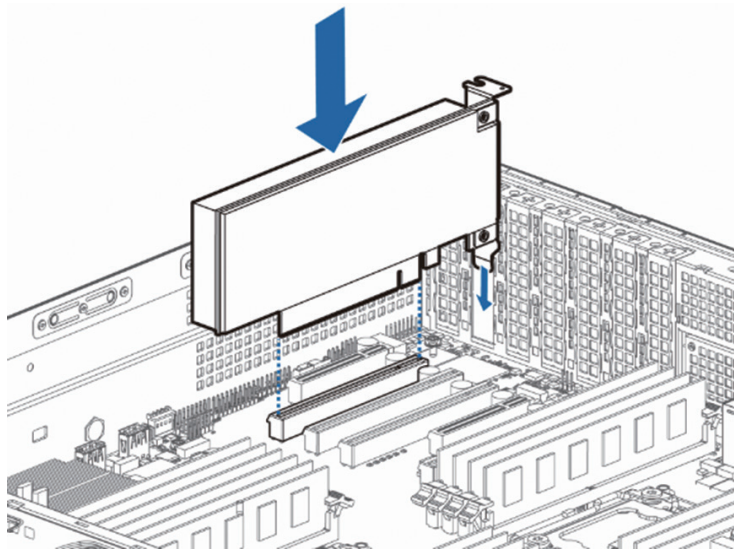

Step 3: Install the riser card bracket back to the server.

### 5.2.8 Wind Scooper Replacement

Step 1: Open upper cover of the chassis.

Step 2: Pull buckles inwards on both ends of the wind scooper, and then vertically remove the wind scooper upwards.

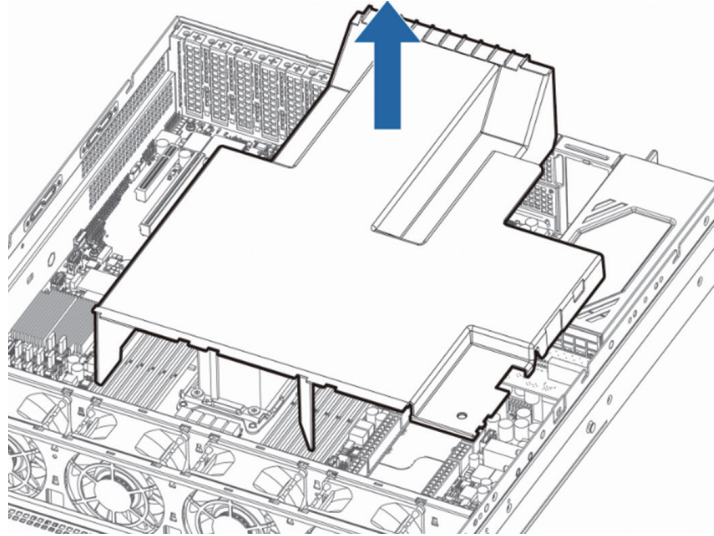

### 5.2.9 USB Flash Disk Replacement

Step 1: Decide USB Flash disk position.

Step 2: Remove the USB Flash disk along reversal direction of USB interface.

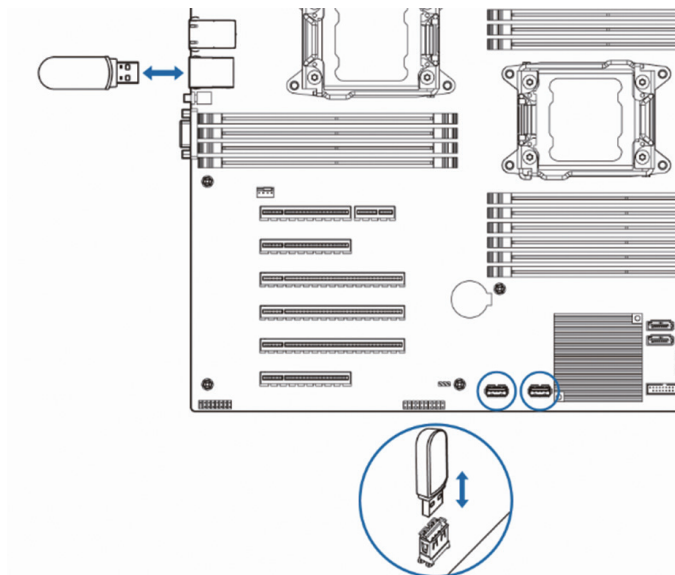

### 5.2.10 Mainboard Replacement

Step 1: Dismantle all parts and cables connecting to mainboard.

Step 2: Use a screwdriver to remove the screws on the mainboard, and vertically remove the mainboard upwards.

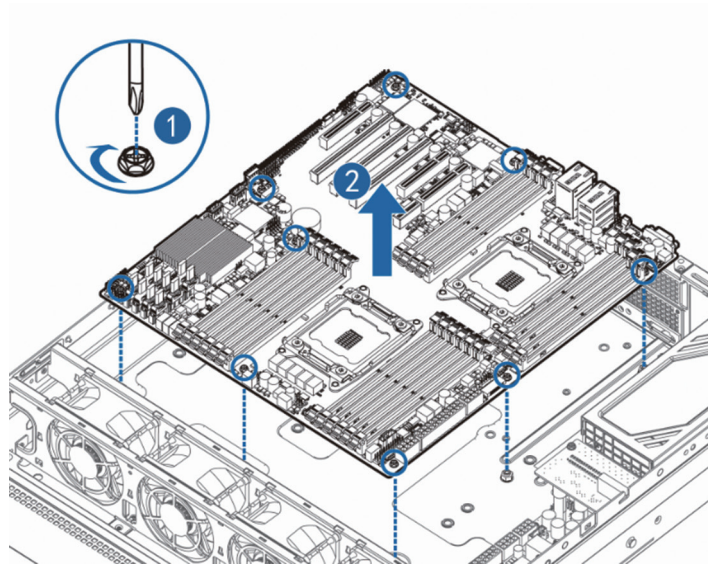

### 5.2.11 Front Set Hard Disk Backplane Replacement

Steps: Depart hard disk backplane from fixed legs of the chassis; vertically remove the chassis buckles upwards, and then remove the hard disk backplane outwards.

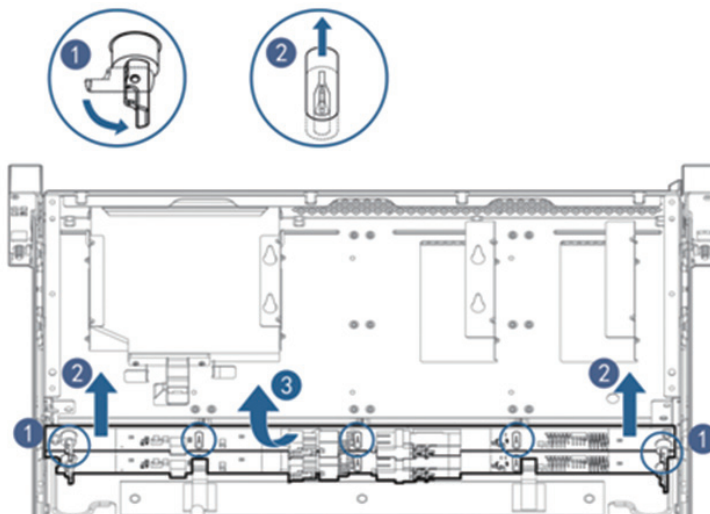

### 5.2.12 Power Supply Backplane Replacement

Step 1: Dismantle all parts and cables connecting to power supply backplane.

Step 2: Use a screwdriver to remove the screws on the power supply backplane, and vertically remove the power supply backplane upwards.



### 5.2.13 Rear Set Hard Disk Backplane Replacement

Steps: Depart hard disk backplane from fixed legs of the chassis, vertically remove the chassis buckles upwards, and then remove the hard disk backplane outwards.

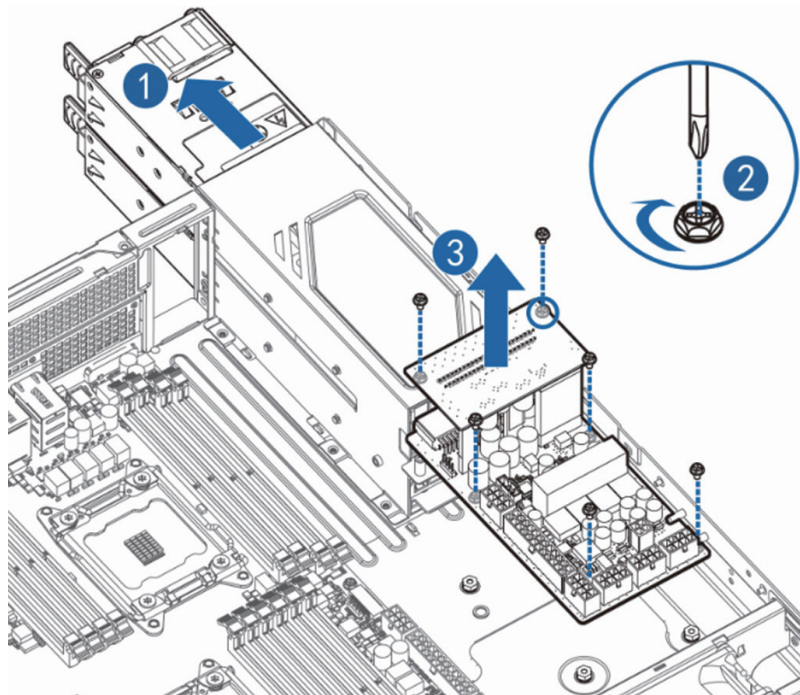

## 6. Frequent Faults, Diagnosis and Troubleshooting

This chapter introduces

Frequent server faults as well as corresponding diagnosis and troubleshooting suggestions.

### 6.1 Frequent Faults

1) No power after startup

After the machine is connected with power cable, no power is provided for the machine while pressing the On/Off button, and indicator does not light up after power on.

2) Power module indicator off or red indicator on

The machine is under normal operation, but a certain power module indicator is off or red indicator is on to alarm.

3) No display after power on

No information output appeared on the display after power on via pressing On/Off button.

4) Front panel indicator is off

All front panel indicators are off after power on.

5) Front panel status indicator alarms

The machine is under normal operation, but status indicator alarms.

6) Blank screen of the display

Blank screen fault occurs during display usage.

7) Abnormal display

Trembling, rolling or twisting screen images on the display during machine usage.

8) Memory capacity displays abnormality

It is shown by the operation system that memory capacity does not correspond with physical memory capacity.

9) Keyboard and mouse are not available

Neither keyboard nor mouse could be operated normally.

10) USB interface problem

Introduces solutions to failing to use USB interface.

## 6.2 Diagnosis and Exclusion Instructions

### 1) Diagnosis and exclusion on power-on failure at startup

Description: After pressing the power button, server front control panel indicator (power-on status indicator, hard disk status indicator) is off, meanwhile, no KVM (display) output is displayed, and server chassis fan does not rotate.

#### Operation steps:

- a、 Verify whether machine power supply is normal or not: If power module indicator is on, it indicates normal power supply; if power module indicator is off, please check if power supply is normal;
- b、 If power supply is normal, plug in and off the power module again to test, and then start for verification;
- c、 If there's a machine and a power module of the same type, you could change the power module to test whether there's a power module fault;
- d、 If no solution could be achieved via the above operation, please contact the distributor customer service.

### 2) Power module indicator off or red indicator on

Description: The machine is under normal operation, but a certain power module indicator is off or the red light is on.

#### Operation steps:

- a、 Firstly check whether all power cables are normal, and plug in power cables again;
- b、 If fault still exists, plug in and off power module again;
- c、 If shutdown is allowed, you could exchange these 2 power modules, to judge whether it is a power module fault.
- d、 If no solution could be achieved via the above operation, please contact the distributor customer service.

### 3) No display if power on

Description: After pressing the power button, server front control panel indicator is on, but there's no output on the display.

#### Operation steps:

- a、 Firstly check whether VGA port on display and server is connected normally;

- b、 Test on another display
- d、 If no solution could be achieved via the above operation, please contact the distributor customer service.

#### 4) Front panel status indicator alarms

Description: The server is under normal operation, but system status indicator on front control panel flashes or the red indicator is on to alarm.

##### Operation steps:

Please check whether all power module indicators are green constant, if so, you could login BMC web interface to collect logs, and contact the distributor customer service.

#### 5) Memory capacity incomplete

Description: Memory capacity viewed via the operation system does not correspond with physical memory capacity.

##### Operation steps:

- a、 Ensure all memories have been correctly installed in place, and memories of correct type have also been configured.
- b、 Enter BIOS setup to view memory capacity, if it could be completely identified in BIOS setup, this may lie in the limitation on memory capacity set by the operation system. Otherwise, please contact the distributor customer service.

#### 6) Keyboard and mouse are not available

Description: Neither keyboard nor mouse could be operated normally.

##### Operation steps:

- a、 Make sure whether cable connection of keyboard or mouse is correct and firm.
- b、 Test other parts to verify whether it is a mouse or keyboard fault.
- c、 Retest the machine via power on/off.
- d、 Reboot and enter cmos or raid configuration interface to test keyboard or mouse performance, when tested in a non-system situation, if keyboard or mouse performance turns out to be normal, a system fault could be considered; if keyboard or mouse fault still exists, a mainboard interface fault could be considered, and you could contact the distributor technical support.

## 7) USB interface problem

Description: Unable to use devices with a USB interface.

### Operation steps:

- a、 Make sure operation system on server supports USB devices.
- b、 Make sure system has been installed with correct USB device driver.
- c、 Power off the server, and then power on again to test.
- d、 Make sure whether the USB device is normal when connecting to other hosts.
- e、 If the USB device is normal when connecting to other hosts, the server may be abnormal, please contact the distributor technical support; if the USB device turns out to be abnormal when connecting to other hosts, change the USB device.

## 7 Specifications

This chapter introduces various access authentications achieved by this product and standards it complies with.

- USA FCC statement.

Introduces FCC standards abided by the product.

- CE statement of EU.

Introduces CE standards abided by the product.

- China CCC

Introduces CCC standards abided by the product.

- China Environmental Symbols

Introduces China environmental symbols standards abided by the product.

### 7.1 USA FCC Statement

Introduces FCC standards abided by the product.

It is regulated in Subpart B, Part 15 of 47 CFR by Federal Communications Commission of the United States that users of this product shall pay attention to the following issues:

Annotations: This device has been tested and complies with regulations related to Class A digital devices in Part 15 of FCC rules. Main purpose of these limitations is to provide reasonable protection while operating such devices in business districts, to avoid harmful disturbance. This device may produce, use and emit RF energy, if installation or usage is carried out not according to instructions, harmful disturbance may be caused on radio communication. Operating this device in residential areas may cause harmful disturbance, in this case, the user will be responsible for all costs arisen from correcting disturbance.

If the user carries out change or correction not expressly indicated by our company, it may cause the device failing to comply with FCC Class A requirements, and exempted from its authorization to operate this device.

### 7.2 CE Statement of EU

This chapter introduces CE standards abided by this product.

This is a Class A product. In the dwelling environment, this product may cause radio disturbance, in this case, the user will be asked to adopt certain appropriate measures.

### 7.3 China CCC

This chapter introduces the CCC standards to be abided by the product.

This product is a class A product, in daily life, it may cause radio disturbance, in this case, it is required to adopt practicable precautions against its disturbance.

## 7.4 China Environmental Symbols

The products comply with China environmental symbols criteria.

Name of Hazardous Substances or Elements in the Product & Content Mark Table – Server

Part Name	Toxic and Harmful Substances or Elements					
	Pb	Hg	Cd	Cr(VI)	PBB	PBDE
Case	×	○	○	○	○	○
Mainboard	×	○	○	○	○	○
Memory	○	○	○	○	○	○
Hard Disk	○	○	○	○	○	○
Power Supply	×	○	○	○	○	○
Cable	○	○	○	○	○	○
Floppy drive	×	○	○	○	○	○
CD Drive	×	○	○	○	○	○
External Plug-in Net Card	×	○	○	○	○	○
External Plug-in Storage Card	○	○	○	○	○	○
Connection Plate Card	×	○	○	○	○	○
Data Cable	×	○	○	○	○	○
Keyboard	×	○	○	○	○	○
Mouse	×	○	○	○	○	○
Central Processor	×	○	○	○	○	○
Processor Radiator	×	○	○	○	○	○
Rail	○	○	○	○	○	○
Printing	○	○	○	○	○	○
CD	○	○	○	○	○	○
Package	○	○	○	○	○	○
Packing Pads	○	○	○	○	○	○
Packing Plastic Bags	○	○	○	○	○	○
<p><b>Instructions:</b></p> <p>1. ○: Indicates content of hazardous substances in all homogenous materials of this part is below limit regulated in Requirements for Concentration Limits for Certain Hazardous Substances in Electronic Information Products.</p> <p>2. ×: Indicates content of hazardous substances in at least one homogenous material of this part is below limit regulated in Requirements for Concentration Limits for Certain Hazardous Substances in Electronic Information Products. In the table, “×” indicates printed board welding technique limit fails to reach limit requirements.</p> <p>3. All the above parts are possible configuration parts in product, for actual product configuration please refer to configuration label.</p>						