

SUPERO[®]

SC513 Chassis Series

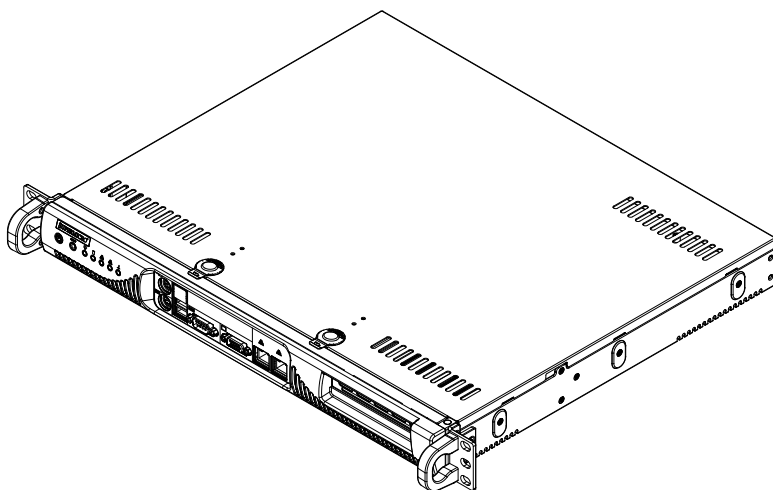

SC513L-420(B)

SC513L-410(B)

SC513F-350B

SC513F-260(B)

SC513L-260(B)

USER'S MANUAL

1.0a

The information in this User's Manual has been carefully reviewed and is believed to be accurate. The vendor assumes no responsibility for any inaccuracies that may be contained in this document, makes no commitment to update or to keep current the information in this manual, or to notify any person or organization of the updates. **Please Note: For the most up-to-date version of this manual, please see our web site at www.supermicro.com.**

Super Micro Computer, Inc. ("Supermicro") reserves the right to make changes to the product described in this manual at any time and without notice. This product, including software and documentation, is the property of Supermicro and/or its licensors, and is supplied only under a license. Any use or reproduction of this product is not allowed, except as expressly permitted by the terms of said license.

IN NO EVENT WILL SUPERMICRO BE LIABLE FOR DIRECT, INDIRECT, SPECIAL, INCIDENTAL, SPECULATIVE OR CONSEQUENTIAL DAMAGES ARISING FROM THE USE OR INABILITY TO USE THIS PRODUCT OR DOCUMENTATION, EVEN IF ADVISED OF THE POSSIBILITY OF SUCH DAMAGES. IN PARTICULAR, SUPERMICRO SHALL NOT HAVE LIABILITY FOR ANY HARDWARE, SOFTWARE, OR DATA STORED OR USED WITH THE PRODUCT, INCLUDING THE COSTS OF REPAIRING, REPLACING, INTEGRATING, INSTALLING OR RECOVERING SUCH HARDWARE, SOFTWARE, OR DATA.

Any disputes arising between manufacturer and customer shall be governed by the laws of Santa Clara County in the State of California, USA. The State of California, County of Santa Clara shall be the exclusive venue for the resolution of any such disputes. Super Micro's total liability for all claims will not exceed the price paid for the hardware product.

California Best Management Practices Regulations for Perchlorate Materials: This Perchlorate warning applies only to products containing CR (Manganese Dioxide) Lithium coin cells. "Perchlorate Material-special handling may apply. See www.dtsc.ca.gov/hazardouswaste/perchlorate"

WARNING: Handling of lead solder materials used in this product may expose you to lead, a chemical known to the State of California to cause birth defects and other reproductive harm.

Manual Revision 1.0a
Release Date: October 11, 2010

Unless you request and receive written permission from Super Micro Computer, Inc., you may not copy any part of this document.

Information in this document is subject to change without notice. Other products and companies referred to herein are trademarks or registered trademarks of their respective companies or mark holders.

Copyright © 2010 by Super Micro Computer, Inc.
All rights reserved.

Printed in the United States of America

Preface

About This Manual

This manual is written for professional system integrators and PC technicians. It provides information for the installation and use of the SC513 1U chassis. Installation and maintenance should be performed by experienced technicians only.

Supermicro's mini-sized SC513 1U chassis features easy-access front I/O ports and a depth of only fourteen inches, especially designed for space-limited applications.

This document lists compatible parts available when this document was published. Always refer to the our Web site for updates on supported parts and configurations.

Manual Organization

Chapter 1: Introduction

The first chapter provides a checklist of the main components included with this chassis and describes the main features. This chapter also includes contact information.

Chapter 2: System Safety

This chapter lists warnings, precautions, and system safety. You should thoroughly familiarize yourself with this chapter for a general overview of safety precautions that should be followed before installing and servicing this chassis.

Chapter 3: Chassis Components

Refer here for details on this chassis model including the fans, bays, airflow shields, and other components.

Chapter 4: System Interface

This section provides details on the system interface, which includes the functions and information provided by the control panel on the chassis as well as other LEDs located throughout the system.

Chapter 5: Chassis Setup and Maintenance

Follow the procedures given in this chapter when installing, removing, or reconfiguring your chassis.

Chapter 6: Rack Installation

Refer to this chapter for detailed information on chassis rack installation. You should follow the procedures given in this chapter when installing, removing or reconfiguring your chassis into a rack environment.

Appendix A: Cables, Screws, and Other Accessories

Appendix B: Power Supply Specifications

Table of Contents

About This Manual	iii
Manual Organization	iv
Chapter 1 Introduction	
1-1 Overview	1-1
1-2 Chassis Features	1-2
CPU	1-2
I/O Expansion slots	1-2
Dual Hard Drives	1-2
1-3 Contacting Supermicro	1-3
1-4 Returning Merchandise for Service	1-4
Chapter 2 System Safety	
2-1 Overview	2-1
2-2 Warnings and Precautions	2-1
2-3 Preparing for Setup	2-1
2-4 Electrical Safety Precautions	2-1
2-5 General Safety Precautions	2-3
2-6 System Safety	2-3
Chapter 3 Chassis Components	
3-1 Overview	3-1
3-2 Components	3-1
Chassis	3-1
Fans and Blower Units	3-1
Mounting Rails	3-1
Power Supply	3-1
Air Shroud	3-2
3-3 Where to get Replacement Components	3-2
Chapter 4 System Interface	
4-1 LED Panel Overview	4-1
4-2 Control Panel Buttons	4-2
4-3 Control Panel LEDs	4-2
4-4 I/O Panel Overview	4-4

Chapter 5 Chassis Setup and Maintenance

5-1	Overview	5-1
5-2	Installation Procedures.....	5-1
	General Maintenance.....	5-1
5-3	Removing the Chassis Cover	5-2
5-4	Installing Hard Drives.....	5-3
5-5	Installing the Motherboard	5-5
	Important Motherboard Installation Information	5-5
	Standoffs	5-6
	Installing and Removing the Heatsink(s)	5-7
	PCI Slot Setup	5-9
5-6	Installing the Air Shroud.....	5-10
	Installing the Air Shroud in a DP Chassis.....	5-10
	Installing the Air Shroud in a UP Chassis.....	5-11
	Checking the Airflow in the Chassis	5-11
	Installation Complete.....	5-11
5-7	System Fans and Blower Units.....	5-12
	System Fans (DP Chassis).....	5-12
	Blower Cooled Systems (UP Chassis)	5-12
	System Fan Tray Replacement.....	5-13
	Blower Unit Replacement	5-14
5-8	Power Supply	5-15
	Power Supply Failure.....	5-15
5-9	Replacing the Front LED Panel	5-17
	Removing the Front Bezel	5-17
	Replacing the Front LED Panel.....	5-18

Chapter 6 Rack Installation

6-1	Overview	6-1
6-2	Unpacking the System.....	6-1
6-3	Preparing for Setup.....	6-1
	Choosing a Setup Location.....	6-1
	Rack Precautions	6-2
	General Server Precautions.....	6-2
	Rack Mounting Considerations	6-3
	Ambient Operating Temperature	6-3
	Reduced Airflow	6-3
	Mechanical Loading	6-3
	Circuit Overloading.....	6-3

	Reliable Ground	6-3
6-4	Rack Mounting Instructions.....	6-4
	Identifying the Sections of the Rack Rails (Optional Item).....	6-4
	Installing the Inner Rail Extension	6-5
	Installing the Outer Rails to the Rack.....	6-6
	Installing the Chassis into a Rack.....	6-7
	Telco Post Style Rack Installation.....	6-8

Appendix A Cables, Screws, and Other Accessories

Appendix B Power Supply Specifications

Notes

Chapter 1

Introduction

1-1 Overview

Supermicro's SC513 1U chassis features a unique and highly-optimized design. The chassis is equipped with a high-efficiency power supply in a small form factor for optimized space efficiency.

The following chart lists model numbers and features currently available at the time of printing. For additional information visit the Supermicro Web site at www.supermicro.com

SC513 Chassis				
Model	CPU	HDD	I/O Slots	Power Supply
SC513L-420(B)	DP/UP	2x Fixed (2.5")	1x FH	420W
SC513L-410(B)	DP/UP	2x Fixed (2.5")	1x FH	410W DC
SC513F-350(B)	UP	1x Fixed (3.5")	1x FH	350W (Gold Level)
SC51F3-260(B)	UP	1x Fixed (3.5")	1x FH	260W
SC513L-260(B)	UP	1x Fixed (3.5")	1x FH	260W

Legend:

DP = Dual Processor Support

UP = Single Processor Support

FF = Full-height, Full-length

FH = Full-height, Half-length

LP = Low-profile

1-2 Chassis Features

The SC513 1U high-performance chassis supports a wide range of features. See the Chassis Components section of this manual for a list of features included in each of the SC513 models.

CPU

The SC513 chassis supports a DP and/or UP Xeon, Pentium D, P3/P4 processors. Please refer to the motherboard specifications pages on our web site for updates on supported processors.

I/O Expansion slots

Each version of the SC513 chassis includes one full height PCI slot located on the front of the chassis for easy access.

Dual Hard Drives

Some SC513 chassis models support a second hard disk drive. For more details, check the Chassis Components section of this manual or the Supermicro Website at www.supermicro.com.

1-3 Contacting Supermicro

Headquarters

Address: Super Micro Computer, Inc.
980 Rock Ave.
San Jose, CA 95131 U.S.A.

Tel: +1 (408) 503-8000

Fax: +1 (408) 503-8008

Email: marketing@supermicro.com (General Information)
support@supermicro.com (Technical Support)

Web Site: www.supermicro.com

Europe

Address: Super Micro Computer B.V.
Het Sterrenbeeld 28, 5215 ML
's-Hertogenbosch, The Netherlands

Tel: +31 (0) 73-6400390

Fax: +31 (0) 73-6416525

Email: sales@supermicro.nl (General Information)
support@supermicro.nl (Technical Support)
rma@supermicro.nl (Customer Support)

Asia-Pacific

Address: Super Micro Computer, Inc.
4F, No. 232-1, Liancheng Rd.
Chung-Ho 235, Taipei County
Taiwan, R.O.C.

Tel: +886-(2) 8226-3990

Fax: +886-(2) 8226-3991

Web Site: www.supermicro.com.tw

Technical Support:

Email: support@supermicro.com.tw

Tel: 886-2-8226-1900

1-4 Returning Merchandise for Service

A receipt or copy of your invoice marked with the date of purchase is required before any warranty service will be rendered. You can obtain service by calling your vendor for a Returned Merchandise Authorization (RMA) number. When returning to the manufacturer, the RMA number should be prominently displayed on the outside of the shipping carton, and mailed prepaid or hand-carried. Shipping and handling charges will be applied for all orders that must be mailed when service is complete.

For faster service, RMA authorizations may be requested online (<http://www.supermicro.com/support/rma/>).

Whenever possible, repack the chassis in the original Supermicro carton, using the original packaging material. If these are no longer available, be sure to pack the chassis securely, using packaging material to surround the chassis so that it does not shift within the carton and become damaged during shipping.

This warranty only covers normal consumer use and does not cover damages incurred in shipping or from failure due to the alteration, misuse, abuse or improper maintenance of products.

During the warranty period, contact your distributor first for any product problems.

Chapter 2

System Safety

2-1 Overview

This chapter provides a quick setup checklist to get your chassis up and running. Following the steps in order given should enable you to have your chassis set up and operational within a minimal amount of time. This quick setup assumes that you are an experienced technician, familiar with common concepts and terminology.

2-2 Warnings and Precautions

You should inspect the box the chassis was shipped in and note if it was damaged in any way. If the chassis itself shows damage, file a damage claim with carrier who delivered your system.

Decide on a suitable location for the rack unit that will hold that chassis. It should be situated in a clean, dust-free area that is well ventilated. Avoid areas where heat, electrical noise and electromagnetic fields are generated.

You will also need it placed near at least one grounded power outlet. When configured, the SC513 chassis includes one power supply.

2-3 Preparing for Setup

The SC513 chassis includes a set of rail assemblies, including mounting brackets and mounting screws you will need to install the systems into the rack. Please read this manual in its entirety before you begin the installation procedure.

2-4 Electrical Safety Precautions

Basic electrical safety precautions should be followed to protect yourself from harm and the SC513 from damage:

- Be aware of the locations of the power on/off switch on the chassis as well as the room's emergency power-off switch, disconnection switch or electrical outlet. If an electrical accident occurs, you can then quickly remove power from the system.
- Do not work alone when working with high-voltage components.

- Power should always be disconnected from the system when removing or installing main system components, such as the serverboard, memory modules and the DVD-ROM and floppy drives (not necessary for hot-swappable drives). When disconnecting power, you should first power down the system with the operating system and then unplug the power cords from all the power supply modules in the system.
- When working around exposed electrical circuits, another person who is familiar with the power-off controls should be nearby to switch off the power, if necessary.
- Use only one hand when working with powered-on electrical equipment. This is to avoid making a complete circuit, which will cause electrical shock. Use extreme caution when using metal tools, which can easily damage any electrical components or circuit boards they come into contact with.
- Do not use mats designed to decrease electrostatic discharge as protection from electrical shock. Instead, use rubber mats that have been specifically designed as electrical insulators.
- The power cord must include a grounding plug and must be plugged into a grounded electrical outlet.
- Serverboard battery: CAUTION - There is a danger of explosion if the onboard battery is installed upside down, which will reverse its polarities This battery must be replaced only with the same or an equivalent type recommended by the manufacturer. Dispose of used batteries according to the manufacturer's instructions.
- DVD-ROM laser: CAUTION - This server may have come equipped with a DVD-ROM drive. To prevent direct exposure to the laser beam and hazardous radiation exposure, do not open the enclosure or use the unit in any unconventional way.

2-5 General Safety Precautions

- Keep the area around the chassis clean and free of clutter.
- Place the chassis top cover and any system components that have been removed away from the system or on a table so that they won't accidentally be stepped on.
- While working on the system, do not wear loose clothing such as neckties and unbuttoned shirt sleeves, which can come into contact with electrical circuits or be pulled into a cooling fan.
- Remove any jewelry or metal objects from your body, which are excellent metal conductors that can create short circuits and harm you if they come into contact with printed circuit boards or areas where power is present.
- After accessing the inside of the system, close the system back up and secure it to the rack unit with the retention screws after ensuring that all connections have been made.

2-6 System Safety

Electrostatic discharge (ESD) is generated by two objects with different electrical charges coming into contact with each other. An electrical discharge is created to neutralize this difference, which can damage electronic components and printed circuit boards. The following measures are generally sufficient to neutralize this difference before contact is made to protect your equipment from ESD:

- Do not use mats designed to decrease electrostatic discharge as protection from electrical shock. Instead, use rubber mats that have been specifically designed as electrical insulators.
- Use a grounded wrist strap designed to prevent static discharge.
- Keep all components and printed circuit boards (PCBs) in their antistatic bags until ready for use.
- Touch a grounded metal object before removing any board from its antistatic bag.

- Do not let components or PCBs come into contact with your clothing, which may retain a charge even if you are wearing a wrist strap.
- Handle a board by its edges only; do not touch its components, peripheral chips, memory modules or contacts.
- When handling chips or modules, avoid touching their pins.
- Put the serverboard and peripherals back into their antistatic bags when not in use.
- For grounding purposes, make sure your computer chassis provides excellent conductivity between the power supply, the case, the mounting fasteners and the serverboard.

Chapter 3

Chassis Components

3-1 Overview

This chapter describes the most common components included with your chassis. Some components listed may not be included or compatible with your particular chassis model. For more information, see the installation instructions detailed later in this manual.

3-2 Components

Chassis

Depending on the model, the SC513 chassis may include at least one fixed hard drive and two USB ports. For the latest shipping lists, visit our Web site at: <http://www.supermicro.com>.

Fans and Blower Units

The SC513 model chassis accepts either a tray holding three system fans (DP models) or a blower unit (UP models). These cooling systems are powered by the motherboard.

Mounting Rails

The SC513 can be placed in a rack for secure storage and use. To set up your rack, follow the step-by-step instructions included in this manual. See the Rack Installation section of this manual for details.

Power Supply

Each SC513 chassis model includes a high-efficiency power supply rated at 260, 350, 410 (DC) or 420 Watts. In the unlikely event your power supply fails, replacement is simple and can be done without tools.

Air Shroud

Air shrouds are shields, usually plastic, that funnel air directly to where it is needed. Always use the air shroud included with your chassis.

3-3 Where to get Replacement Components

Although not frequently, you may need replacement parts for your system. To ensure the highest level of professional service and technical support, we strongly recommend purchasing exclusively from our Supermicro Authorized Distributors/System Integrators/Resellers. A list of Supermicro Authorized Distributors/System Integrators/Reseller can be found at: <http://www.supermicro.com>. Click the Where to Buy link.

Chapter 4

System Interface

4-1 LED Panel Overview

There are LEDs on the control panel and on the drive carriers to keep you constantly informed of the overall status of the system, as well as the activity and health of specific components. Most SC513 models have two buttons on the chassis control panel: a reset button and an on/off switch. This chapter explains the meanings of all LED indicators and the appropriate responses you may need to take.

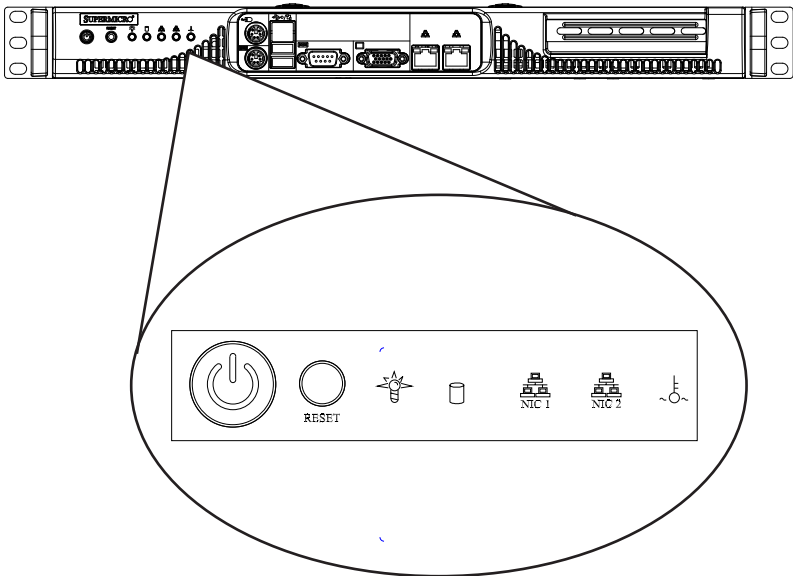
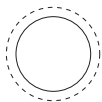

Figure 4-1: Chassis LED and Buttons

4-2 Control Panel Buttons

There are two push-buttons located on the front of the chassis. These are a reset button and a power on/off button.



- **Reset:** The reset button is used to reboot the system.



- **Power:** The main power switch is used to apply or remove power from the power supply to the server system. Turning off system power with this button removes the main power but keeps standby power supplied to the system. Therefore, you must unplug system before servicing.

4-3 Control Panel LEDs

The control panel located on the front of the SC513 chassis has five LEDs. These LEDs provide you with critical information related to different parts of the system. This section explains what each LED indicates when illuminated and any corrective action you may need to take.



- **Power:** Indicates power is being supplied to the system's power supply units. This LED should normally be illuminated when the system is operating.



- **HDD:** Indicates hard drive activity when flashing.



- **NIC2:** Indicates network activity on GLAN2 when flashing.



- **NIC1:** Indicates network activity on GLAN1 when flashing.



- **Overheat/Fan Fail:** When this LED flashes it indicates a fan failure. When continuously on (not flashing) it indicates an overheat condition, which may be caused by cables obstructing the airflow in the system or the ambient room temperature being too warm. Check the routing of the cables and make sure all fans are present and operating normally. You should also check to make sure that the chassis covers are installed. Finally, verify that the heatsinks are installed properly. This LED will remain flashing or on as long as the overheat condition exists.

4-4 I/O Panel Overview

The SC513 chassis has an I/O panel located on the front of the chassis for easy access. This is a fixed I/O panel and the motherboard used in the SC513 chassis must be compatible with this I/O panel. For details on the motherboards supported for the SC513 chassis, visit the Supermicro Web site at <http://www.supermicro.com/products/chassis/1U/?chs=513>

The SC513 fixed I/O panel includes mouse and keyboard ports, a dedicated LAN port, two USB ports, two COM ports, two LAN ports and one optional parallel port.

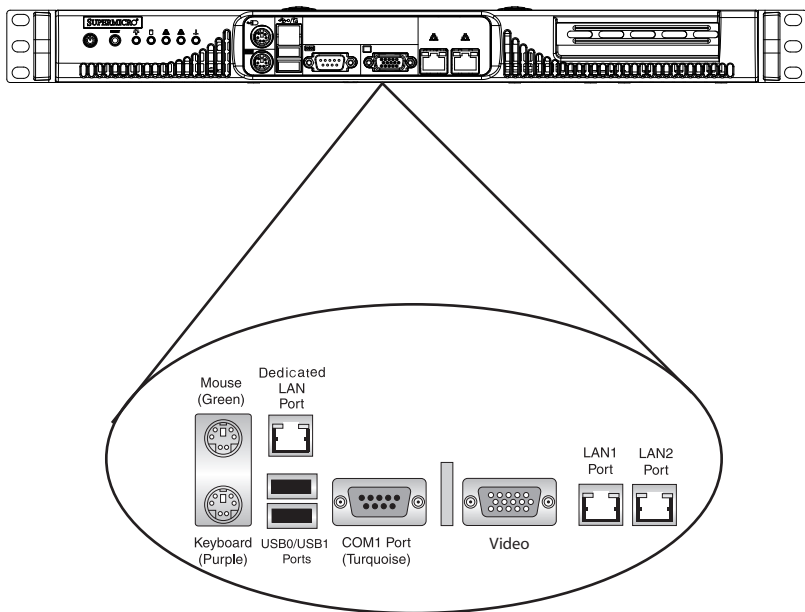

Figure 4-2: Front I/O Panel

Chapter 5

Chassis Setup and Maintenance

5-1 Overview

This chapter covers the steps required to install components and perform maintenance on the chassis. The only tools you will need to install components and perform maintenance are a Phillips head and a flathead screwdriver. Print this page to use as a reference while setting up your chassis.

5-2 Installation Procedures

Removing the Chassis Cover

Installing the Hard Drive

Installing the Motherboard (Includes installing standoffs, heatsink(s) and PCI slot setup)

Installing the Air Shroud

General Maintenance

Systems Fans and Blower Units

Power Supply

Replacing the Front LED Panel



Certain motherboards and heatsinks may not be compatible with this chassis. Before installation, review the motherboard installation procedures in this chapter.



Review the warnings and precautions listed in the manual before setting up or servicing this chassis. These include information in Chapter 2: System Safety and the warning/precautions listed in the setup instructions.

5-3 Removing the Chassis Cover

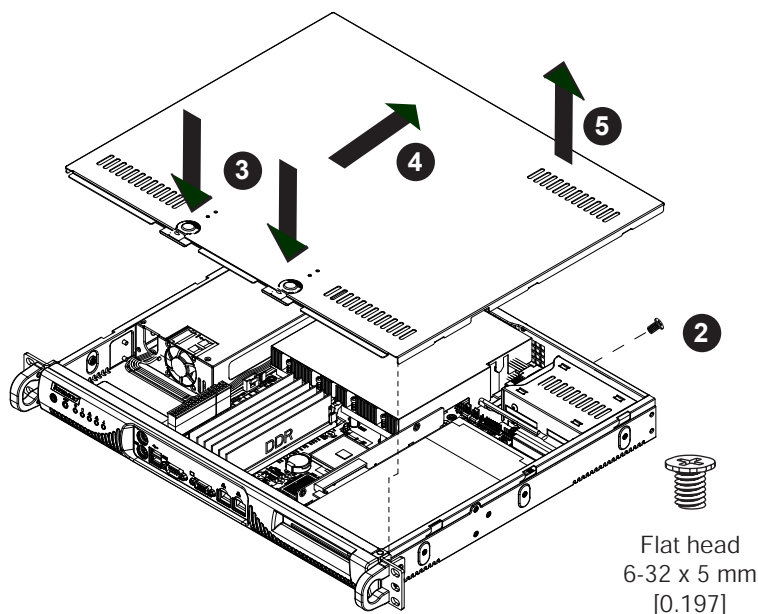

Figure 5-1: Removing the Chassis Cover

Removing the Chassis Cover

1. Disconnect the chassis from any power source.
2. Remove the screw holding the chassis cover in place at the rear of the chassis.
3. Simultaneously press the release buttons front of the chassis cover.
4. Slide the cover toward the rear of the chassis.
5. Lift the cover up and off the chassis.



Warning: Except for short periods of time, do **NOT** operate the server without the cover in place. The chassis cover must be in place to allow proper airflow and prevent overheating.

5-4 Installing Hard Drives

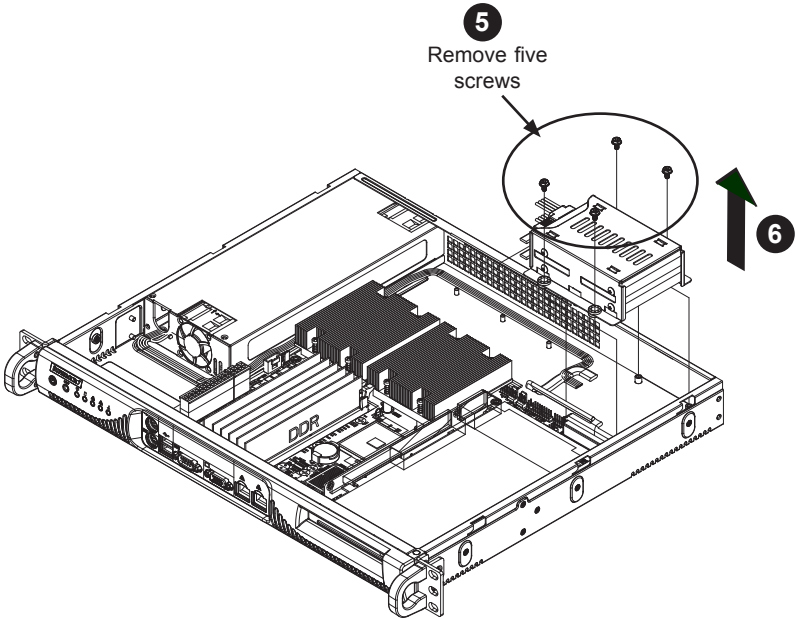

Figure 5-2: Removing the CD-ROM Drive to Access the Hard Drive
Installing a Hard Drive

1. Disconnect the chassis from any power source.
2. Open the chassis cover as described on the previous page.
3. Lift the air shroud up and out of the chassis.
4. Remove the fan tray or blower as described in section 5-7 of this manual.
5. Remove the five screws securing the hard drive cage to the floor of the chassis and set them aside for later use.
6. Lift the hard drive cage up and out of the chassis



Warning! Enterprise level hard disk drives are recommended for use in Supermicro chassis and servers. For information on recommended HDDs, visit the Supermicro Web site at <http://www.supermicro.com/products/nfo/storage.cfm>

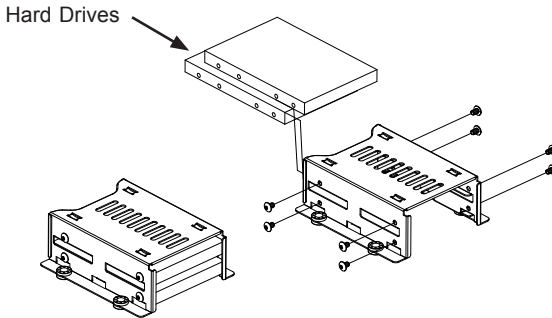

Figure 5-3: Adding the Hard Drive

7. Secure the hard drives into the hard drive cage using the eight screws provided.

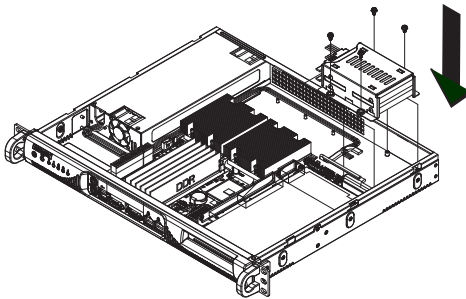

Figure 5-4: Adding a Second Hard Drive

8. Place the hard drive cage in the chassis as illustrated and secure it using the five screws which were previously set aside.

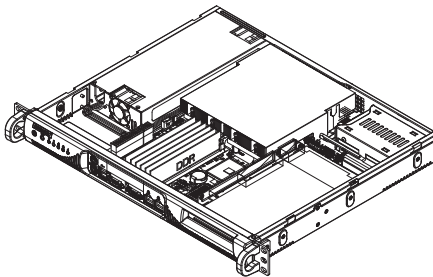

Figure 5-5: Hard Drive Cage in Place

9. Connect the cabling to the hard drive and replace the fan tray or blower and the air shroud.

5-5 Installing the Motherboard

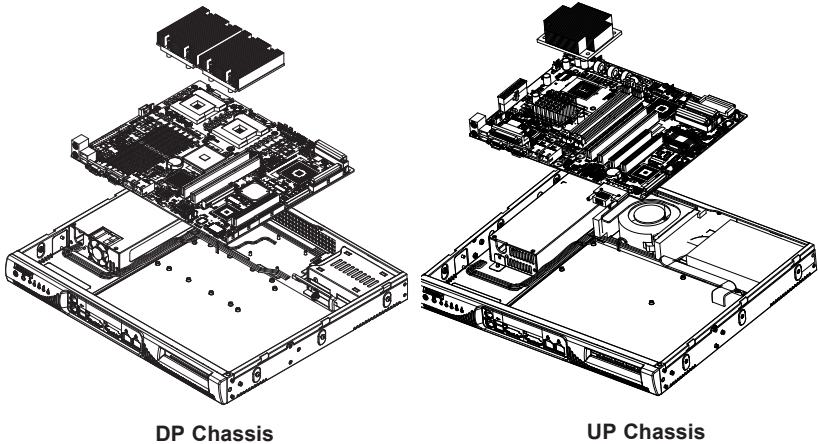

Figure 5-6 : The SC513 Backplate (I/O Shield)

Important Motherboard Installation Information

The installation of the motherboard, heatsink(s) and cooling systems are different in DP and UP model chassis. Before installing the motherboard, be aware of the following:

I/O Panel

The SC513 chassis has a fixed front I/O panel, which holds the motherboard ports in place. Your motherboard must match the SC513 I/O panel. If your motherboard does not match, you must choose a different motherboard.

Heatsinks

Some compatible motherboards require one or two heatsinks to lower the temperature of the components. Heatsinks for the SC513 chassis must be rated for 1U in height or less.

Standoffs

Standoffs prevent short circuits by securing space between the motherboard and the chassis surface. The SC513 chassis includes permanent standoffs in locations used by most motherboards. These standoffs accept the rounded Phillips head screws included in the SC513 accessories packaging.

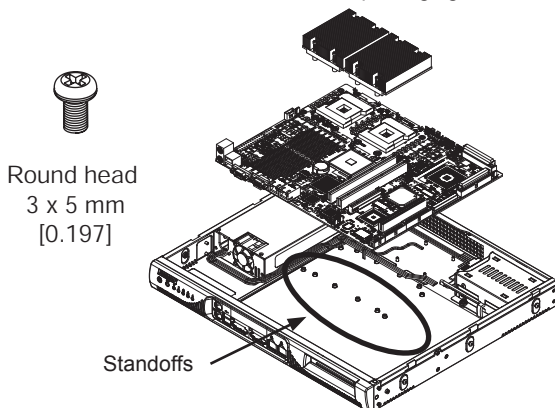

Figure 5-7: Motherboard Standoffs

Installing the Motherboard

1. Review the documentation that came with your motherboard. Become familiar with component placement, requirements, precautions, and cable connections.
2. Disconnect the chassis from any power source.
3. Compare the mounting holes in the motherboard and the mounting holes in the chassis and add or remove standoffs as required.
4. Align the motherboard with the chassis standoffs and carefully, place the motherboard in the chassis. Make sure rear ports line up with the I/O shield.
5. Secure the motherboard to the chassis. Do not exceed eight pounds of torque when tightening down the motherboard.
6. Secure the CPU(s), heatsinks, and other components to the motherboard as described in the motherboard documentation.
7. Connect the cables between the motherboard, backplane, chassis, front panel, and power supply.

Installing and Removing the Heatsink(s)

Heatsinks transfer heat away from the motherboard. The heatsinks on the SC513 chassis vary with DP and UP models. #SNK-P0007 is used on DP systems, #SNKP0011 is used on UP systems. CAUTION! Heatsinks are heavy and must be handled with care.

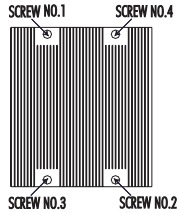

Figure 5-8: Installing the Heatsink

Heatsink Installation

1. Disconnect the chassis from any power source.
2. Do not apply thermal grease to the heatsink or CPU die. The required amount of grease has already been applied.
3. Screw in two screws which are positioned diagonally from one another, for example, Screw No.1 and Screw No.2 as shown above. Tighten the screws only until they are snug. Do not fully tighten the screws to avoid possible damage to the CPU.
4. Complete the installation by fully tightening all four screws.

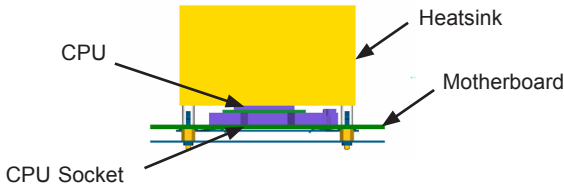

Figure 5-9: Heatsink Installed

Removing the Heatsink

1. Unscrew and remove the heatsink screws from the motherboard in the sequence shown on the right of figure 5-8 above.

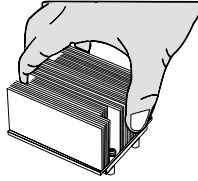

Figure 5-10: Placing the Heatsink

2. Hold the the heatsink as shown in the illustration above. Gently wiggle the heatsink to loosen it from the CPU. Do not use excessive force when removing the heatsink!
3. Carefully lift the heatsink from the CPU socket.
4. Clean the surface of the CPU and the heatsink to remove the thermal grease.
5. Reapply thermal grease before re-installing.

PCI Slot Setup

SC513 chassis includes a slot for one full height/full length expansion card and a riser card. The riser card allows the expansion card to fit within the small 1U form.

The expansion card slot does not require a screw to hold the card in place.

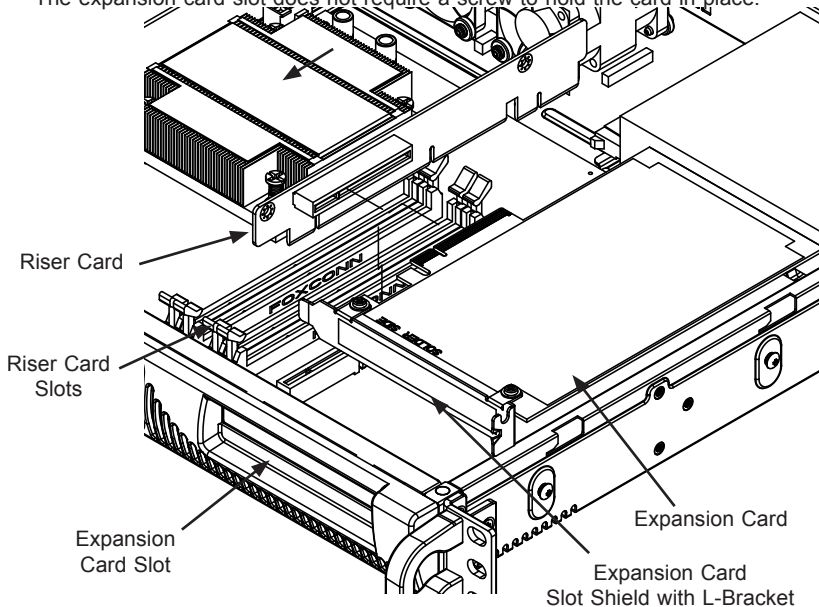

Figure 5-11: Installing the Expansion Card

Installing Expansion Cards

1. Disconnect the chassis from any power source, unplug the power supply, lay the chassis on a flat surface and open the cover.
2. Slide the clip upward which secures the temporary expansion card shield in the expansion card slot on the inside of the chassis.
3. Slide the expansion card slot shield toward the right side of the chassis and remove the shield.
4. Secure the riser card into the riser card slot on the motherboard.
5. Slide the expansion card slot shield with the L-bracket into the expansion card slot and into the port on the riser card.
6. Replace the PCI slot clip to secure the expansion card to the chassis.

5-6 Installing the Air Shroud

The air shroud helps cool the chassis by directing heated air through the rear of the chassis. When installing the air fan, be aware of the following:

- The air shroud is designed to fit within the chassis. The sides of the air shroud should remain straight in relation to the top. Do not fold or bend the air shroud.

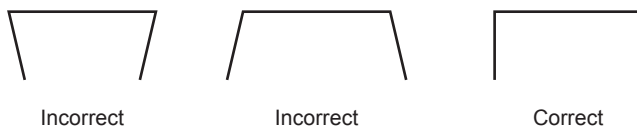

Figure 5-9: Air Shroud Placement

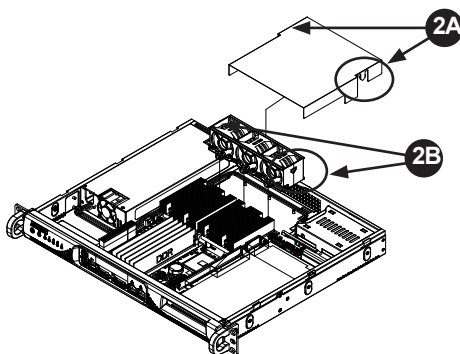

Figure 5-12: Installing the Air Shroud in a DP Chassis

Installing the Air Shroud in a DP Chassis

DP Chassis - Installing The Air Shroud

1. Confirm that the air shroud matches your chassis model.
2. Place the air shroud in the chassis, aligning the mounting tabs on the system fan with the corresponding holes on the floor of the chassis.
3. Align the two clips on the air shroud (2A) with the holes on the system fan tray (2B).
4. Insert the clips on the air shroud into the holes on the system fan tray.

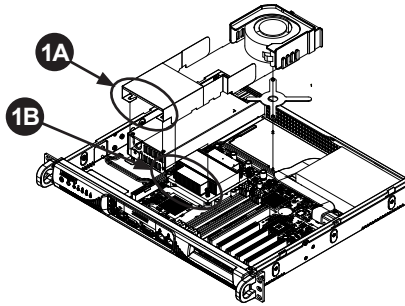

Figure 5-13: Installing the Air Shroud in a UP Chassis

Installing the Air Shroud in a UP Chassis

UP Chassis - Installing The Air Shroud

1. Align the two slotted holes on the air shroud (1A) with the two screws on the heatsink (1B). Place the air shroud on top of the heatsink by sliding the two slotted holes over the two screws on the heatsink.

Checking the Airflow in the Chassis

1. Make sure there are no objects to obstruct airflow in and out of the server.
2. Do not operate the server without drives or drive trays in the drive bays. Use only recommended server parts.
3. Make sure no wires or foreign objects obstruct air flow through the chassis. Pull all excess cabling out of the airflow path or use shorter cables.

The control panel LEDs inform you of system status. See “Chapter 3: System Interface” for details on the LEDs and the control panel buttons.

Installation Complete

In most cases, the chassis power supply and fans are pre-installed. If it is necessary to install fans, continue to the Systems Fans and Blower Units section of this chapter. If the chassis will be installed into a rack, continue to the next chapter for rack installation instructions.

5-7 System Fans and Blower Units

The SC513 chassis comes equipped with either a single blower unit or a set of system fans to provide internal cooling for the system.

System Fans (DP Chassis)

Three heavy duty fans provide cooling for the chassis. These fans circulate air through the chassis which lowers temperature within the chassis.

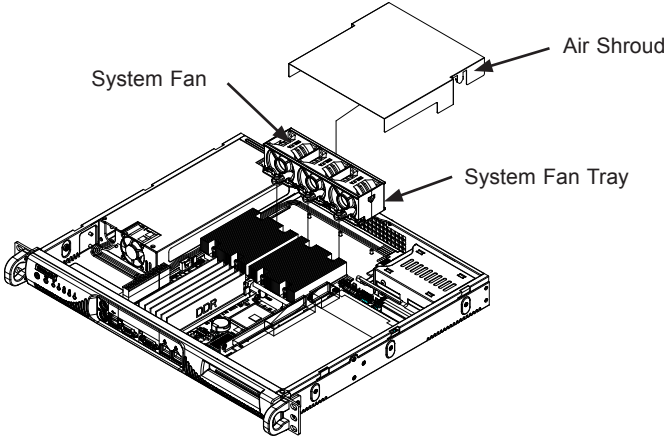

Figure 5-14: Identifying System Fans

Blower Cooled Systems (UP Chassis)

Blower-cooled chassis utilize a single blower unit for cooling. The blower circulates air over within the chassis, lowering the internal temperature.

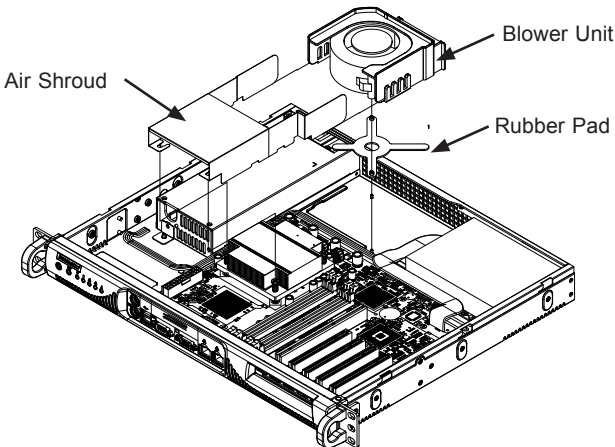

Figure 5-15: Identifying a Blower Unit

System Fan Tray Replacement

Removing the System Fan Tray

1. Power-down the system and remove the chassis from any power source.
2. Disconnect each fan from the motherboard.
3. Carefully lift the air shroud's tabs out of the mounting holes on each side of the system fan tray.
4. Remove the three screws securing the system fan tray to the floor of the chassis, setting aside the screws and rubber grommets for later use.
5. Lift the system fan tray up and out of the chassis.

Replacing Individual System Fans

Fans can be replaced individually without removing the system fan tray. There is no need to power down the system when replacing a system fan.

Replacing System Fans

1. If necessary, open the chassis while the power is running to determine which fan has failed. (Never run the server for an extended period of time with the chassis open.)
2. Remove the failed fan's power cord from the serverboard.
3. Lift the failed fan completely from the chassis.
4. Place the new fan into the vacant space. Make sure the arrows on the top of the fan (indicating air direction) point in the same direction as the arrows on the other fan(s).
5. Confirm that the fan is working properly and replace the chassis cover..

Installing the System Fan Tray

1. Align the three mounting tabs on the system fan tray with the mounting holes on the floor of the chassis, placing the rubber grommets previously set aside between the chassis and the system fan tray.
2. Secure the system fan tray to the floor of the chassis using the screws provided.

3. Attach the air shroud as described in section 5-6.
4. Reconnect the wiring to the fans and power-up the system.

Blower Unit Replacement

Installing the Blower

1. Power down the system and remove the chassis from any power source.
2. Disconnect the blower from the motherboard.
3. Remove the air shroud from the blower as described in section 5-6.
4. Carefully lift the air shroud, blower and the rubber pad up and out of the chassis.
5. Replace the rubber pad by placing the two holes in the pad over the posts in the floor of the chassis.
6. Place the blower over the rubber pad and posts.
7. Clip the air shroud onto the front of the blower.
8. Reconnect the blower to the motherboard

5-8 Power Supply

Depending on your chassis model the SC513 chassis has a 260, 350, 410 or 420 Watt power supply. This power supply is auto-switching capable. This enables it to automatically sense and operate at a 100V to 240V input voltage. An amber light will be illuminated on the power supply when the power is off. An illuminated green light indicates that the power supply is operating.

Power Supply Failure

The SC513 series chassis has one power supply. In the unlikely event that the power supply unit fails, the system will shut down and you will need to replace it.

Replacement units can be ordered directly from Supermicro (see contact information in the preface) or an authorized reseller.

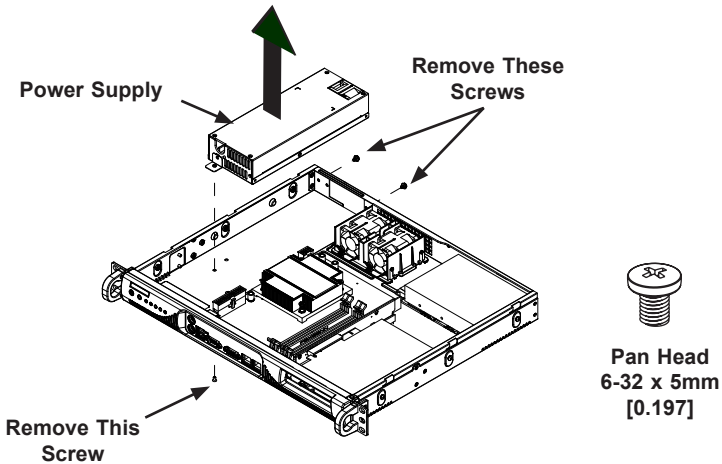

Figure 5-16: Removing the Power Supply

Replacing the Power Supply

1. Disconnect the power cord from the from the chassis to ensure that the unit is not accidentally plugged in.
2. Place the chassis on a stable hard surface and remove the chassis cover.
3. Disconnect the power supply from the motherboard and other chassis components.
4. Remove the screws securing the power supply. Two screws are in the back of the chassis and one underneath. Retain the screws and the internal brace that connects the power supply to the chassis from underneath.

5. Pull the power supply out of the chassis.
6. Place the new power supply into the chassis and secure the power supply using the three screws and internal brace.
7. Connect the power supply to the motherboard and other chassis components.
8. Connect the power cord to the power supply and power up the chassis/server.
9. Once you confirm that the power supply has been installed correctly, replace the chassis cover.

5-9 Replacing the Front LED Panel

In the unlikely event that the chassis LED or buttons fail, the front panel can be replaced. Replacement parts can be ordered from Supermicro or an authorized reseller. Replacing the front LED panel requires that the bezel be removed from the front of the chassis.

Removing the Front Bezel

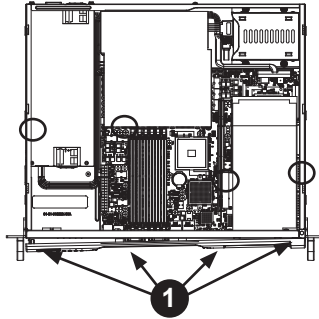

Figure 5-17: Front Bezel Release Tabs

Removing the Bezel

1. Locate the four front bezel release tabs on the front of the chassis.

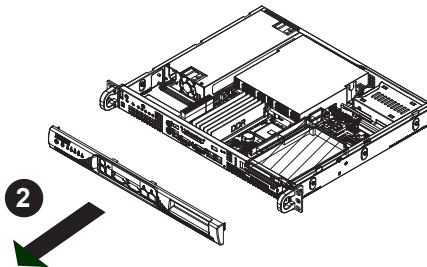

Figure 5-18: Removing the Front Bezel

2. Gently remove the bezel from the front of the chassis by pulling it forward as illustrated above.

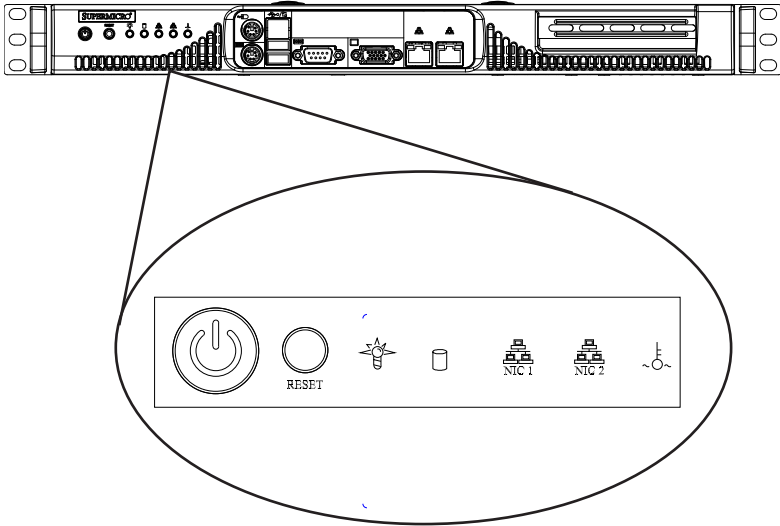

Figure 5-19: Replacing the LED Panel

Replacing the Front LED Panel

Replacing the LED Panel

1. Remove the front bezel as described in the previous section.
2. Disconnect the cord to the front panel.
3. Locate and remove the three screws holding the panel in place.
4. Install the new LED panel and secure the unit with three screws.
5. Reconnect the cables to the LED panel and if necessary, replace the hard drive.

Chapter 6

Rack Installation

6-1 Overview

This chapter provides a quick setup checklist to install the chassis into a rack.

6-2 Unpacking the System

You should inspect the box the chassis was shipped in and note if it was damaged in any way. If the chassis itself shows damage you should file a damage claim with the carrier who delivered it.

Decide on a suitable location for the rack unit that will hold your chassis. It should be situated in a clean, dust-free area that is well ventilated. Avoid areas where heat, electrical noise and electromagnetic fields are generated. You will also need it placed near a grounded power outlet. Be sure to read the Rack and Server Precautions in the next section.

6-3 Preparing for Setup

The box your chassis was shipped in should include two sets of rail assemblies, two rail mounting brackets and the mounting screws you will need to install the system into the rack. Please read this section in its entirety before you begin the installation procedure outlined in the sections that follow.

Choosing a Setup Location

- Leave enough clearance in front of the rack to enable you to open the front door completely (~25 inches).
- Leave approximately 30 inches of clearance in the back of the rack to allow for sufficient airflow and ease in servicing.
- This product is for installation only in a Restricted Access Location (dedicated equipment rooms, service closets and the like).



Warnings and Precautions!



Rack Precautions

- Ensure that the leveling jacks on the bottom of the rack are fully extended to the floor with the full weight of the rack resting on them.
- In single rack installation, stabilizers should be attached to the rack.
- In multiple rack installations, the racks should be coupled together.
- Always make sure the rack is stable before extending a component from the rack.
- You should extend only one component at a time - extending two or more simultaneously may cause the rack to become unstable.

General Server Precautions

- Review the electrical and general safety precautions that came with the components you are adding to your chassis.
- Determine the placement of each component in the rack *before* you install the rails.
- Install the heaviest server components on the bottom of the rack first, and then work up.
- Use a regulating uninterruptible power supply (UPS) to protect the server from power surges, voltage spikes and to keep your system operating in case of a power failure.
- Allow the hot plug hard drives and power supply modules to cool before touching them.
- Always keep the rack's front door and all panels and components on the servers closed when not servicing to maintain proper cooling.

Rack Mounting Considerations

Ambient Operating Temperature

If installed in a closed or multi-unit rack assembly, the ambient operating temperature of the rack environment may be greater than the ambient temperature of the room. Therefore, consideration should be given to installing the equipment in an environment compatible with the manufacturer's maximum rated ambient temperature (T_{mra}).

Reduced Airflow

Equipment should be mounted into a rack so that the amount of airflow required for safe operation is not compromised.

Mechanical Loading

Equipment should be mounted into a rack so that a hazardous condition does not arise due to uneven mechanical loading.

Circuit Overloading

Consideration should be given to the connection of the equipment to the power supply circuitry and the effect that any possible overloading of circuits might have on overcurrent protection and power supply wiring. Appropriate consideration of equipment nameplate ratings should be used when addressing this concern.

Reliable Ground

A reliable ground must be maintained at all times. To ensure this, the rack itself should be grounded. Particular attention should be given to power supply connections other than the direct connections to the branch circuit (i.e. the use of power strips, etc.).

6-4 Rack Mounting Instructions

This section provides information on installing the SC513 chassis into a rack unit with the rails provided. There are a variety of rack units on the market, which may mean the assembly procedure will differ slightly. You should also refer to the installation instructions that came with the rack unit you are using.

NOTE: The SC513F-280/350/410/520/600 chassis models are designed with a wider chassis. The rails for these chassis will fit a rack between 25.6" and 33.05" deep. The following shows how to mount these chassis to a standard rack.

Identifying the Sections of the Rack Rails (Optional Item)

The chassis package includes two rack rail assemblies in the rack mounting kit. Each assembly consists of two sections: an inner fixed chassis rail that secures directly to the server chassis, and an outer fixed rack rail that secures directly to the rack itself. The SC513F comes with "chassis handles", which allow the chassis to be mounted on generic rails.

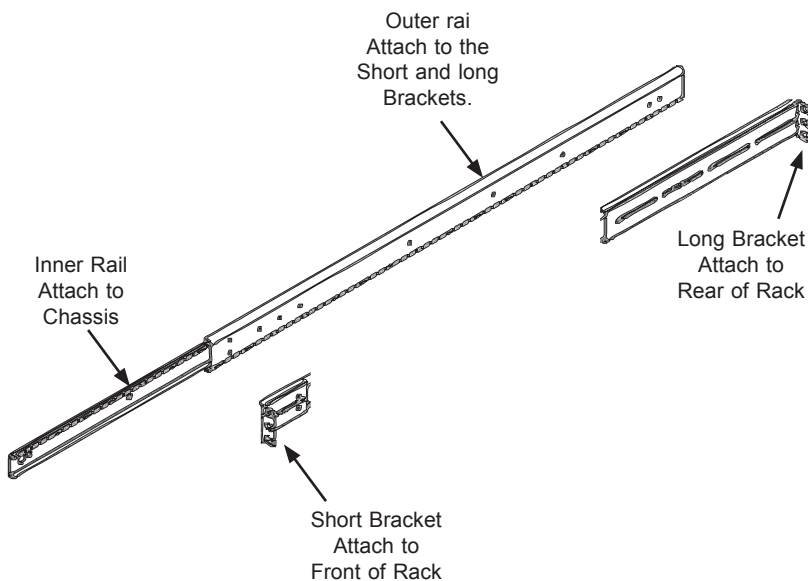

Figure 6-1: Identifying the Sections of the Rack Rails (Right side rail shown)

Installing the Inner Rail Extension

The SC513F includes chassis handles that you must remove before installing the rails.

Removing the Chassis Handles

1. Locate and remove the three screws holding the chassis ear in place.
2. Repeat step on with the other chassis ear.

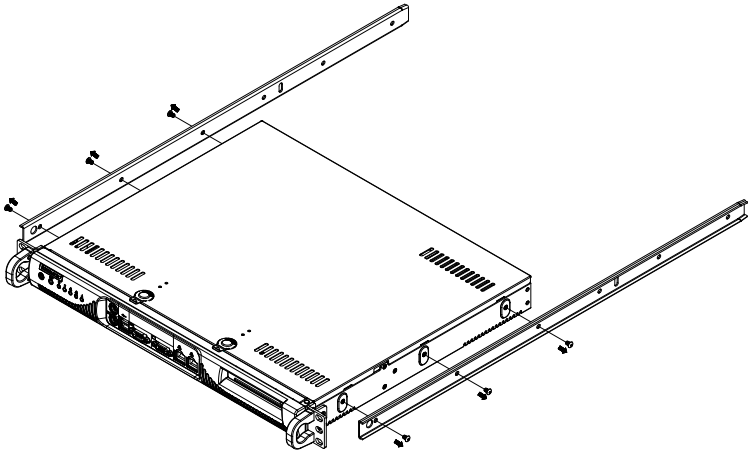

Figure 6-2: Installing Inner Rails to the Chassis

Installing the Inner Rails

1. Place the inner rail on the side of the chassis aligning the hooks of the chassis with the rail holes.
2. Slide the inner rail toward the front of the chassis to secure the rail in place.
3. Secure the inner rail to the chassis with three screws.
4. Repeat steps 1-3 for the other inner rail extension.

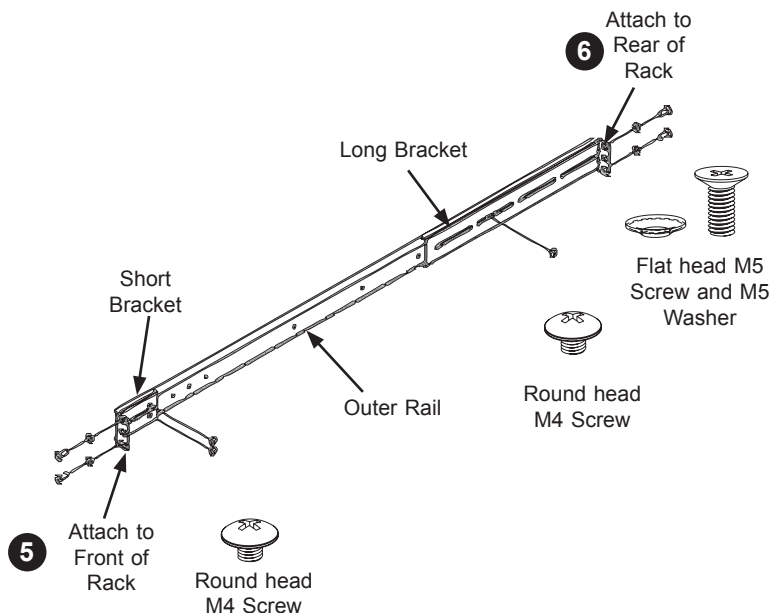

Figure 6-3: Assembling and Installing the Outer Rails

Installing the Outer Rails to the Rack

Installing the Outer Rails

1. Slide the short and long brackets on the outside of the outer rail. You must align the pins with the slides. Both bracket ends must face the same direction.
2. Adjust both the short and long brackets to the proper distance so that the rail fits snugly into the rack.
3. Secure the long bracket to outer rail with two M4 screws. Use a washer with each screw.
4. Secure the short bracket to the outer rail with two M4 screws. Use a washer with each screw.
5. Attach the front of the short bracket to the front of the rack using two M5 screws.
6. Attach the rear of the long bracket to the rear of the rack using two M5 screws.
7. Repeat steps 1-7 for the remaining outer rail.

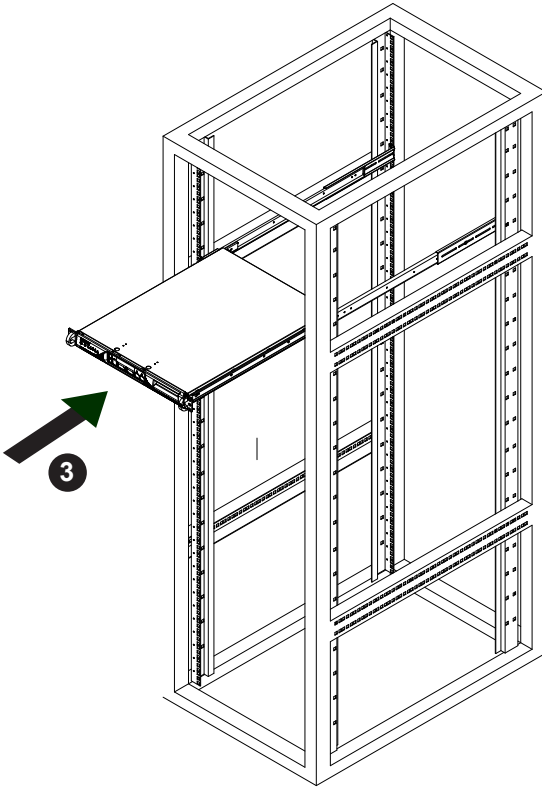

Figure 6-4: Installing the Chassis into a Rack

Installing the Chassis into a Rack

Installing the Chassis

1. Confirm that the inner rails are attached to the chassis and confirm that the outer rails are installed on the rack.
2. Align the inner rails on the chassis with the front of the outer rails on the rack.
3. Slide the chassis rails into the rack rails, keeping the pressure even on both sides (you may have to depress the locking tabs when inserting). When the server has been pushed completely into the rack, you should hear the locking tabs "click" into the locked position.
4. (Optional) Insert and tighten the thumbscrews that hold the front of the server to the rack.

Telco Post Style Rack Installation

The SC513.chassis rail system supports mounting in Telco or post style racks.

Instaling into a Telco Rack

1. Locate the pair of short brackets and one long brackets, the inner rail (attached to the chassis), and the outer rail.

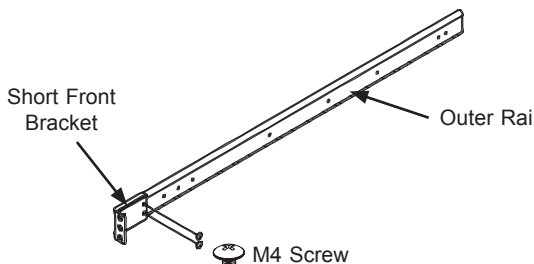

Figure 6-5: Attach the Short Front Bracket to the Outer Rail

2. Attach the short front bracket to the outer rail using two round head M4 screws.

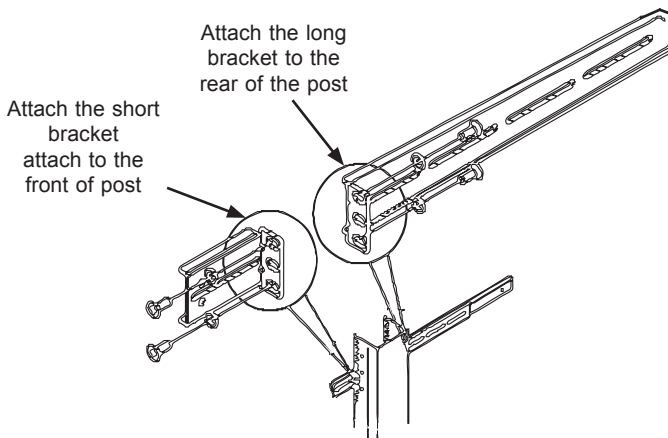

Figure 6-6: Attach the Short and Long Brackets to the Outer Post

3. Attach the remaining short bracket to the front of the post using two M5 screws and two M5 washers.
4. Attach the long bracket to the rear of the post using two M5 screws and two M5 washers.

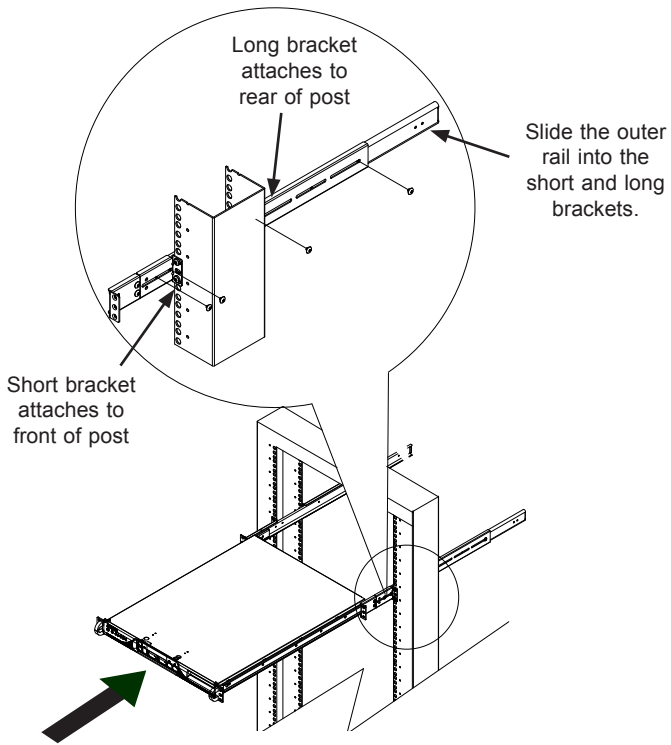

Figure 6-7: Installing the Chassis into a Telco Rack

5. Slide the outer rail through the short and long brackets.
6. Repeat steps 1 through 5 for the other side of the rack.
7. Align the inner rails on the chassis with the outer rails on the rack.
8. Slide the chassis into the rack.
9. Position the chassis to balance its weight evenly between the front and the rear of the rack.

Notes

Appendix A

Cables, Screws, and Other Accessories

A-1 Overview

This appendix lists supported cables for your chassis system. It only includes the most commonly used components and configurations. For more compatible cables, refer to the manufacturer of the motherboard you are using and our Web site at: www.supermicro.com.

A-2 Cables Included with SC513 Chassis

SC513L-420, SC513L-410,			
Part #	Type	Length	Description
CBL-0071	Cable		Front Panel Round Cable

SC513F-350			
Part #	Type	Length	Description
CBL-0087	Cable	20"	Front control cable 16 to 16 pin Ribbon
CBL-0260L		6'	US power cord 18 AWG

SC513F-260, SC513L-260			
Part #	Type	Length	Description
CBL-0087	Cable	20"	Front control cable 16 to 16 pin Ribbon

Extending Power Cables

Although Supermicro chassis are designed with to be efficient and cost-effective, some compatible motherboards have power connectors located in different areas.

To use these motherboards you may have to extend the power cables to the motherboards. To do this, use the following chart as a guide.

Power Cable Extenders		
Number of Pins	Cable Part #	Length
24-pin	CBL-0042	7.9"(20 CM)
20-pin	CBL-0059	7.9"(20 CM)
8-pin	CBL-0062	7.9"(20 CM)
4-pin	CBL-0060	7.9"(20 CM)

Front Panel to the Motherboard

The SC513 chassis includes a cable to connect the chassis front panel to the motherboard. If your motherboard uses a different connector, use the following list to find a compatible cable.

Front Panel to Motherboard Cable (Ribbon Cable)		
Number of Pins (Front Panel)	Number of Pins (Motherboard)	Cable Part #
16-pin	16-pin	CBL-0049
16-pin	20-pin	CBL-0048
20-pin	20-pin	CBL-0047
16-pin	varies*	CBL-0068
20-pin	varies*	CBL-0067

* Split cables: Use these cable if your motherboard requires several different connections from the front panel.

A-3 Chassis Screws

The chassis and accessory box include all the screws needed to set up your chassis. This section include descriptions of the most common screws used. Your chassis may not require all the parts listed.

M/B



Pan head
6-32 x 5 mm
[0.197]

HARD DRIVE



Flat head
6-32 x 5 mm
[0.197]

DVD-ROM CD-ROM FLOPPY DRIVE



Pan head
6-32 x 5 mm
[0.197]



Flat head
6-32 x 5 mm
[0.197]



Round head
3 x 5 mm
[0.197]



Round head
2.6 x 5 mm
[0.197]

RAIL



Flat head
M4 x 4 mm
[0.157]



Round head
M4 x 4 mm
[0.157]



Flat head
M5 x 12 mm [0.472]
Washer for M5



M/B STANDOFF



M/B standoff
6-32 to 6-32



M/B (CPU) standoff
M5 to 6-32

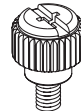

Thumb screw
6-32 x 5 mm [0.197]

Figure A-1: Chassis Screws

Notes

Appendix B

Power Supply Specifications

This appendix lists power supply specifications for your chassis system.

SC513F-260, SC513L-260 Chassis Model	
	260
MFR Part #	PWS-0055
Rated AC Voltage	100 - 240V 60 - 50Hz 4A Max
DC Output	5V + 3.3V ≤ 140W
+5V standby	2.0A
+12V	18.0A
+5V	25.0A
+3.3V	15.0A
-12V	1.0A

SC513F-350	
	350
MFR Part #	PWS-351-1H
Rated AC Voltage	100-240 V, 50-60 Hz, 4.2 - 1.8A
+5V standby	3A
+12V	29A
+5V	18A
+3.3V	15A

SC513F-410 Chassis Model	
	410
MFR Part #	PWS-0061
DC Voltage	Voltage Range = -36V to -72V Nominal Voltage = -48V Max Input Current = 18A @ -48V
DC Output	5V + 3.3V ≤ 180W
+5V	35.0A
+5V standby	3.0A
+12V	32.0A
-12V	0.5A
+3.3V	20.0A

SC513L-420 Chassis Model	
	410
MFR Part #	PWS-0053
AC Voltage	100 - 240V 60-50Hz 7 Amp
DC Output	5V + 3.3V ≤ 160W
+5V	30.0A
+5V standby	2.0A
+12V	15.0A
+12V₂	15.0A
+12V₃	18.0A
-12V	1.0A
+3.3V	20.0A

Notes

Disclaimer (cont.)

The products sold by Supermicro are not intended for and will not be used in life support systems, medical equipment, nuclear facilities or systems, aircraft, aircraft devices, aircraft/emergency communication devices or other critical systems whose failure to perform be reasonably expected to result in significant injury or loss of life or catastrophic property damage. Accordingly, Supermicro disclaims any and all liability, and should buyer use or sell such products for use in such ultra-hazardous applications, it does so entirely at its own risk. Furthermore, buyer agrees to fully indemnify, defend and hold Supermicro harmless for and against any and all claims, demands, actions, litigation, and proceedings of any kind arising out of or related to such ultra-hazardous use or sale.