

TANDBERG DATA

Securing your Information



LTO HH SCSI Tape Drive

User Guide

Part Number 433867-01 - June 2008

www.tandbergdata.com

COPYRIGHT

© Copyright 2008 Tandberg Data ASA.

All rights reserved. This item and the information contained herein are the property of Tandberg Data ASA. No part of this document may be reproduced, transmitted, transcribed, stored in a retrieval system, or translated into any language or computer language in any form or by any means, electronic, mechanical, magnetic, optical, chemical, manual, or otherwise, without the express written permission of Tandberg Data ASA, Økernveien 94, 0579 Oslo, Norway.

DISCLAIMER: Tandberg Data Corporation makes no representation or warranties with respect to the contents of this document and specifically disclaims any implied warranties of merchantability or fitness for any particular purpose. Further, Tandberg Data Corporation reserves the right to revise this publication without obligation of Tandberg Data Corporation to notify any person or organization of such revision or changes.

TRADEMARK NOTICES: Tandberg Data Corporation trademarks: Tandberg Data, Exabyte, the Exabyte Logo, EZ17, M2, SmartClean, VXA, and VXAtape are registered trademarks; MammothTape is a trademark; SupportSuite is a service mark. Other trademarks: Linear Tape-Open, LTO, the LTO Logo, Ultrium and the Ultrium Logo are trademarks of HP, IBM, and Quantum in the US and other countries. All other product names are trademarks or registered trademarks of their respective owners.

Note: The most current information about this product is available at Tandberg Data's web site (<http://www.tandbergdata.com>).

PART NUMBER

433867-01



Contents

About this guide	VII
Intended audience	VII
Document conventions and symbols	VII
Technical support	VIII
Product warranties	VIII
1 Before you start	9
Supported models	9
Which operating systems are supported?	9
How do I connect the drive to my server?	9
Internal drives	10
External drives	10
Why is the SCSI bus type important?	10
Your LTO tape drive	12
Power specifications	12
Usage models	12
Other usage models	14
Drivers	14
Backup software	15
Enabling encryption (LTO-4 only)	15
2 Installing an internal LTO tape drive	17
Check the internal drive's SCSI ID	17
Prepare mounting bay	18
Attach mounting hardware	19
Install drive	20
Attach power and SCSI cables	21
Where should the SCSI terminator be?	22
Secure the drive	23
Reboot the server	24
3 Installing an external LTO tape drive	25
Check the external drive's SCSI ID	25
Connect the SCSI cable	26
Does the tape drive need a terminator?	27
Connect the power cable	28
Reboot the server	28
4 Verify installation	29
5 Understanding the LEDs	31

Front view of LTO tape drive with LEDs	31
Understanding LED sequences	31
6 Operating your tape drive	35
Loading a cartridge	35
Unloading a cartridge	36
Removing power from the drive	36
7 Use the correct media	37
Cartridges	37
Cleaning cartridges	37
Data cartridges	37
WORM data cartridges	38
LTO-4 tape drives and encryption	38
When should I use encryption?	39
How do I enable encryption?	39
When will I be asked to enter the key?	39
What happens if I don't remember the key?	39
Does encryption affect tape drive performance?	39
Does the tape drive encrypt media in an earlier Ultrium format?	40
Where can I get more information?	40
Write protecting cartridges	40
Cleaning the tape drive	41
Handling cartridges	41
Operating and storage environment	42
8 Troubleshooting	43
General Procedure	43
Optimizing performance	44
Is the tape drive on a dedicated SCSI bus?	45
Can your system deliver the required performance?	45
Problems with cartridges	46
The cartridge is jammed	47
The drive will not accept the cartridge (or ejects it immediately)	47
A SCSI configuration guide	49
SCSI in LTO devices	49
Daisy chaining devices	49
SCSI terminology	50
Setting up the SCSI bus	50
SCSI ID numbers	50
Identifying SCSI IDs	51
Setting the SCSI ID on LTO drives	51
SCSI termination	51
Internal drives	52
External drives	52
SCSI cables	54
Cable length	54
Cable quality	54
With internal devices	54
With external devices	55
Note on SE and LVD interfaces	55
Index	57



Figures

Figure 1-1	Front view of half-height LTO external tape drive	12
Figure 1-2	Usage model	13
Figure 2-1	Checking the SCSI ID	18
Figure 2-2	Attaching mounting rails	20
Figure 2-3	Attaching locating screws	20
Figure 2-4	Installing tape drive	21
Figure 2-5	Connecting power and SCSI cables	22
Figure 2-6	Securing drive, mounting hardware used	23
Figure 2-7	Securing drive, no mounting hardware used	24
Figure 3-1	Setting the SCSI ID	26
Figure 3-2	Connecting the SCSI cable	27
Figure 3-3	Connecting the power cable	28
Figure 5-1	Front view of external tape drive	31
Figure 6-1	Inserting a cartridge	35
Figure 6-2	Ejecting a cartridge	36
Figure 7-1	Write protecting a cartridge	41
Figure A-1	SCSI termination in internal drives	52
Figure A-2	SCSI termination on a single LTO tape drive	53
Figure A-3	SCSI termination in daisy-chained external drives	54



Tables

Table 1	Document conventions	VII
Table 1-1	Supported SCSI bus types	11
Table 1-2	Recommended usage models	14
Table 5-1	LED sequences	32
Table 5-2	Rear panel LED sequences (external tape drives only) . . .	34
Table 7-1	Data cartridge compatibility	38
Table 8-1	Environmental specifications for LTO tape drives	43

ABOUT THIS GUIDE

This guide provides information about:

- ▶ Installing the LTO SCSI tape drive
- ▶ Using the LTO SCSI tape drive
- ▶ Troubleshooting the LTO SCSI tape drive

INTENDED AUDIENCE

This guide is intended for users who install, operate and maintain the LTO tape drive.

DOCUMENT CONVENTIONS AND SYMBOLS

Table 1 Document conventions

Convention	Element
Blue text: Table 1 on page VII	Cross-reference links and e-mail addresses
Blue, underlined text: http://www.tandbergdata.com	website addresses
Bold text	<ul style="list-style-type: none">▪ Keys that are pressed▪ Text typed into a GUI element, such as a box▪ GUI elements that are clicked or selected, such as menu and list items, buttons, tabs, and check boxes
<i>Italic text</i>	Text emphasis
Monospace text	<ul style="list-style-type: none">▪ File and directory names▪ System output▪ Code▪ Commands, their arguments, and argument values
<i>Monospace, italic text</i>	<ul style="list-style-type: none">▪ Code variables▪ Command variables
Monospace, bold text	Emphasized monospace text



Warning

Indicates that failure to follow directions could result in bodily harm or death.



Caution

Indicates that failure to follow directions could result in damage to equipment or data.



Important

Provides clarifying information or specific instructions.

Note: Provides additional information.

TECHNICAL SUPPORT

For worldwide technical support information, see <http://www.tandbergdata.com>.

Before contacting support, collect the following information:

- ▶ Product model names and numbers
- ▶ Technical support registration number (if applicable)
- ▶ Product serial numbers
- ▶ Error messages
- ▶ Operating system type and revision level
- ▶ Detailed questions

PRODUCT WARRANTIES

For information about product warranties, see <http://www.tandbergdata.com>.

1

BEFORE YOU START

In this chapter:

- ▶ “Supported models” on page 9
- ▶ “Which operating systems are supported?” on page 9
- ▶ “How do I connect the drive to my server?” on page 9
- ▶ “Why is the SCSI bus type important?” on page 10
- ▶ “Your LTO tape drive” on page 12
- ▶ “Power specifications” on page 12
- ▶ “Usage models” on page 12
- ▶ “Drivers” on page 14
- ▶ “Backup software” on page 15

SUPPORTED MODELS

This guide describes how to install and operate the following LTO tape drive models:

- ▶ LTO-4 internal and external tape drives
- ▶ LTO-3 internal and external tape drives
- ▶ LTO-2 internal and external tape drives

For a detailed product specification, please refer to <http://www.tandbergdata.com>.

WHICH OPERATING SYSTEMS ARE SUPPORTED?

LTO tape drives can be connected to servers running under Windows®, Linux and other major operating systems. Refer to <http://www.tandbergdata.com> for the most recent information about the operating system versions that are supported.

HOW DO I CONNECT THE DRIVE TO MY SERVER?

The following guidelines apply:

- ▶ You will need a properly installed and configured SCSI host bus adapter (HBA) or a built-in SCSI controller on your server and a suitably-rated SCSI cable. See also “[Why is the SCSI bus type important?](#)” on page 10.
- ▶ For optimum performance the drive should be the only device on the SCSI bus.
- ▶ Always terminate the SCSI bus. LTO internal tape drives require terminators; external drives are auto terminating, as long as they are on a dedicated SCSI bus or the last device on a chain.
- ▶ Do not attach the drive to the same SCSI bus as your disk drive or to a RAID controller (unless you are connecting to a server with a Smart Array 6i RAID controller).

Note: Always refer to <http://www.tandbergdata.com> to ensure that you are connecting to a supported HBA running the recommended firmware version.

Internal drives

The tape drive is installed into a spare drive bay in your server and is attached to the SCSI bus of the host server. Use an LVD-compatible ribbon cable to connect the tape drive to a spare 68-pin, high density (HD), wide SCSI connector on the host server. The cable must be terminated. Refer to <http://www.tandbergdata.com> for supported products.

You need one industry-standard, 5¼-inch, half-height bay in which to install the LTO tape drive. Different models of server require different mounting methods. Refer to your server documentation for detailed information.

External drives

A 68-pin, wide, VHD-to-HD SCSI cable is required to attach the tape drive to the host server. See also “[Installing an external tape drive](#)” on page 25.

Check the usage models in “[Usage models](#)” on page 12. This shows how the LTO tape drive can be used in different system architectures.

See also “[Installing an external tape drive](#)” on page 25.

WHY IS THE SCSI BUS TYPE IMPORTANT?

The SCSI bus type determines the speed at which data can be transferred between devices on the bus and the maximum length of cable that can be used. LTO-4 and LTO-3 drives support a burst transfer rate of 320 MB/sec. LTO-2 drives support a burst transfer rate of 160 MB/sec. To benefit from this level of performance, it is important to ensure that the drives are connected to a SCSI bus of a similar or higher specification. This means that you need:

- ▶ **An Ultra320 bus for LTO-4 and LTO-3 drives. An Ultra160 or Ultra320 SCSI bus for LTO-2 drives.** If you attach the drive to a lower specification SCSI bus, it may still work but data will not be transferred as quickly.
- ▶ **LVD-rated SCSI cabling and terminators.** The LVD interface enables the data to be transferred at the drive’s maximum rate.

Table 1-1 Supported SCSI bus types

SCSI Bus Type	Supported
Ultra320 LVD	<p>Yes. This is a recommended configuration for all LTO tape drives.</p> <p>Do not daisy chain LTO-4 or LTO-3 tape drives because performance may be degraded. Do not daisy chain LTO-2 tape drives with Ultra320 devices.</p>
Ultra160 LVD	<p>Yes. This is a recommended configuration for LTO-2 tape drives. It is an acceptable configuration for LTO-4 and LTO-3 tape drives.</p> <p>Up to two LTO-2 tape drives may be daisy-chained. Do not daisy-chain LTO-4 or LTO-3 tape drives.</p>
Ultra2 LVD	<p>Yes. This is acceptable for one LTO-2 drive per bus.</p> <p>Do not use with LTO-4 or LTO-3 tape drives and do not daisy-chain LTO-2 tape drives.</p>
Ultra wide LVD and single-ended	<p>These are not recommended configurations because they will restrict performance.</p>
Ultra narrow, single-ended	<p>No. This will severely restrict performance and you will need a suitable cable or adapter.</p>
High Voltage Differential	<p>No. The drive will not work and you may damage the drive or controller.</p>

YOUR LTO TAPE DRIVE

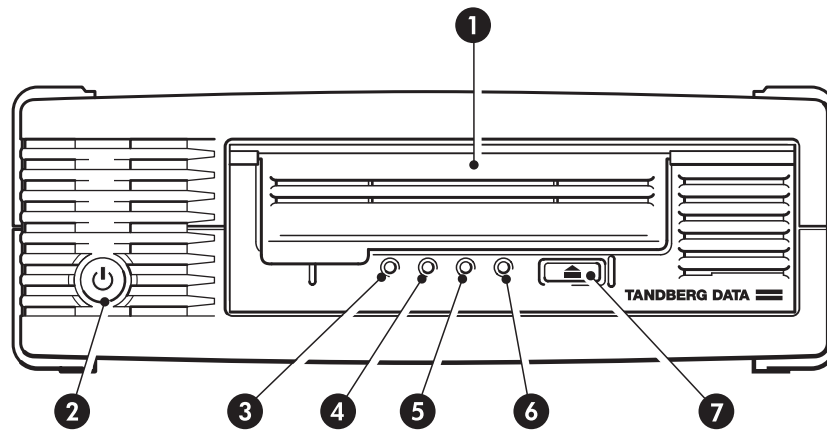

- | | |
|---|-----------------|
| 1. Cassette door | 5. Drive LED |
| 2. On/Off switch (external drives only) | 6. Ready LED |
| 3. Clean LED | 7. Eject button |
| 4. Tape LED | |

Figure 1-1 Front view of half-height LTO external tape drive

POWER SPECIFICATIONS



Caution

Never use a cable where power is supplied through the SAS connector because this may damage the drive. For internal drives, always use a spare power cable from the server's internal power supply to the conventional power connector on the drive itself.

For a detailed product specification, please refer to <http://www.tandbergdata.com>.

USAGE MODELS

LTO tape drives can be used in a standalone or network environment. However, they should always be directly attached to suitably-rated SCSI connector on the storage server.

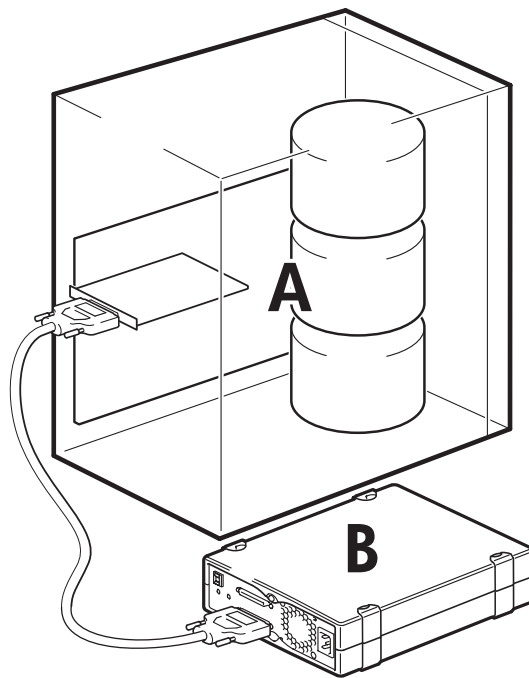

- A Server
- B Tape drive

Figure 1-2 Usage model

The following table shows the recommended usage models and “[Optimizing performance](#)” on page 44 provides further information about factors that can affect performance.

Table 1-2 Recommended usage models

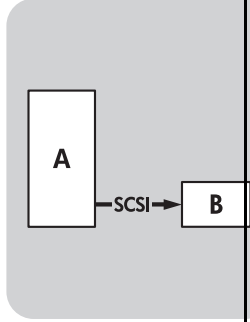
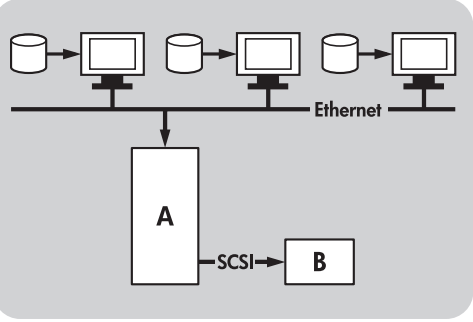
	Direct Attach, single storage server	Across the Network, single storage server, multiple clients
		
LTO-4	Recommended	Not recommended
LTO-3	Recommended	Not recommended
LTO-2	Recommended	Recommended, anything less than Gigabit Ethernet may limit performance

A RAID disk subsystem is recommended for all usage models.

A single spindle disk will not be able to deliver good data throughput for an LTO-4 or LTO-3 tape drive at any compression ratio. To maximize the capability of your LTO-4 or LTO-3 tape drive, utilize aggregated disk sources (RAID) with multiple disk spindles.

A single spindle disk, particularly a fast disk such as a 15K RPM drive, will be sufficient for LTO-2 tape drives, but be aware of other factors that can affect performance—such as, compressibility of data, disk fragmentation and the number of files. See also “[Optimizing performance](#)” on page 44.

Other usage models

The tape drive may work with other usage models, such as network attach storage (NAS) and storage area networks (SAN), but there is currently no technical support for installing and using standalone LTO tape drives with these architectures. Similarly, connection to fibre channel may be possible, if you purchase and install a fibre channel/SCSI bridge, but it is not currently a supported option. Please check <http://www.tandbergdata.com> for the latest supported configurations.

DRIVERS

The manufacturer’s Tape driver is suitable for use in most applications, but refer also to the documentation of your software application to ensure you are using the recommended driver.

On Windows systems, we strongly recommend that you use the installer package supplied by your manufacturer to install the drivers. Updates to the drivers may be provided from time to time on <http://www.tandbergdata.com>. We recommend that these are installed after using the installer package.

On Linux and UNIX operating systems, drivers are included with the operating system and should be loaded automatically. To upgrade drivers we recommend that you patch to the latest version of the operating system.

BACKUP SOFTWARE

For optimum performance it is important to use a backup application that is appropriate for your system's configuration. In a direct attach configuration, where the tape drive is attached to a standalone server, you can use backup software that is designed for a single server environment. In network configurations you will need backup software that supports enterprise environments.

Further details about suitable products can be found on <http://www.tandbergdata.com>. It is important to check for software compatibility and install any recommended upgrades.

Note: Certain backup applications require you to use their own Tape driver instead of the manufacturer's Tape driver.

Enabling encryption (LTO-4 only)

Your LTO-4 tape drive includes hardware capable of performing data encryption while writing and data decryption while reading, both at full speed. This is only possible with Ultrium 1.6 TB media. See also "[LTO-4 tape drives and encryption](#)" on page 38.

If you wish to make use of the encryption capability, you must enable this feature via the backup software application. Refer to your supplier to find out which applications support this advanced data protection capability.

NOTES

2

INSTALLING AN INTERNAL LTO TAPE DRIVE

If you are installing an external LTO tape drive, please refer to “[Installing an external tape drive](#)” on page 25.

Note: Always refer to <http://www.tandbergdata.com> to find out which HBAs and cables are appropriate for your combination of server and tape drive.

In this chapter:

- ▶ “[Check the internal drive's SCSI ID](#)” on page 17
- ▶ “[Prepare mounting bay](#)” on page 18
- ▶ “[Attach mounting hardware](#)” on page 19
- ▶ “[Install drive](#)” on page 20
- ▶ “[Attach power and SCSI cables](#)” on page 21
- ▶ “[Secure the drive](#)” on page 23
- ▶ “[Reboot the server](#)” on page 24

CHECK THE INTERNAL DRIVE’S SCSI ID

Your LTO tape drive is shipped with a default SCSI ID of 2. Each device on the SCSI bus must have a unique SCSI ID number. The drive can be assigned any *unused* ID between 0 and 15. Do not use SCSI ID 7, which is reserved for the SCSI controller. SCSI ID 0 is typically assigned to the boot disk and should also not be used unless the tape drive is on a dedicated SCSI bus.



Caution

Static electricity can damage electronic components. Always wear an antistatic wriststrap if possible. If not, to equalize the electromagnetic charges, touch a bare metal part of the server (such as the back plate) before you remove the tape drive from its bag.

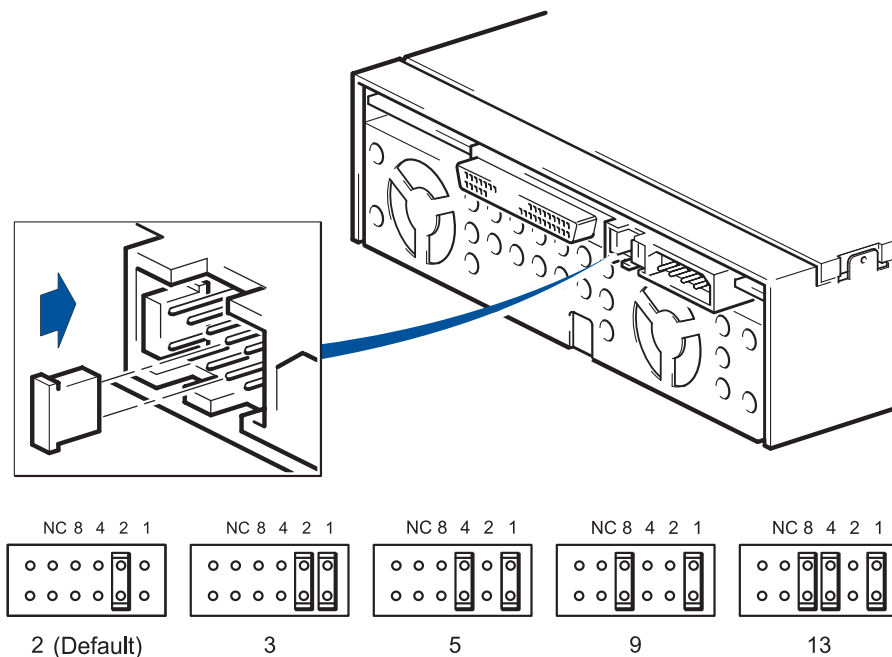

Figure 2-1 Checking the SCSI ID

1. Determine whether you need to change the SCSI ID from the default of 2.
2. Change the tape drive's SCSI ID, if necessary.

The SCSI ID is set using jumpers on a set of pins at the rear of the drive, as shown in [Figure 2-1](#). Use tweezers or small pliers to move the jumpers to the pattern corresponding to the ID you want. Spare jumpers are provided with the drive.

PREPARE MOUNTING BAY

You need one industry-standard, 5¼-inch, half-height bay in which to install the LTO tape drive.



Warning To avoid personal injury or damage to the server or tape drive, ensure that the server is disconnected from the mains power supply while you install the drive.



Caution Static electricity can damage electronic components. Always wear an antistatic wriststrap if one is available. If not, after you have disconnected power from the server and removed the cover, touch a bare metal part of the chassis. Similarly, touch a bare metal part of the drive before installing it.

1. Assemble the necessary tools and materials:
 - ▶ Phillips screwdriver
 - ▶ Flat-bladed screwdriver (if your server uses slotted screws)
 - ▶ Torx screwdriver (if your server uses torx screws)
 - ▶ Your server manuals (for reference during installation)

2. Perform a normal system shutdown and turn off the server and any connected peripherals.
3. Remove the cover and front panel from the server, as detailed in your server's documentation.

As you work inside the server, you may have to disconnect other signal cables or power cables from other devices to maneuver the new drive into place. If you have to do this, make a note of their position and connections so you can put them back correctly later.

Note: The server must provide forced cooling and be capable of drawing 6 cfm (0.17 m³/minute or 10.08 m³/hour) of air through the tape drive at up to 40° C ambient operation. This reduces to 4 cfm at 35° C ambient operation. Ensure that empty bays have the appropriate blanking plates installed so that airflow is maintained.

4. Remove the filler panel from a spare 5¼-inch bay of your server, as described in your server's documentation. With some servers, you must also remove the half-height device divider.
5. You are now ready to install your tape drive.

ATTACH MOUNTING HARDWARE

If your server requires special rails or other hardware to install the tape drive, mount them on the tape drive now.

If your server does not require special mounting hardware, proceed to "Install drive" on page 20 now.

Please check your server documentation to ascertain the correct method of mounting, and to check whether mounting hardware is provided with the server or must be purchased separately.



Caution

The LTO half-height drive only allows 3 mm of the engagement of the screw into the drive. If you remove an existing drive, do not assume the screws that you remove are the correct length for your new LTO drive. Always use 3 mm screws and use washers or shims to tighten, if necessary.

Different models of server require different mounting methods. Always refer to your server documentation for details. The following diagrams illustrate common mounting methods. If mounting hardware is supplied with your tape drive, it may not be exactly the same as shown in the illustrations.

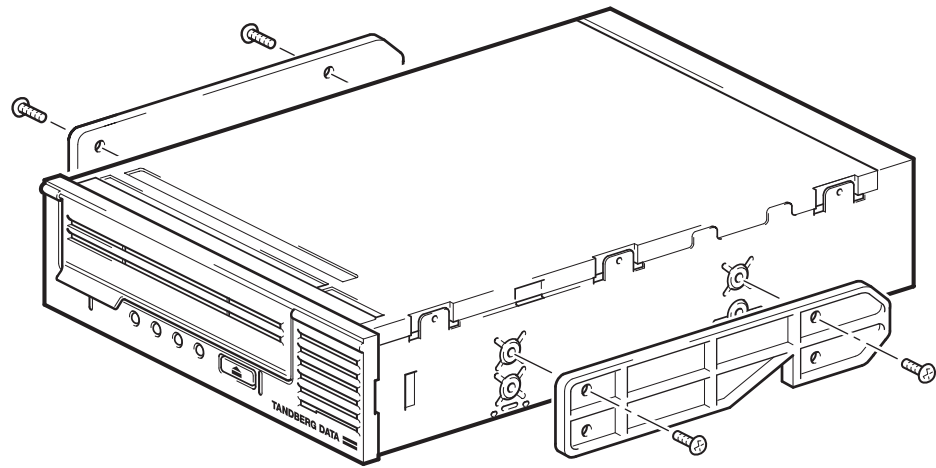
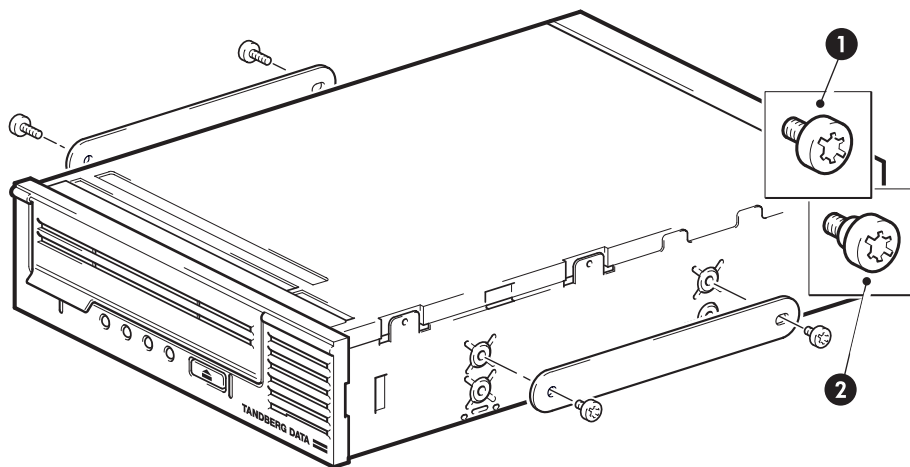

Figure 2-2 Attaching mounting rails



1. M3 mounting screws
2. M3 offset mounting screws

Figure 2-3 Attaching locating screws

INSTALL DRIVE

Note: If cable access for the tape drive bay is awkward, it may be easier to access power and other connections if the tape drive is installed in the top bay. You may need to move other devices to lower bays to achieve this. Refer also to your server documentation.

Slide the tape drive into the open bay, aligning the tray or rails with the slots in the bay, as shown in [Figure 2-4](#) on page 21.

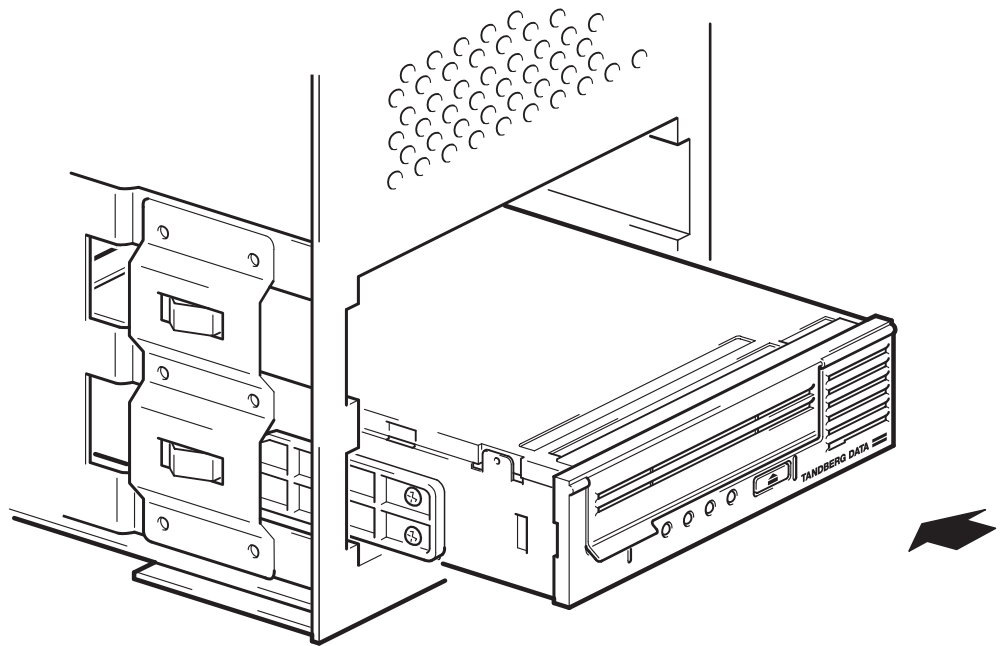

Figure 2-4 Installing tape drive

Note: The illustration shows a server that uses mounting rails. If your server does not use mounting hardware, check that the holes in the chassis are aligned with the holes in the side of the tape drive.

Do not secure the drive at this point because you may have to move the drive to get the cables into place.

ATTACH POWER AND SCSI CABLES

To support the high performance of the tape drive it is important that you connect to a recommended SCSI bus and use a suitably-rated SCSI cable, see [Why is the SCSI bus type important?](#).

1. Check your server or HBA documentation to ensure that the SCSI bus and cabling supports the tape drive's bus speeds: Ultra320 for LTO-4 and LTO-3 tape drives, Ultra160 for LTO-2 tape drives.
2. Attach the SCSI ribbon cable supplied with the tape drive to the SCSI host bus adapter and connect it to the SCSI connector of the drive, as shown in [Figure 2-5](#).
3. Attach a spare power cable from the server's internal power supply to the power connector, as shown in [Figure 2-5](#).
4. Attach a spare connector on the server's built-in SCSI bus or HBA's SCSI ribbon cable to the SCSI connector of the drive, as shown in [Figure 2-5](#).

5. If the drive is the last device on the SCSI chain, make sure that the SCSI cable is terminated correctly.

Daisy-chaining two devices is not recommended. If you do so, do not mix drive families (only daisy-chain with other LTO tape drives) and do not daisy chain any Ultra320 devices. See also Table 2, “Supported SCSI bus types.”

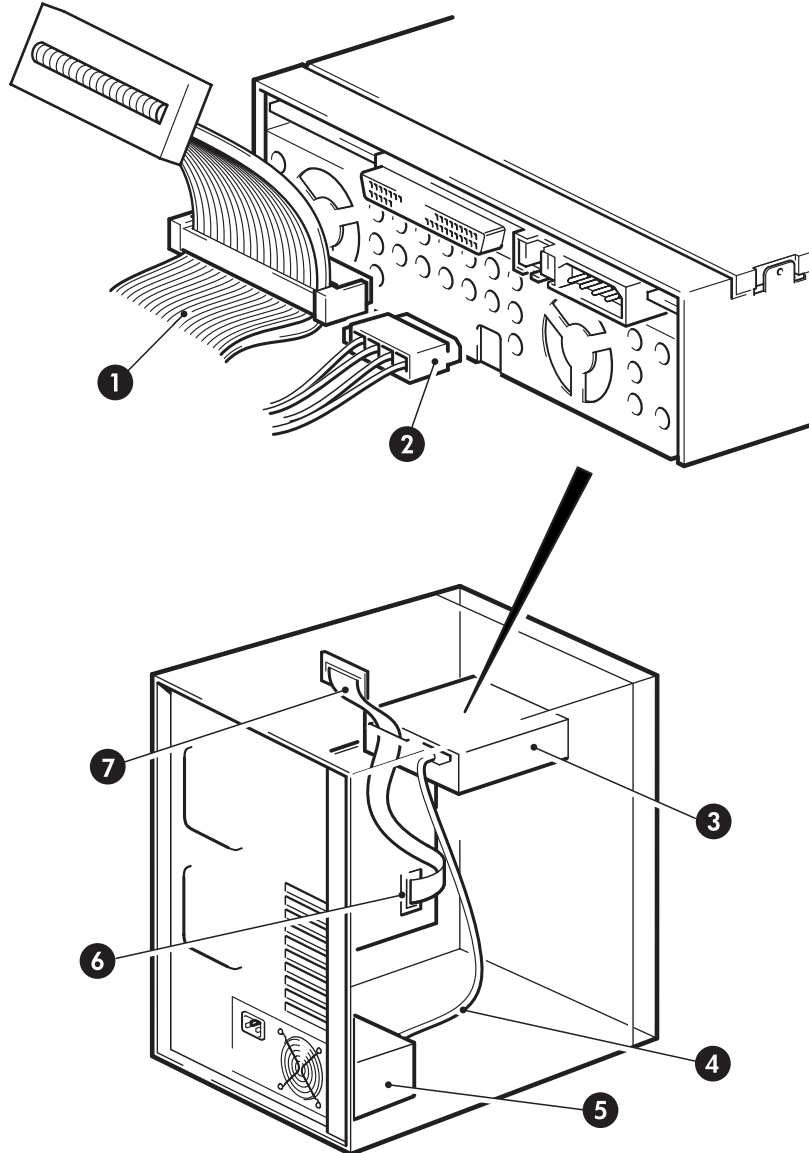

- 1 and 7 terminated SCSI cable
- 2 and 4 power cable
- 3 tape drive
- 5 server's power supply
- 6 SCSI controller

Figure 2-5 Connecting power and SCSI cables

Where should the SCSI terminator be?

Termination must be present at two and **ONLY** two positions on the SCSI bus—at the beginning of the SCSI bus and at the end of the SCSI bus.

Termination is normally enabled by default on the HBA and most internal SCSI cables have a terminator attached. This will usually be a small, rectangular block of plastic attached to the cable end and marked 'SCSI Terminator'.

Therefore, assuming the HBA is the first device on the bus, you should check that the second terminator is placed after the last device, as shown in [Figure 2-5](#), item 1.

SECURE THE DRIVE

1. Secure the drive, as described in your server documentation. The following diagrams are examples only.

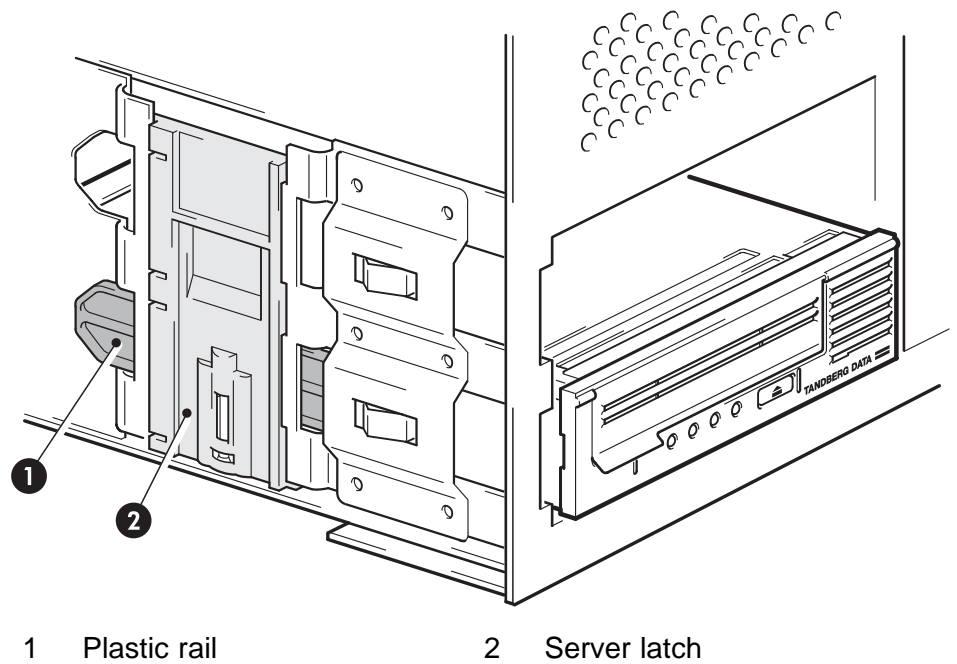
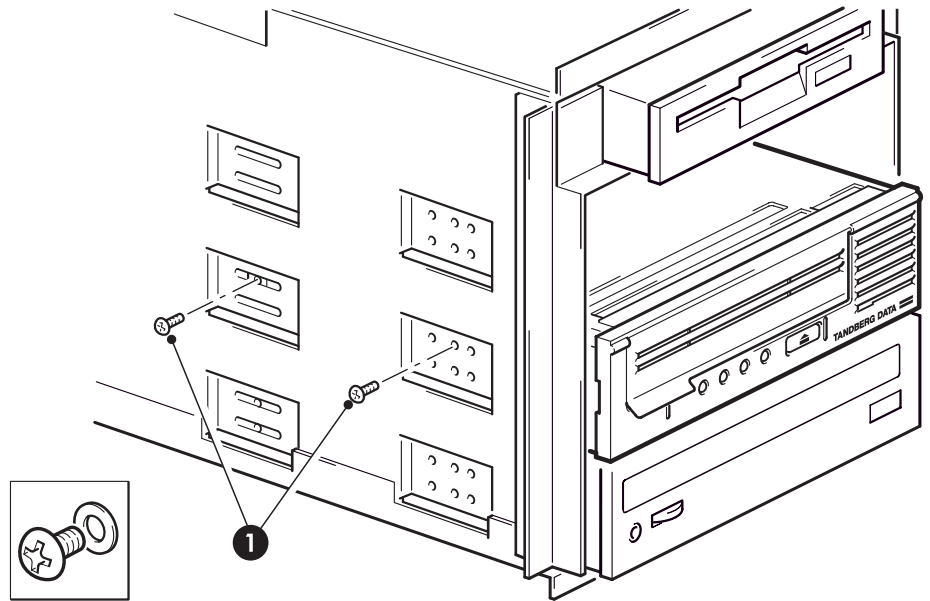

Figure 2-6 Securing drive, mounting hardware used



- 1 M3 screws

Figure 2-7 Securing drive, no mounting hardware used

Note: Use 3 mm screws and, if you cannot tighten the screws, use washers to secure them.

2. Ensure blanking plates are in place over empty bays and replace the cover on the server.

REBOOT THE SERVER

Reboot the server to power up the tape drive and server.

Watch the boot screen carefully after installation. If there are any error or unexpected messages go back and check the SAS cabling carefully.

- ▶ Have you reconnected all devices securely?

If this does not resolve the problem, refer to “[Troubleshooting](#)” on page 43 for further guidelines.

3

INSTALLING AN EXTERNAL LTO TAPE DRIVE

If you are installing an internal LTO tape drive, please refer to [“Installing an internal tape drive”](#) on page 17.

In this chapter:

- ▶ [“Check the external drive's SCSI ID”](#) on page 25
- ▶ [“Connect the SCSI cable”](#) on page 26
- ▶ [“Connect the power cable”](#) on page 28
- ▶ [“Reboot the server”](#) on page 28

CHECK THE EXTERNAL DRIVE'S SCSI ID

Your LTO tape drive is shipped with a default SCSI ID of 2. Each device on the SCSI bus must have a unique SCSI ID number. The drive can be assigned any *unused* ID between 0 and 15. Do not use SCSI ID 7, which is reserved for the SCSI controller. SCSI ID 0 is typically assigned to the boot disk and should also not be used unless the tape drive is on a dedicated SCSI bus.

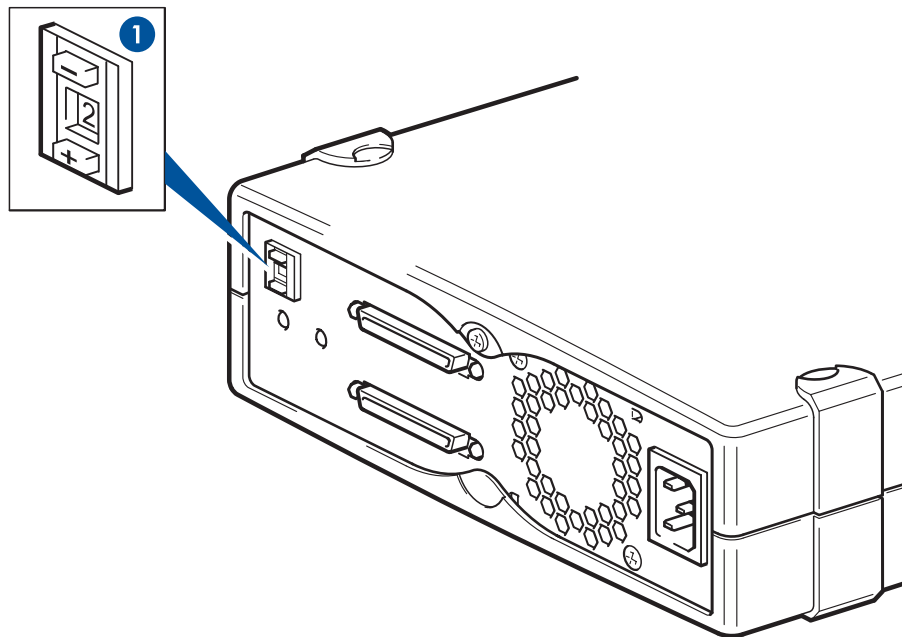

1. SCSI ID switch

Figure 3-1 Setting the SCSI ID

1. Determine whether you need to change the SCSI ID from the default of 2.
2. Change the tape drive's SCSI ID, if necessary.

Use a small screwdriver or a ball-point pen to press the indented SCSI ID selector buttons on the rear panel (see [Figure 3-2](#)) until the required value is displayed. Do not use a pencil because small bits of graphite could contaminate the drive.

Note: The server and the tape drive SCSI IDs are only checked at power-on. To change the SCSI ID after installation, power down both the server and the tape drive, change the drive's SCSI ID, power up the tape drive, and then power up the server.

CONNECT THE SCSI CABLE

A 68-pin, wide VHD-to-HD SCSI cable is required to connect your LTO tape drive to a VHD SCSI port on an LVD SCSI bus. If your server has an HD SCSI port, you must either purchase and install a VHD-to-HD adapter or use an HD-to-HD cable instead of the supplied cable. Refer to <http://www.tandbergdata.com> for recommended products.



Caution To avoid damaging the computer or tape drive, ensure that both are powered off while you attach the SCSI cable.

1. Make sure you are connecting to a recommended SCSI bus type. For optimum performance your tape drive should only be connected to a SCSI bus that can transfer data at a rate that supports the tape drive's maximum burst transfer speed. LTO-3 tape drives should be connected to an Ultra320 SCSI bus, LTO-2 tape drives may be connected to an Ultra160 SCSI bus. See also "Why is the SCSI bus type important?" on page 10. Do **not** connect the tape drive to a single-ended SCSI bus or to a RAID controller. For optimum performance, we recommend that your LTO tape drive is installed on a dedicated SCSI bus. If it is not, do not connect it to the same bus as your disk drive.
2. Perform a normal system shutdown and turn off the server and any connected peripherals.
3. Attach the VHD connection on the SCSI cable to the server's external SCSI connector and secure it by tightening the screws.

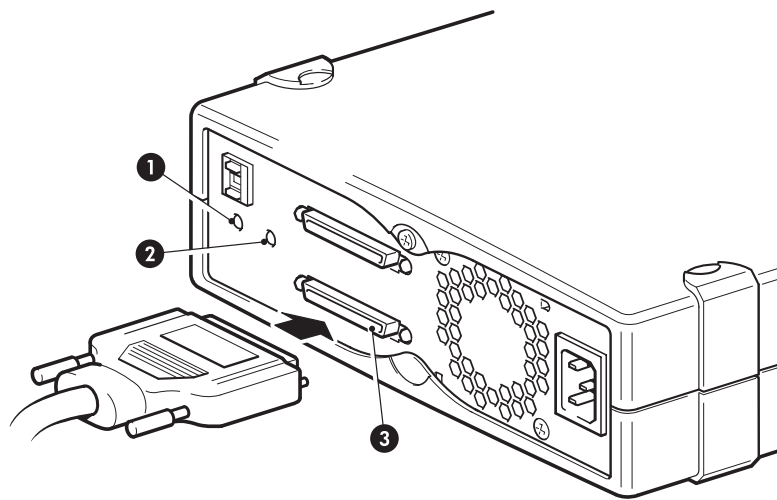

- 1 Act TERM LED
- 2 Fan/Power LED

Figure 3-2 Connecting the SCSI cable

4. Attach the HD connection on the SCSI cable to the SCSI-IN connector on the rear panel of the tape drive and secure it by tightening the screws. (See Figure 3-2.) Do **not** connect the cable to the SCSI-OUT connector.
5. The SCSI-OUT connector is only used when daisy-chaining two devices. This is not recommended. If you do so, do not mix drive families (only daisy-chain with other LTO tape drives) and do not daisy chain Ultra320 tape drives.

Does the tape drive need a terminator?

If the tape drive is on a dedicated SCSI bus, it does not require a terminator. When the cable is connected to the SCSI-IN connector, the enclosure provides active termination.

If it is not the only device on the SCSI bus, you must make sure that the SCSI bus is terminated. You can do this in two ways:

- ▶ Place the tape drive at the end of the chain and attach the HD connection on the SCSI cable to the SCSI-IN connector; the enclosure provides active termination.

- ▶ Attach the HD connection on the SCSI cable to the SCSI-IN connector and use the SCSI-OUT connector on the tape drive to connect to the next device in the chain. Make sure that the last device in the chain is terminated with an LVD multimode terminator

CONNECT THE POWER CABLE

1. Plug the power cable securely into the socket on the rear panel of the drive.
2. Plug the other end of the power cable into the power outlet. The power on/off switch is on the front panel, see [Figure 3-3](#).

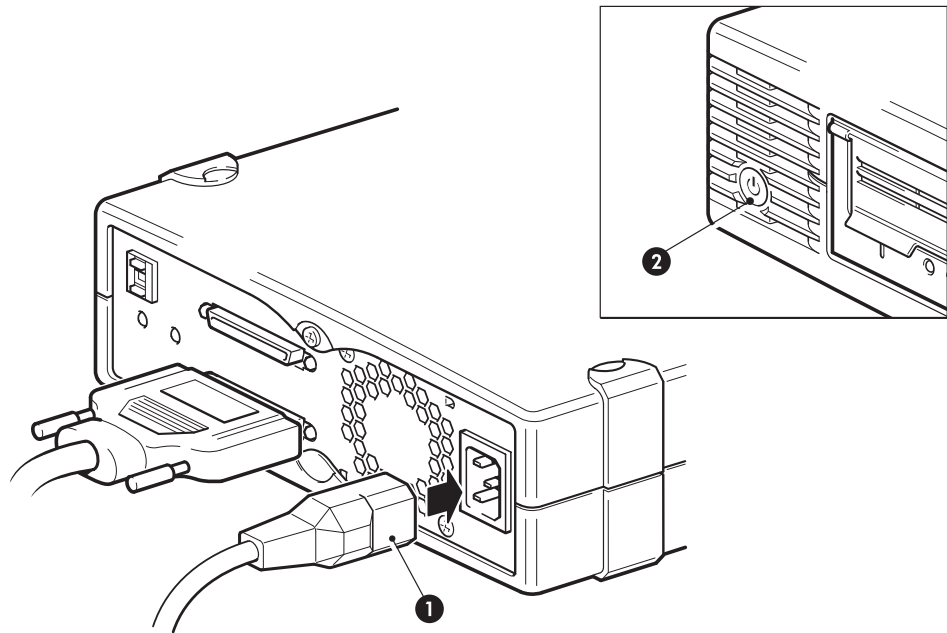

- 1 Power cable
- 2 Power on/off switch

Figure 3-3 Connecting the power cable

REBOOT THE SERVER

Switch on the tape drive and power up the server. The power on/off switch is on the front panel.

Watch the boot screen carefully after installation. If there are any error or unexpected messages go back and check the cabling carefully.

If this does not resolve the problem, refer to “[Troubleshooting](#)” on page 43 for further guidelines.

4

VERIFY INSTALLATION

Once you have installed the drive hardware, check that drivers have been installed correctly and you have the correct version of backup software, and verify that the tape drive is functioning properly before you store your valuable data.

1. Switch on the drive and the server.
2. The tape drive will run its hardware self-test, which takes about 5 seconds. If self-test passes, the green Ready LED flashes and then shows steady green. If the test fails, the Drive Error and Tape Error LEDs flash, while the Ready and Clean LEDs are off. This continues until the drive is reset. See “[understanding LEDs](#)” on page 31 for more information about front panel lights.
 - ▶ **Installing drivers (Windows)**
We recommend that you download the latest driver from <http://www.tandbergdata.com> before installation. When the Windows Found New Hardware wizard runs, follow the on-screen instructions to install drivers from the download location.
 - ▶ **Installing drivers (other operating systems)**
Drivers are included with the operating system and should be loaded automatically. To upgrade drivers we recommend that you patch to the latest version of the operating system.
Note: Certain backup applications require you to use their own Tape driver instead of the manufacturer’s Tape driver.
3. Verify that the tape drive installation was successful.
4. For all operating systems ensure that you have downloaded any upgrades necessary for your backup application. Check <http://www.tandbergdata.com> for software compatibility and install any recommended upgrades.
5. Carry out a backup and restore test to check that the drive can write data to tape. Use a blank cartridge.

Native backup applications can be used to check basic tape drive operation, but they will not support all the advanced features of your tape drive. We recommend that you upgrade your software application before running this test.

NOTES

5

UNDERSTANDING THE LEDs

In this chapter:

- ▶ “Front view of LTO tape drive with LEDs” on page 31
- ▶ “Understanding LED sequences” on page 31

FRONT VIEW OF LTO TAPE DRIVE WITH LEDs

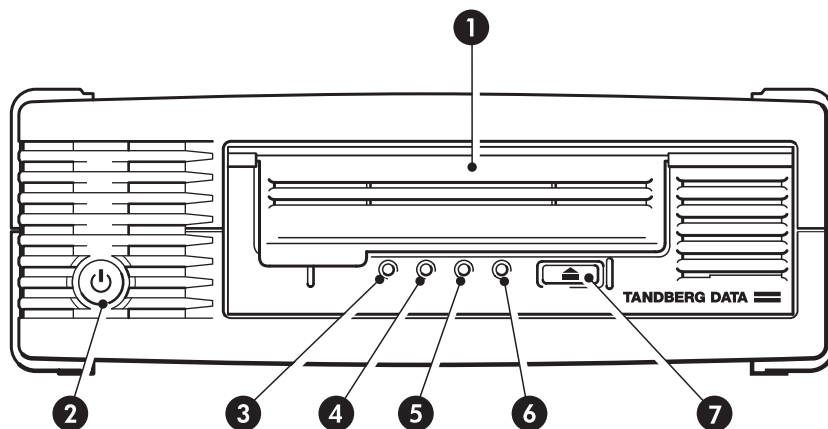

- | | |
|---|-----------------|
| 1. Cassette door | 5. Drive LED |
| 2. On/Off switch (external drives only) | 6. Ready LED |
| 3. Clean LED | 7. Eject button |
| 4. Tape LED | |

Figure 5-1 Front view of external tape drive

UNDERSTANDING LED SEQUENCES

The meaning of different patterns of LEDs is as follows:

Table 5-1 LED sequences

LED Sequence	Cause	Action required
<i>All LEDs OFF.</i>	Drive may not have power, may be faulty or may have been power cycled or reset during a firmware upgrade.	<p>Make sure the drive is switched on. The power on/off switch on an external drive incorporates a green LED.</p> <p>Check the power cable connection and replace the cable if necessary. On external drives, you can use the power cable from your monitor or another device to check that the connection is working.</p> <p>If the power supply is present and all LEDs remain off, power cycle or reset the drive. If it still fails, call for service.</p>
<i>Ready and Clean OFF. Drive and Tape FLASH.</i>	The drive has failed to execute power-on self test (POST).	<p>Power cycle or reset the drive.</p> <p>If the error condition reappears, call for service.</p>
<i>Ready is ON.</i>	The drive is ready for operation.	None. This is normal.
<i>Ready FLASHES.</i>	The drive is carrying out a normal activity (read, write).	<p>None.</p> <p>If the drive is upgrading firmware, do not reset or power cycle it.</p>
<i>Ready FLASHES fast.</i>	The drive is downloading firmware.	<p>None.</p> <p>Do not reset or power cycle the drive.</p>
<i>Ready is OFF, others are ON.</i>	Firmware is being reprogrammed.	<p>None.</p> <p>Do not reset or power cycle the drive.</p>
<i>Clean FLASHES.</i>	The drive requires cleaning.	<p>Load the LTO cleaning cartridge. See “Cleaning cartridges” on page 37 for supported cartridges and instructions.</p> <p>If the Clean LED is still flashing when you load a new or known good data cartridge after cleaning, call for service.</p>

LED Sequence	Cause	Action required
<i>Ready FLASHES and Clean is ON.</i>	Cleaning is in progress.	None. The cleaning cartridge will eject on completion. The cleaning cycle can take up to 5 minutes to complete.
<i>Tape FLASHES.</i>	The drive believes the current tape or the tape just ejected is faulty.	Unload the tape cartridge. Make sure that you are using the correct format cartridge; an LTO data cartridge or LTO Universal Cleaning Cartridge. (See “ Use the correct media ” on page 37.) Reload the cartridge. If the Tape LED still flashes or starts flashing during the next backup, load a new or known good cartridge. If the Tape LED is now off, discard the 'suspect' tape cartridge. If it is still on, call for service.
<i>The tape is ejected immediately and Tape FLASHES, or Drive FLASHES on unloading tape.</i>	The tape cartridge memory (CM) may be faulty.	Write-protect the cartridge by sliding the switch on the tape cartridge, see “ Write protecting cartridges ” on page 40. The tape can be loaded and the data read. Once the data is recovered, the cartridge must be discarded.
<i>Drive FLASHES.</i>	The drive mechanism has detected an error.	Load a new cartridge. If the error persists, power cycle or reset the drive. If the Drive LED remains on, call for service.
<i>Drive, Tape and Ready FLASH.</i>	There is a firmware download problem.	Insert a cartridge to clear the LED sequence. If the condition persists, call for service.
 <p><i>Drive and Ready ON with Tape and Clean OFF. Alternates repeatedly.</i></p>	The drive has a firmware error.	Power cycle or reset the drive. Upgrade the firmware. If the condition persists, call for service.

Table 5-2 Rear panel LED sequences (external tape drives only)

LED Sequence	Cause	Action required
<i>The Act TERM LED is OFF.</i>	The enclosure is not providing auto-termination.	Check that the drive's SCSI cable is connected to the SCSI-IN connector. Check whether a terminator or other SCSI cable is plugged into the SCSI-OUT connector. If a terminator is connected, remove it. If another SCSI cable is connected, make sure that the SCSI chain is terminated at the last device.
<i>The Fan/PWR LED is amber.</i>	There has been an enclosure failure or the cooling fan is not working correctly.	Call for service.
<p>Note: For the location of rear panel LEDs, see Figure 3-2 on page 27.</p>		

6

OPERATING YOUR TAPE DRIVE

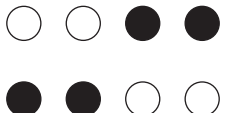
In this chapter:

- ▶ “Loading a cartridge” on page 35
- ▶ “Unloading a cartridge” on page 36
- ▶ “Removing power from the drive” on page 36

LOADING A CARTRIDGE

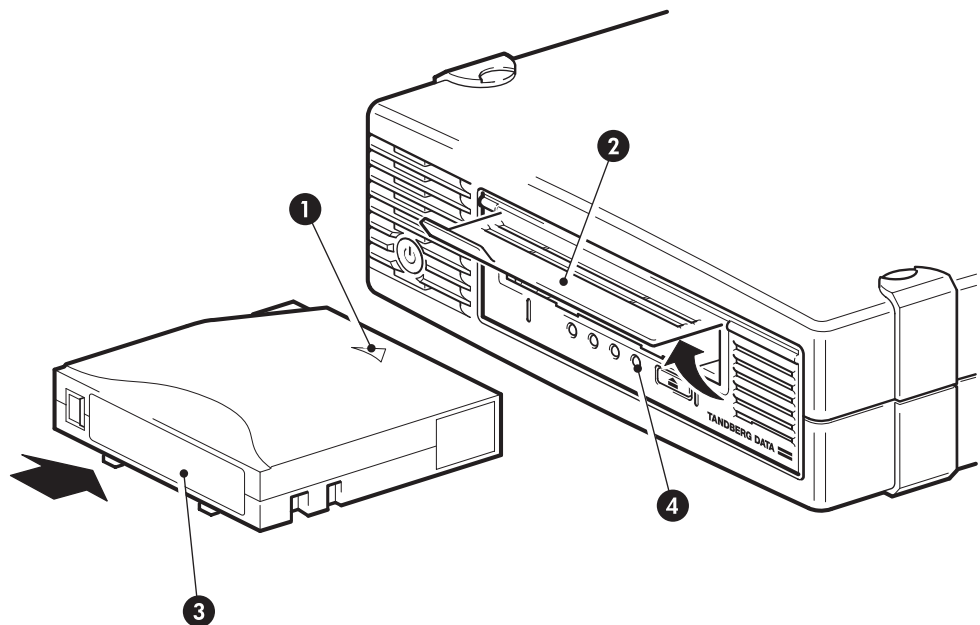

1. Arrow indicates leading direction
2. Cartridge door
3. Label area
4. Ready LED

Figure 6-1 Inserting a cartridge

1. Lift the cartridge door and insert the cartridge into the slot in the front of the drive with the white arrow uppermost and facing the drive door.
2. Apply gentle pressure until the drive takes the cartridge and loads it.

3. The Ready light flashes green while the drive performs its load sequence. When the cartridge is loaded, the Ready light shows steady green.

UNLOADING A CARTRIDGE



Caution Never try to remove a cartridge before it is fully ejected.

1. Press the Eject button on the front panel.

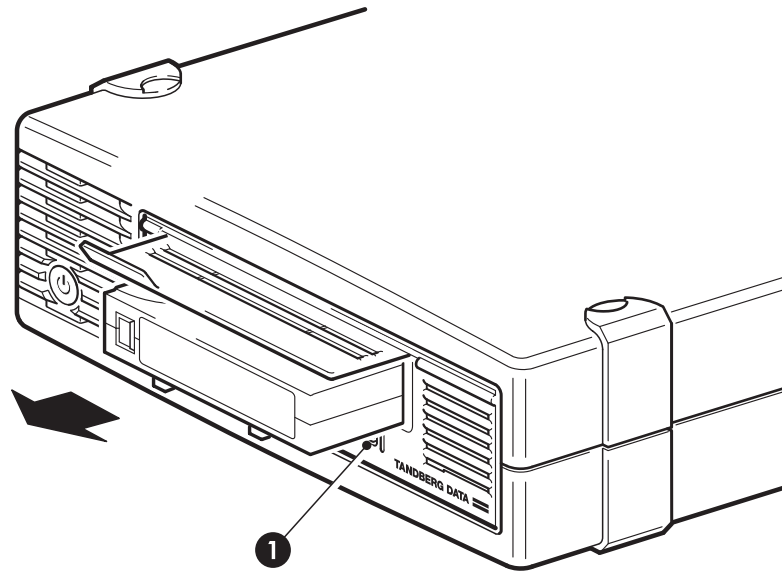

1. Eject button

Figure 6-2 Ejecting a cartridge

2. The drive will complete its current task, rewind the tape to the beginning, and eject the cartridge. The rewind process may take up to 10 minutes. The Ready light will flash to indicate that the unload is still in progress.

REMOVING POWER FROM THE DRIVE

To ensure reliable operation, do not remove power from the drive during read, write, fast-search, load and unload activities. Do not remove power during a firmware upgrade.

7

USE THE CORRECT MEDIA

For best performance we recommend branded media. See <http://www.tandbergdata.com> for recommended products.

In this chapter:

- ▶ “Cartridges” on page 37
- ▶ “WORM data cartridges” on page 38
- ▶ “LTO-4 tape drives and encryption” on page 38
- ▶ “Write protecting cartridges” on page 40
- ▶ “Cleaning the tape drive” on page 41
- ▶ “Handling cartridges” on page 41
- ▶ “Operating and storage environment” on page 42

CARTRIDGES

Cleaning cartridges

The recommended cleaning cartridges is the Ultrium Universal Cleaning Cartridge. This cleaning cartridge is designed to work with any LTO drive. It may be used for up to 50 cleans.

Data cartridges

LTO tape drives use Ultrium tape cartridges. These are single-reel cartridges that match your drive’s format and are optimized for high capacity, throughput and reliability. Compatible media can be recognized by the LTO logo, which is the same as the logo on the front of your drive. Do not use other format cartridges in your tape drive and do not use Ultrium cartridges in other format tape drives.

For optimum performance always use a data cartridge that matches the specification of your tape drive, (see [Table 7-1](#) on page 38). A lower specification will have a lower transfer speed and may not support write activities; a higher specification will not support read or write. We recommend:

- ▶ We recommend Ultrium 1.6 TB* RW and LTO 1.6 TB* WORM tape cartridges for use with LTO–4 tape drives.

- ▶ We recommend Ultrium 800 GB* RW and LTO Ultrium GB* WORM tape cartridges for use with LTO–3 tape drives.
- ▶ We recommend Ultrium 400 GB* RW tape cartridges for use with LTO-2 tape drives.

Table 7-1 Data cartridge compatibility

Tape drive model	Ultrium 200 GB* data cartridge	Ultrium 400 GB* data cartridge	Ultrium 800 GB* data cartridge	Ultrium 1.6 TB* data cartridges
LTO-4	not supported	read/write	read/write write once/ read many	read/write write once/ read many
LTO-3	read only	read/write	read/write write once/ read many	not supported
LTO-2	read/write	read/write	not supported	not supported
* Capacity assumes 2:1 compression.				

WORM DATA CARTRIDGES

LTO–4 and LTO–3 tape drives include support for both re-writable and Write-Once, Read-Many, WORM, data cartridges. WORM cartridges provide for an enhanced level of data security against accidental or malicious alteration of data on the tape cartridge. The WORM data cartridge can be appended to maximize the full capacity of the tape cartridge, but the user will be unable to erase or overwrite data on the cartridge. Any attempt to modify a WORM cartridge to enable writing over existing data will result in the media becoming permanently write protected. It should still be readable in a WORM drive, depending upon the severity of the tampering, but no further appended backups will be possible.

WORM data cartridges are clearly identified by their distinctive, two-tone cartridge color. They can only be used with LTO tape drives that support the WORM feature.

To check whether your backup or archive software application supports WORM cartridges, refer to <http://www.tandbergdata.com>.

LTO–4 TAPE DRIVES AND ENCRYPTION

Your LTO–4 tape drive includes hardware capable of performing data encryption at full speed while writing data, and decrypting when reading.

Encryption is the process of changing data into a form that cannot be read until it is deciphered, protecting the data from unauthorized access and use. LTO–4 tape drives use the strongest version of the industry-standard AES encrypting algorithm to protect your data.

To make use of this feature you need:

- ▶ A backup application that supports hardware encryption
- ▶ Ultrium 1.6 TB R/W or WORM media; no encryption will be performed when writing earlier generations of tape

When should I use encryption?

Your company policy will determine when you need to use encryption. For example, it may be mandatory for company confidential and financial data, but not for personal data. Company policy will also define how encryption keys should be generated and managed. Backup applications that support encryption will generate a key for you or allow you to enter a key manually.

Note: Encryption with keys that are generated directly from passwords or passphrases may be less secure than encryption using truly random keys. Your application should explain the options and methods that are available. Please refer to your application's user documentation for more information.

How do I enable encryption?

Hardware encryption is turned off by default and is switched on by settings in your backup application, where you also generate and supply the encryption key. Your backup application must support hardware encryption for this feature to work. The software supplied with the tape drive provides this support. See <http://www.tandbergdata.com> for an up-to-date list of other suitable backup software.

When will I be asked to enter the key?

Encryption is primarily designed to protect the media once it is offline and to prevent it being accessed from another machine. You will be able to read and append the encrypted media without being prompted for a key as long as it is being accessed by the machine and application that first encrypted it.

There are two main instances when you will need to know the key:

- ▶ If you try to import the media to another machine or another instance of the backup application
- ▶ If you are recovering your system after a disaster

What happens if I don't remember the key?

If you are unable to supply the key when requested to do so, neither you nor Technical Support will be able to access the encrypted data.

This guarantees the security of your data, but also means that you must be careful in the management of the encryption key used to generate the tape.



Warning You should keep a record or backup of your encryption keys and store them in a secure place separate from the computer running the backup software.

Does encryption affect tape drive performance?

Hardware encryption can be used with or without compression and without speed or capacity penalties.

Does the tape drive encrypt media in an earlier Ultrium format?

No. Encryption is supported only on Ultrium 1.6 TB media (R/W andr WORM).

Ultrium 1.6 TB tapes encrypted on LTO–4 tape drives can be read on any compatible LTO–4 tape drive that supports hardware encryption.

LTO–4 tape drives can read Ultrium 800 GB and Ultrium 400 GB media and write Ultrium 800 GB media, but hardware encryption is not supported on these formats.

Where can I get more information?

For detailed instructions about enabling encryption please refer to the documentation supplied with your backup application. This will also highlight any default states, for example when copying tapes, that may need changing if using encrypted tapes.

WRITE PROTECTING CARTRIDGES

Warning Always remove the cartridge from the tape drive before you change the write protection.

If you want to protect the data on a cartridge from being altered or overwritten, you can write protect the cartridge.

- ▶ To write protect a cartridge, push the switch to the right to prevent any data recording on the cartridge. Note the padlock on the tab that indicates that the cartridge is protected.
- ▶ To write enable a cartridge, push the switch to the left to allow data recording on the cartridge. [Figure 7-1](#) on page 41 illustrates the location of the write-protect tab.

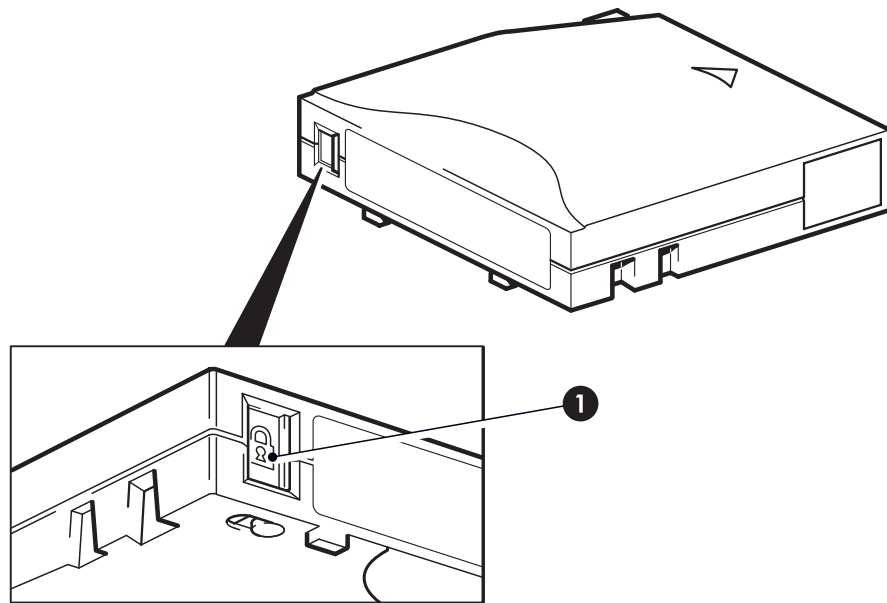

1. Write-protect tab

Figure 7-1 Write protecting a cartridge

Write-protection will not protect your cartridges against magnets. Write-protection will not prevent a cartridge being erased by bulk-erasure or degaussing. Do **not** bulk erase LTO format cartridges. This will destroy pre-recorded servo information and make the cartridge unusable.

CLEANING THE TAPE DRIVE

You must use the Ultrium Universal Cleaning Cartridge with LTO tape drives, as other cleaning cartridges will not load and run.

To clean the tape drive:

LTO tape drives do not require regular cleaning. An Ultrium Universal Cleaning Cartridge should only be used when the orange Clean LED is flashing.

1. Insert the Ultrium Universal Cleaning Cartridge.
2. The drive will carry out its cleaning cycle and eject the cartridge on completion (which can take up to 5 minutes). During the cleaning cycle the orange Clean LED will be on solidly and the green Ready LED will flash.

Each Ultrium Universal Cleaning Cartridge cleaning cartridge can be used up to 50 times with LTO tape drives. If the cleaning cartridge is ejected immediately with the Tape LED on, it has expired.

HANDLING CARTRIDGES

- ▶ Do not attempt to clean the tape path or tape guides inside the cartridge.
- ▶ Do not leave cartridges in the drive. The tape loses tension in the power-off state, which can lead to problems, particularly if the drive has been moved.
- ▶ Do not leave cartridges in excessively dry or humid conditions.

- ▶ Do not leave cartridges in direct sunlight or in places where magnetic fields are present (for example, under telephones, next to monitors or near transformers).
- ▶ Do not drop cartridges or handle them roughly.
- ▶ Stick labels onto the label area only.
- ▶ Do not bulk erase (or degauss) LTO format cartridges because this will render them unusable.

OPERATING AND STORAGE ENVIRONMENT

To prevent condensation and for long life, the cartridge should only be operated or stored as follows:

- ▶ Operation: 100° C to 45° C (50° F to 113° F)
- ▶ Day-to-day storage (in plastic container): 16° C to 32° C (60° F to 90° F)
- ▶ Non-condensing relative humidity: 10% to 80% (operating), 20% to 60% (non-operating)
- ▶ Wet bulb temperature should not exceed 26° C (79° F)

Tapes intended for long-term storage should be stored in the plastic containers, at temperatures between 5° C and 23° C (41° F and 73° F) and 20% to 60% relative humidity.

8

TROUBLESHOOTING

In this chapter:

- ▶ “General Procedure” on page 43
- ▶ “Optimizing performance” on page 44
- ▶ “Problems with cartridges” on page 46

GENERAL PROCEDURE

If a problem occurs, the first step is to try to establish whether the problem lies with the cartridge, the drive, the host computer and connections, or the way the system is being operated.

Has the system just been installed?

There could be an installation problem:

1. Check through the information in the relevant installation chapter of this guide.
2. Check the power connectors and SCSI cabling.
3. Is the SCSI ID correctly set? Is there a SCSI system conflict? Has the SCSI bus been correctly terminated?
See “Check the internal drive's SCSI ID” on page 17 and “Check the external drive's SCSI ID” on page 25.
4. Are appropriate drivers and application software installed on the host?
5. Check the environmental conditions against the specified limits.

Table 8-1 Environmental specifications for LTO tape drives

	Temperature range	Non-condensing humidity range
Operating	50° to 95° F (10° to 40° C) at a minimum of 6 CFM airflow	20 to 80% RH (non-condensing)
Storage	-40° to 151° F (-40° to 66° C)	10 to 95% RH (non-condensing)

Are you using new cartridges or a different brand of cartridge? Have you been using the particular cartridge for a very long time?

The problem could lie with the cartridge:

1. Check through the media chapter on “[Use the correct media](#)” on page 37.
2. Check that you are using an Ultrium cartridge. Compatible media can be recognized by the LTO logo, which is the same as the logo on the front of your drive.
3. Use the correct media type, for example:
 - ▶ Ultrium 1.6 TB RW and Ultrium 1.6 TB WORM tape cartridges for use with LTO-4 tape drives.
 - ▶ Ultrium 800 GB RW and Ultrium 800 GB WORM tape cartridges for use with LTO-3 tape drives.
 - ▶ Ultrium 400 GB RW tape cartridges for use with LTO-2 tape drives.
4. Has the cartridge been write-protected, see “[Write protecting cartridges](#)” on page 40?
5. Clean the tape heads with the cleaning cartridge, see “[Cleaning cartridges](#)” on page 37. Make sure you are using the Ultrium Universal Cleaning Cartridge.
6. Try the operation again.
7. If the problem still occurs, try using a different cartridge.
8. If the problem is still there, the problem probably lies with the drive or the host computer.

Has the drive been moved recently? Have any cables been disconnected and reconnected? Has the environment changed—unusually hot, cold, damp or dry? Has there been dust or dirt near the drive. Have reasonable precautions against static been taken?

The problem could lie with the drive:

1. Check the cables and connectors.
2. Clean the tape heads with the cleaning cartridge.
3. If the problem persists, check the environmental conditions against the specified limits, see [Table 8-1](#) on page 43 or refer to <http://www.tandbergdata.com>. Perhaps move the drive to a more suitable site.

Has a new operating system been installed in the host computer? Has new backup software been installed?

The problem could lie with the host or the software. Consult the computer’s operating manuals, the software manual, or seek help from a service engineer.

OPTIMIZING PERFORMANCE

Various factors can affect tape drive performance, particularly in a network environment. In nearly all cases when performance is not as expected, it is the data rates of the disk subsystem that cause the bottleneck.

If your tape drive is not performing as well as expected—for example, if backup windows are longer than expected—please consider the following points before contacting Technical Support.

▶ Disk subsystem

A single spindle disk will not be able to deliver good data throughput for an LTO-3 tape drive at any compression ratio. To maximize the

capability of these tape drives, utilize aggregated disk sources (RAID) with multiple disk spindles.

A single spindle disk may be sufficient for an LTO-2 tape drive, depending on your data's compressibility. Best practice to ensure good throughput is to utilize multiple disk spindles or data sources.

▶ **System architecture**

Be aware of the architecture of your data protection environment; multiple clients backed up over a network may mean you are unable to take advantage of the LTO-4 or LTO-3 tape drive because the Ethernet infrastructure connecting such systems may limit performance.

For LTO-2 tape drives, the aggregation of multiple client sources over a network provides a good way of delivering good performance, but anything less than Gigabit Ethernet may limit performance for LTO-2 tape drives.

Some enterprise class backup applications can be made to interleave data from multiple sources, such as clients or disks, to keep the tape drive working at optimum performance.

▶ **Tape media type**

The data cartridge should match the specification of the tape drive. A lower specification will have a lower transfer speed (see “[Data cartridges](#)” on page).

▶ **Data and file types**

The type of data being backed up or restored can affect performance. Typically, small files incur greater overhead in processing and access than large files. Equally, data that is not compressible will always limit the speed at which the drive can write/read data. You will achieve no more than native rates with uncompressible data.

Examples of files that compress well are plain text files, spreadsheets; those that compress poorly are those that are either compressed as part of their format (such as, JPEG photographic files) or stored as compressed (such as, .ZIP files or .gz/.Z files on Unix platforms).

Is the tape drive on a dedicated SCSI bus?

We recommend that the tape drive is the only device on the SCSI bus. If it is not, ensure that other devices are LVD compliant. If they are single-ended, the bus will switch to single-ended mode with a lower transfer speed. There will also be restrictions on cable length.

Can your system deliver the required performance?

- ▶ The LTO-4 tape drive can write uncompressed data at up to 80 MB/s (288 GB/hour).
- ▶ The LTO-3 tape drive can write uncompressed data at up to 60 MB/s (216 GB/hour) or compressed data at up to 120 MB/s (432 GB/hour), assuming 2:1 compression.
- ▶ The LTO-2 tape drive can write uncompressed data at up to 24 MB/s (86 GB/hour) or compressed data at up to 48 MB/s (172 GB/hour), assuming 2:1 compression.

To obtain this performance it is essential that your whole system can deliver this performance. In most cases, the backup application will provide details of the average time taken at the end of the backup.

Typical areas where bottlenecks can occur are:

▶ **Disk subsystem**

A single spindle disk will not be able to deliver good data throughput for an LTO-4 or LTO-3 tape drive at any compression ratio. To maximize the capability of these tape drives, utilize aggregated disk sources (RAID) with multiple disk spindles.

A single spindle disk may be sufficient for an LTO-2 tape drive, depending on your data's compressibility. Best practice to ensure good throughput is to utilize multiple disk spindles or data sources.

▶ **System architecture**

Be aware of the architecture of your data protection environment; multiple clients backed up over a network may mean you are unable to take advantage of the LTO-4 or LTO-3 tape drive because the Ethernet infrastructure connecting such systems may limit performance.

For LTO-2 tape drives, the aggregation of multiple client sources over a network provides a good way of delivering good performance, but anything less than Gigabit Ethernet may limit performance for LTO-2 tape drives.

Some enterprise class backup applications can be made to interleave data from multiple sources, such as clients or disks, to keep the tape drive working at optimum performance.

▶ **Tape media type**

The data cartridge should match the specification of the tape drive. A lower specification will have a lower transfer speed (see “[Data cartridges](#)” on page). Use:

- ▶ Ultrium 1.6 TB R/W or Ultrium 1.6 TB WORM cartridges with LTO-4 tape drives
- ▶ Ultrium 800 GB R/W or Ultrium 800 GB WORM cartridges with LTO-3 tape drives
- ▶ Ultrium 400 GB R/W cartridges with LTO-2 tape drives

▶ **Data and file types**

The type of data being backed up or restored can affect performance. Typically, small files incur greater overhead in processing and access than large files. Equally, data that is not compressible will always limit the speed at which the drive can write/read data. You will achieve no more than native rates with uncompressible data.

Examples of files that compress well are plain text files, spreadsheets; those that compress poorly are those that are either compressed as part of their format (such as, JPEG photographic files) or stored as compressed (such as, .ZIP files or .gz/.Z files on Unix platforms).

PROBLEMS WITH CARTRIDGES

If you experience any problems using LTO branded cartridges, check:

- ▶ The cartridge case is intact and that it contains no splits, cracks or damage.
- ▶ The cartridge has been stored at the correct temperature and humidity. This prevents condensation. See the insert included with the tape cartridge for storage conditions.
- ▶ The write-protect switch is fully operational. It should move from side to side with a positive click.

The cartridge is jammed

If the cartridge is jammed or the backup application is unable to eject it, you can force eject the cartridge. If the failure occurs regularly, contact Technical Support.

1. Either press and hold the Eject button on the front of the tape drive for at least 10 seconds.
2. Wait for the cartridge to be ejected. This process may take up to 10 minutes (the maximum rewind time). It is important that you allow sufficient time for the drive to complete this process. If you interrupt it, you may damage the media or the tape drive. The drive is then reset as though you had turned the power off and then on again.

You may lose data if you force eject a cartridge. The tape may also become unreadable because an EOD (End of Data) mark may not be properly written.

3. If the cartridge is still jammed, the tape drive has failed, contact Technical Support.

The drive will not accept the cartridge (or ejects it immediately)

The cartridge may have been damaged, for example dropped, or the drive may have a fault. If it is a cleaning cartridge, it has probably expired and should be discarded immediately. For data cartridges:

1. Check that the drive has power (the power cable is properly connected and the Ready LED is on).
2. Check that you are using the correct media. Use only Ultrium media, (see [“Use the correct media”](#) on page 37).
3. Make sure that you have loaded the cartridge with the correct orientation (see [“Loading a cartridge”](#) on page 35).
4. Check for damage to your media and discard it if it is damaged.
5. Use a new or known, good piece of media and see if it loads. If it does, the original cartridge is faulty and should be discarded.
6. Check if another LTO drive of the same model will accept the cartridge. If it does, the original drive may be faulty. Before calling customer service, please check that the tape drive is responding.

NOTES

A

SCSI CONFIGURATION GUIDE

SCSI IN LTO DEVICES

LTO-4 and LTO-3 tape drives are high performance Ultra320 SCSI compatible devices; LTO-2 tape drives are high performance Ultra160 SCSI compatible devices.

They are designed to operate on a low voltage differential (LVD) SCSI interface and are not compatible with high voltage differential (HVD) SCSI devices.

LTO-4 and LTO-3 tape drives support a burst transfer rate of 320 MB/sec; LTO-2 tape drives support a burst transfer rate of 160 MB/sec.

To benefit from this level of performance, it is important to ensure that the drives are connected to a SCSI bus of a similar or higher specification. This means that you need:

- ▶ **An Ultra320 bus for LTO-4 and LTO-3 tape drives. An Ultra160 or Ultra320 bus for LTO-2 tape drives.**
If you attach the drive to a lower specification SCSI bus, it will still work but data may not be transferred as quickly. Ultra2 SCSI is also supported, but performance may be degraded.
- ▶ **LVD-rated SCSI cabling and terminators.** The LVD interface enables the data to be transferred at the drive's maximum rate and provides a maximum cable length of 12 meters.

Daisy chaining devices

Note: We do not recommend daisy chaining an LTO-4 or LTO-3 tape drive with other devices.

If you need to connect multiple devices to the bus, performance may be restricted if there are too many devices on the bus that are accessed simultaneously. Connecting devices of lower SCSI specification, such as Ultra2 or Ultra SCSI, may also restrict performance to your tape drive. Using Single Ended 8-Bit SCSI devices on the same bus is not recommended, as performance will be severely impacted and complicated bus configuration is required to overcome bus termination issues.

Make sure that the last device on the SCSI bus is terminated. We recommend that you do not attach the tape drive to the same SCSI bus

as the disk drive. See [SCSI termination](#) for more information about terminating LTO tape drives.

SCSI TERMINOLOGY

SCSI is a bus interface: all the devices are connected to a single cable (some of this may be inside and some outside the host computer's case). The connection to the host itself is known as the Host Bus Adapter (HBA). You can have several HBAs in a single computer, each with its own SCSI bus: this is a common arrangement in high-performance servers. Some host bus adapters (such as the LSI Logic LSI22320-R) have more than one SCSI bus available on a single card.

Various terms are used when describing SCSI devices. These terms relate to the factors that affect performance and cable length:

- ▶ The speed of the data bus, which may be Fast, Ultra, Ultra2, Ultra3, Ultra160 or Ultra320.
- ▶ The width of the data bus, which may be Narrow or Wide (16-Bit or 8-Bit).
- ▶ The voltage level of the interface, which may be single-ended (SE) or low voltage differential (LVD).

SETTING UP THE SCSI BUS

Each device on a SCSI bus, including the SCSI host bus adapter (HBA), must be configured with a unique ID (identifier). The SCSI bus must be terminated.

Note: We recommend that a dedicated host bus adapter is used for the tape drive. A suitable adapter is available from your supplier.

SCSI ID numbers

For wide SCSI buses, the SCSI ID will be a number from 0 through 15, so a typical wide SCSI HBA can accommodate up to fifteen other devices. (On narrow SCSI buses, the SCSI ID is a number from 0 through 7.)

Narrow: 7 6 5 4 3 2 1 0
 High ——— priority ——— Low
Wide: 7 6 5 4 3 2 1 0 15 14 13 12 11 10 9 8

Each device must have a unique SCSI ID. The drive can be assigned any unused ID between 0 and 15. Do not use SCSI ID 7, which is reserved for the SCSI controller. SCSI ID 0 is typically assigned to the boot disk and should also not be used unless the tape drive is on a dedicated SCSI bus.

SCSI ID 7 is normally reserved for the HBA because it has the highest priority on the bus. On wide buses, the priority runs from 7 (highest) to 0, then 15 down to 8 (lowest).

Note: As a general rule, avoid putting tape devices on the same bus as any hard disks.

IDENTIFYING SCSI IDs

If your computer already has devices connected to the SCSI bus, you will need to know their IDs to avoid any conflict with the new tape drive. Here are some methods of finding out the information:

- ▶ Most computers display a list of SCSI devices and IDs during the boot-up process. This usually scrolls past very fast. If you press the [Pause] key, you should be able to halt the scrolling and view the list.
- ▶ On Windows systems, you can use Device Manager.
- ▶ If you have Novell NetWare installed, use its LIST DEVICES command.

If none of these is available to you, try the following sources of information:

- ▶ The details of all installed devices and settings may have been written down and stored with your computer's documentation (for new computers, this is often done by the supplier).
- ▶ Your HBA's documentation should tell you which settings it uses.
- ▶ Look at each device to find out its ID. This is usually easy with external devices. With internal devices, you will probably need the help of the device's documentation to identify the SCSI ID setting, which is usually set with jumpers.

SETTING THE SCSI ID ON LTO DRIVES

Note that host adapters check SCSI IDs only at power-on, so any changes will not take effect until the host system is power-cycled.

- ▶ On internal LTO tape drives, set the SCSI ID by attaching or removing jumpers at the rear of the drive, see [Check the internal drive's SCSI ID](#).
- ▶ On external LTO tape drives, the ID is displayed on the rear panel and can be set by pressing the little buttons above and below the number (using a ball point pen), see [Check the external drive's SCSI ID](#).

SCSI TERMINATION

Terminators are essential, as they provide the correct voltages on the SCSI bus and prevent unwanted signal reflections from interfering with data transfers. The rule is:

Note: There must be termination at both physical ends of the bus and only at the ends.

There are two main types of termination, active and passive. Active terminators reduce interference and allow faster data throughput. On devices with high transfer speeds, such as LTO devices, active termination is required, using an LVD or multimode active terminator. (Multimode terminators allow both LVD and single-ended devices to be connected to the same bus. They detect the type of bus and automatically supply the correct termination.)

Normally the HBA forms one end of the SCSI bus and provides termination. You only need to ensure that the other end of the bus is terminated.

Internal drives

LTO internal tape drives do not supply termination. A suitably terminated LVD internal ribbon cable is supplied with the tape drive. The terminator is usually a small, rectangular block of plastic attached to the cable end and marked 'SCSI Terminator'.

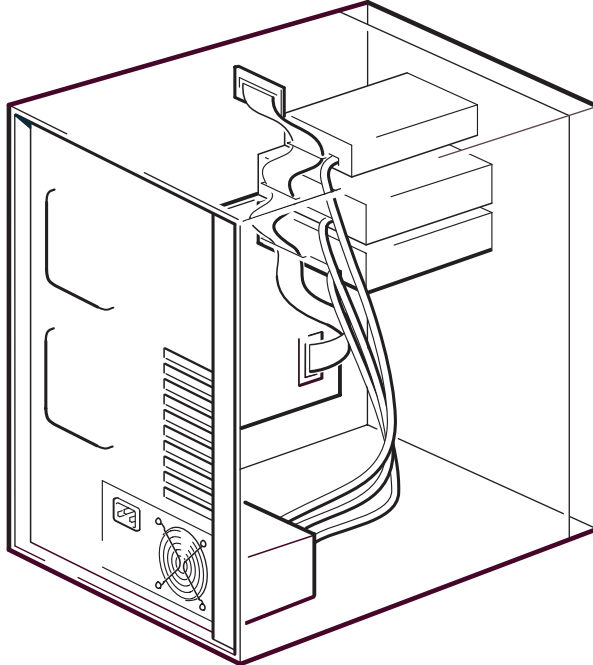

Figure A-1 SCSI termination in internal drives

As long as this terminator is attached, you do not need to take any further action. However, if you have other devices attached to the cable, make sure that they have termination removed or disabled.

Note: If you have an internal and external device attached to the same SCSI bus, the HBA will be in the middle of the cable and thus its termination must be disabled. See the host bus adapter's documentation for details of how to do this.

External drives

For LTO external tape drives the enclosure provides active termination.

As long as the drive is the only device on the SCSI chain, no terminators are required. The green ACT Term LED on the rear of the drive indicates whether auto-termination is active (on) or not (off).

Make sure the terminator is firmly attached to the SCSI-OUT connector on the rear of the device when you install it.

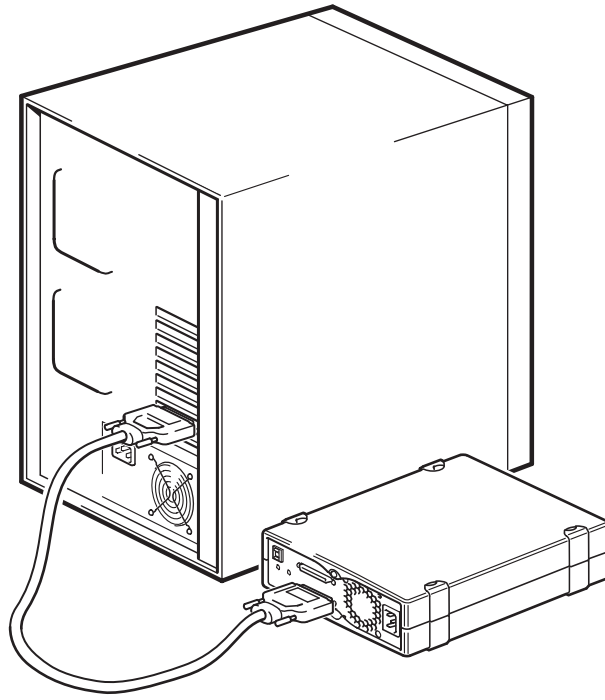

Figure A-2 SCSI termination on a single LTO tape drive

If you have more than one device on the SCSI bus, daisy-chain them by connecting an LVD-rated cable from the SCSI-OUT connector on the first device to the SCSI-IN connector on the second device. Assuming you have two LTO tape drives connected, the enclosure on the second drive provides termination. The green ACT Term LED on the rear of the first drive will be off while on the rear of the second drive it will be on. If the second device is not an LTO external drive, make sure that it is terminated using an LVD-rated multimode terminator.

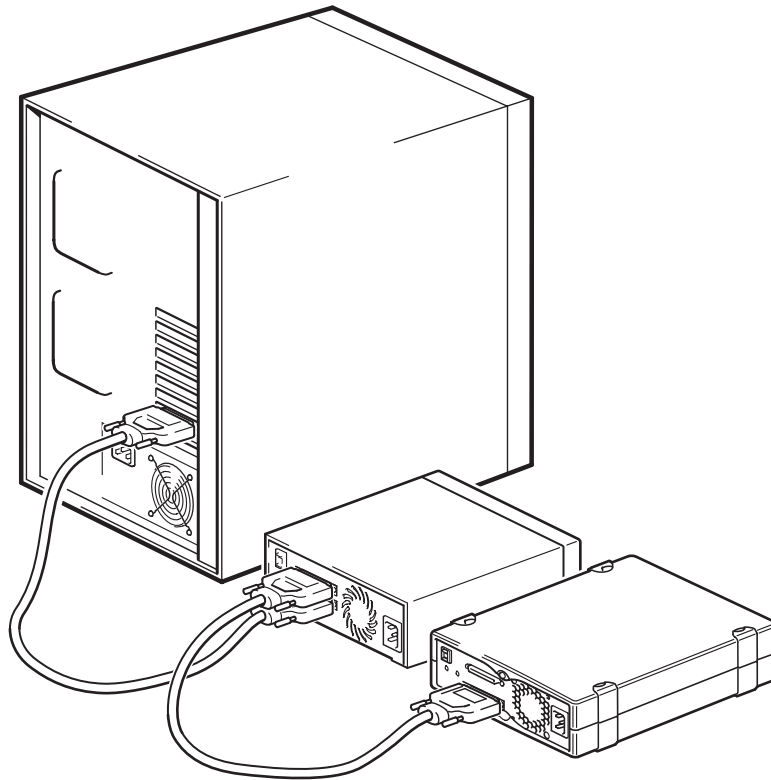

Figure A-3 SCSI termination in daisy-chained external drives

SCSI CABLES

Cables matter in SCSI systems. There are two factors to consider: cable length and cable quality.

Cable length

- ▶ For LVD SCSI the maximum length for a single device is 25 meters. For multiple devices, the maximum combined internal/external length is 12 meters.
- ▶ If you have a combination of LVD and SE devices on the bus, the maximum cable length reverts to the SE specification. This is 3 meters for four or fewer devices, and 1.5 meters for more than four devices. See also note below on SE and LVD interfaces.
- ▶ For best performance, keep lengths to a minimum, but avoid very short overall lengths (less than 0.5 meters).

Cable quality

- ▶ It is important to use good quality cables. Generally speaking, cable quality affects performance and reliability. This is particularly true for external, shielded cables.
- ▶ Look after your SCSI cables. In particular, take care when connecting or disconnecting not to damage the high-density connectors. Avoid putting excessive twists in external shielded cables, as this can cause premature failure.

With internal devices

LTO tape drives have a 68-pin wide, high-density SCSI connector. A suitable cable with the correct termination is supplied with the tape drive. If

you are using an LTO drive on an internal bus with other peripherals that run at Ultra2 speeds, it is important that a 68-pin LVD-compatible ribbon cable is used. Do not connect your tape drive to lower-rated SCSI or to narrow SCSI.

With external devices

Your tape drive requires a 68-pin VHD-to-HD SCSI cable to connect to the host server.

Note on SE and LVD interfaces

SE and LVD define how the signals are transmitted along the cable.

- ▶ With single-ended (SE) SCSI, each signal travels over a single wire and each signal's value is determined by comparing the signal to a paired ground wire. Signal quality tends to decrease over longer cable lengths or at increased signal speed.
- ▶ With low voltage differential (LVD) signaling, signals travel along two wires and the difference in voltage between the wire pairs determines the signal value. This enables faster data rates and longer cabling with less susceptibility to noise than SE signaling and reduced power consumption.

If you use LVD SCSI devices on the same bus as single-ended devices this will switch the LVD SCSI host adapter into single-ended mode and restrict cable length.

If you connect only LVD SCSI devices, the bus will operate in low voltage differential mode and Ultra160 and higher speeds will be enabled. If you use a combination of Ultra160 and Ultra2 devices, each device will operate at its optimum speed.

NOTES



INDEX

A

audience, VII

B

backup software
 encryption, 15
 supported, 15
backup software problems, 44
buttons
 Unload, 36

C

cartridge
 loading, 35
 unloading, 36
cartridges
 cleaning, 37
 compatibility, 38
 data, 37
 ejected, 47
 encryption, 38
 environment, 42
 handling, 41
 inserting, 35
 jammed, 47
 problems, 44
 removing, 36
 WORM, 38
 write protecting, 40
cleaning
 tape drive, 41
cleaning cartridges, 37
compatibility
 backup software, 15
conventions
 document, VII
 text symbols, VII

D

data cartridges, 37

default SCSI ID, 17, 25

document
 conventions, VII

drive
 front view, 12
 installing, 17
 operating, 35

drivers
 installing, 14
 UNIX, 14
 Windows, 14

E

encryption, 38
 backup software, 15
external drive
 installation, 25

F

firmware, upgrading
 drives, 36
front panel
 LEDs, 31
front view, 12

H

handling cartridges, 41
help
 obtaining, VIII
host
 problems, 44

I

inserting cartridges, 35
install drive, 20

- installation
 - attach mounting hardware, 19
 - external drive, 25
 - guidelines, 9
 - install drive, 20
 - internal drive, 17
 - prepare mounting bay, 18
 - problems, 43
 - reboot (external), 28
 - reboot (internal), 24
 - secure drive, 23
 - verify, 29
- installing
 - drivers, 14
- internal drive
 - installation, 17
- J**
 - jammed cartridge, 47
- L**
 - LEDs, 31
 - troubleshooting, 31
 - loading
 - cartridge, 35
- M**
 - media, 37
 - mounting bay, 18
 - mounting hardware, 19
- O**
 - operating systems, 9
 - operation
 - drives, 35
 - optimizing performance, 44
- P**
 - performance
 - optimizing, 44
 - power specification, 12
- S**
 - SCSI ID
 - default, 17, 25
 - secure drive, 23
 - supported models, 9
 - symbols in text, VII
- T**
 - tape drive
 - cleaning, 41
 - technical support, VIII
 - text symbols, VII
 - troubleshooting
 - cartridges, 46
 - general procedure, 43
 - LEDs, 31
 - optimizing performance, 44
- U**
 - UNIX
 - drivers, 14
 - Unload button, 36
 - unloading
 - cartridge, 36
 - upgrading firmware
 - drives, 36
- V**
 - verify installation, 29
- W**
 - WORM cartridges, 38
 - write protection, 40