



AX4-5 Series

iSCSI Supported Configurations Overview

January 4, 2008

This document contains an overview of the configuration rules for AX4-5 series iSCSI storage systems.

Note: A "storage system" is called an "array" in the AX4-5 support matrix.

Topics include:

◆ Operating system support	2
◆ Path management support.....	2
◆ Hardware support	3
◆ iSCSI configuration rules.....	4
◆ Sample configurations	7

Operating system support

The following operating systems are supported:

- ◆ AIX 5.2, 5.3, and 6.1
- ◆ HP-UX 11.11 and 11.23
- ◆ Linux:
 - RedHat 4.0 and 5.0
 - Novell SUSE 9 and 10
- ◆ Solaris 10 (SPARC and x86)
- ◆ VMware ESX Server 3 and 3.5
- ◆ Windows 2000
- ◆ Windows Server 2003

For details on operating system and cluster support, refer to the support matrix on the AX4-5 support website.

Path management support

A path is a connection between a NIC or iSCSI HBA port and a target SP port in a storage system. Each NIC or iSCSI HBA port that is connected directly or through a network to an SP port is an initiator of that SP port.

For supported native path management or vendor path management software such as EMC[®] PowerPath[®] software, refer to the support matrix on the AX4-5 support website.

Hardware support

This section lists the hardware supported for AX4-5 environments.

Storage-system disk support

An AX4-5SCi can have a maximum of 12 disks; they must be SATA disks. An AX4-5i *without* the expansion pack installed can have a maximum of 12 disks; they must be SATA disks. An AX4-5i *with* the expansion pack installed can have up to 4 disk-array enclosures (DAE-AXs) for a maximum of 60 SATA and/or SAS disks, provided disks 0-3 (the system disks) are either all SATA or all SAS disks.

Server hardware support

We support connection of the following vendors' servers to AX4-5 series storage systems:

- ◆ Bull
- ◆ Dell
- ◆ FSC
- ◆ HP
- ◆ IBM
- ◆ Intel
- ◆ NEC
- ◆ Sun

For additional hardware vendors and details about the supported server hardware, refer to the support matrix on the AX4-5 support website.

Network interface card (NIC) support

Any industry standard 10/100/1000 NIC, which conforms to IEEE 802.3ab, 802.3ac, or 802.3u or is on the Microsoft HCL, should interoperate with an AX4-5SCi or AX4-5i. For details, refer to the support matrix on the AX4-5 support website.

iSCSI host bus adapter (HBA) support

We support the use of the QLogic iSCSI HBA with an AX4-5SCi or AX4-5i. For more information on the support for this iSCSI HBA, refer to the support matrix on the AX4-5 support website.

Ethernet switch and router support

Any industry standard 100/1000 managed or unmanaged Ethernet switch or router should interoperate with an AX4-5SCi or AX4-5i.

iSCSI configuration rules

For configurations with an AX4-5SCi or AX4-5i, we strongly recommend that you use dedicated storage networks, but not required. We can connect servers to an AX4-5SCi or AX4-5i using a Layer 2 (switched) or Layer 3 (routed) network. We support the use of VPNs on the network as long as the network quality is adequate; the presence of VPNs should be transparent to the storage system.

Network switch, router, NIC, and iSCSI HBA rules

When you set up a configuration with an AX4-5SCi or AX4-5i, follow these rules:

- ◆ If you use multiple NICs in a server to connect to a storage system, we recommend that each be on a different subnet. We do *not* support NIC teaming.
- ◆ You can connect a maximum of four iSCSI HBAs per server to an AX4-5SCi or AX4-5i. Note that we support iSCSI HBA connections to an AX4-5SCi or AX4-5i only for some operating systems. For details on operating systems for which we support iSCSI HBAs, refer to the support matrix on the AX4-5 support website.
- ◆ You cannot use both NICs and iSCSI HBAs to connect a server to the same storage system or to different storage systems.
- ◆ You can use NICs in one server and iSCSI HBAs in another server to **connect to the same storage system.**

- ◆ In the same server, you cannot use NICs or iSCSI HBAs to connect to an iSCSI storage system and Fibre Channel HBAs to connect to a Fibre Channel storage system.
- ◆ You can connect a server to a maximum of four AX4-5 series and AX series storage systems, but you cannot connect any other type of storage system to that server. The Navisphere® management software must be the same for all storage systems connected to the server.
- ◆ You can connect a initiator in a server to a maximum of eight SP ports (four AX4-5is) or four SP ports (four AX4-5SCis), but no more than four storage systems.

Environments and configurability

When you set up a configuration with an AX4-5SCi or AX4-5i, follow these rules:

- ◆ You can connect a server to the storage system using 10/100/1000 Mb/s copper (RJ45) connections.
- ◆ For an AX4-5SCi, you can connect a maximum of 10 initiators to an SP, and a maximum of 10 servers to the storage system.
- ◆ For an AX4-5i *without* an expansion pack installed, you can connect a maximum 10 initiators to an SP, and a maximum of 10 servers to the storage system.
- ◆ For an AX4-5i *with* an expansion pack installed, you can connect a maximum of 64 initiators to an SP and a maximum of 64 servers to the storage system.
- ◆ You must configure storage-system target addresses and names manually for the server initiators.
- ◆ You must configure server names and passwords manually in the storage system.
- ◆ For authentication, you can use the optional CHAP (Challenge Handshake Authentication Protocol).

Other considerations

When you set up a configuration with an AX4-5SCi or AX4-5i, take into account these considerations:

- ◆ If multiple NICs in a Windows server are on the same subnet, you must use the MS Initiator "Advanced" configuration setup to take advantage of the additional NICs. If you do not use the "Advanced" configuration, additional NICs are used only in a failover situation.
- ◆ When NICs or iSCSI HBAs are present in the same Windows server, you must use the latest Microsoft iSCSI Initiator listed in the AX4-5 series support matrix to control the iSCSI HBAs.
- ◆ When you use the Microsoft iSCSI Initiator, all NICs in a server use the same iSCSI name. The name identifies the server and the individual NICs are not be identifiable.
- ◆ When you use QLogic iSCSI HBAs, each iSCSI HBA in the server has a unique iSCSI name. The name identifies the individual iSCSI HBA in the server.
- ◆ We do not support dynamic disks for an iSCSI session using the Microsoft iSCSI initiator.
- ◆ For information on booting a server from a virtual disk in an AX4-5SCi or AX4-5i, refer to the support matrix on the AX4-5 support website.
- ◆ For information on current cluster support, refer to the support matrix on the AX4-5 support website.

Backup device support

EMC has tested and qualified only storage area network (SAN) attached backup devices. SAN-attached backup configurations include a backup device connected to a port on the switch. These configurations are not currently customer installable. For supported SAN-attached backup configurations, refer to the support matrix on the AX4-5 support website.

For tape devices connected directly to a backup host, EMC strongly recommends that you review the component vendor's information on supported configurations. Refer to the backup host vendor's information for host compatibility with the SCSI or Fibre Channel interface that connects the host to the tape drive. Refer to the tape

device vendor's information for tape device compatibility with the SCSI or Fibre Channel interface. Refer to the backup software vendor's information for backup software compatibility with the tape device.

Remote replication

You can use the AX4-5 series storage systems with other CLARiiON® storage systems running EMC SAN Copy™ software to replicate data to and from the AX4-5 series storage system with Navisphere management software. For example, an AX4-5 series storage system connected to CX3 series or CX series storage system running SAN Copy can replicate data from branch offices back to the data center to provide disaster recovery protection and to consolidate the backup process. AX4-5 series storage systems can connect to CX3 series or CX series storage systems running SAN Copy through the supported switches listed in the support matrix on the AX4-5 support website.

AX4-5 EMC partners

EMC has a wide variety of distribution partners that offer the AX4-5 series storage systems. The information in this document contains supported components that are standard across our AX4-5 series product solutions. EMC's AX4-5 partners offer a wider variety of the AX4-5 series solutions to fit your business needs. For a complete listing of current EMC distribution partners and their AX4-5 specific solutions, please refer to the EMC website with direct links to these partners. The specific link to this EMC site is:

<http://www.emc.com/partnersalliances/index.jsp>

Sample configurations

This section contains illustrations and descriptions of sample configurations.

Figure 1 shows a configuration that is not highly available. Two single points of failure are the NIC or iSCSI HBA and the SP. PowerPath on the server tells you if the path failed.

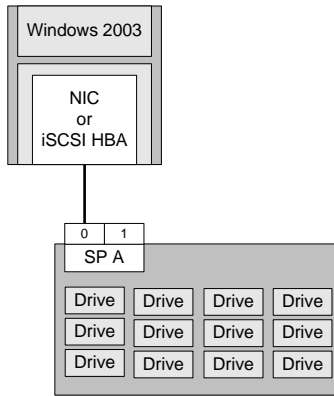

Figure 1 A server with a single NIC or iSCSI HBA connected to one port of the SP

Figure 2 shows a configuration that is not highly available, but that gives two servers access to the storage system. Two single points of failure are the NIC or iSCSI HBA and the SP. PowerPath on each server tells you only if that one path has failed.

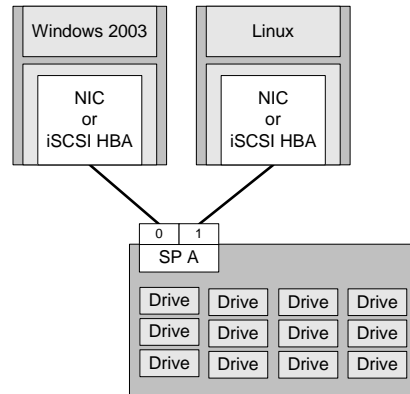

Figure 2 Two servers each with a single NIC or iSCSI HBA connected to different ports on the same SP

Figure 3 shows a highly available configuration with one path to each SP. With PowerPath running on the server, the server can reach any virtual disk if one SP or one NIC or iSCSI HBA fails.

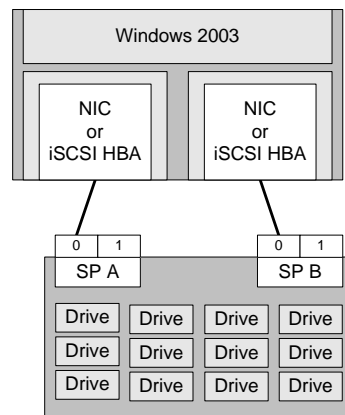

Figure 3 One server with two NICs or iSCSI HBAs connected to a port on each SP

Figure 4 shows a highly available configuration with two paths to each SP (multipath). With PowerPath running on the server, the server can reach any virtual disk if one SP fails or if up to three iSCSI HBAs fail.

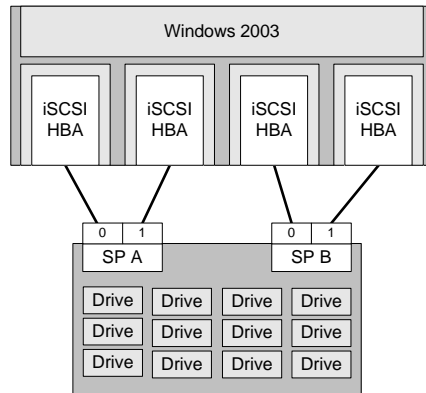

Figure 4 One server with four iSCSI HBAs connected to an SP port on both SPs

Figure 5 shows a configuration that is not highly available. PowerPath running on the server tells you if the path has failed.

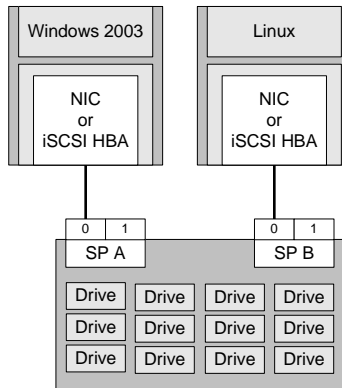

Figure 5 Two servers each with one NIC or iSCSI HBA connected to an SP port on one SP

Figure 6 shows a configuration that is not highly available, but does provide four servers with access to the storage system. Each server has only one path to an SP. PowerPath running on the server tells you if one path has failed.

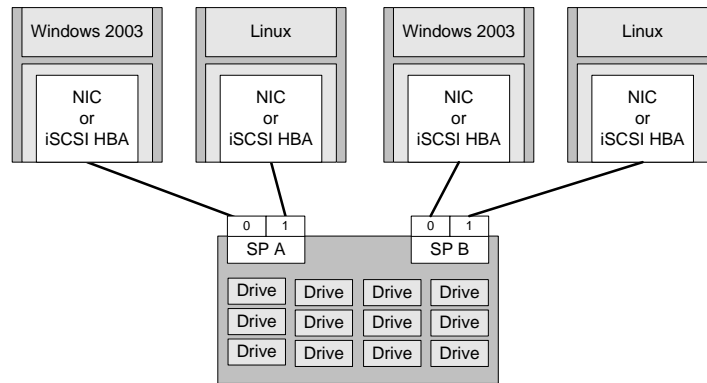

Figure 6 NIC or iSCSI HBA connected to an SP port on one SP

Figure 7 shows a highly available configuration where each server has one path to each SP. With PowerPath running on the server, the server can reach any virtual disk if one SP fails or if one NIC or iSCSI HBA fails.

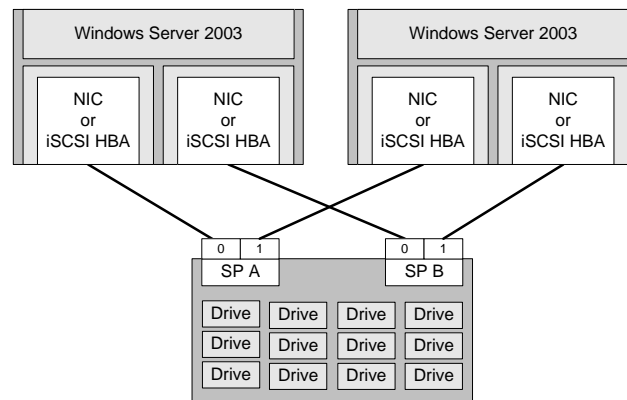

Figure 7 Two servers each with two NICs or iSCSI HBAs connected to an SP port on both SPs

Figure 8 shows a single-network configuration that can support multiple servers, each with one NIC or iSCSI HBA. Each server can reach a port on either SP. The server cannot access the storage system if its NIC or iSCSI HBA fails or if the network fails. With PowerPath running on the server, the server can reach any virtual disk if one SP fails.

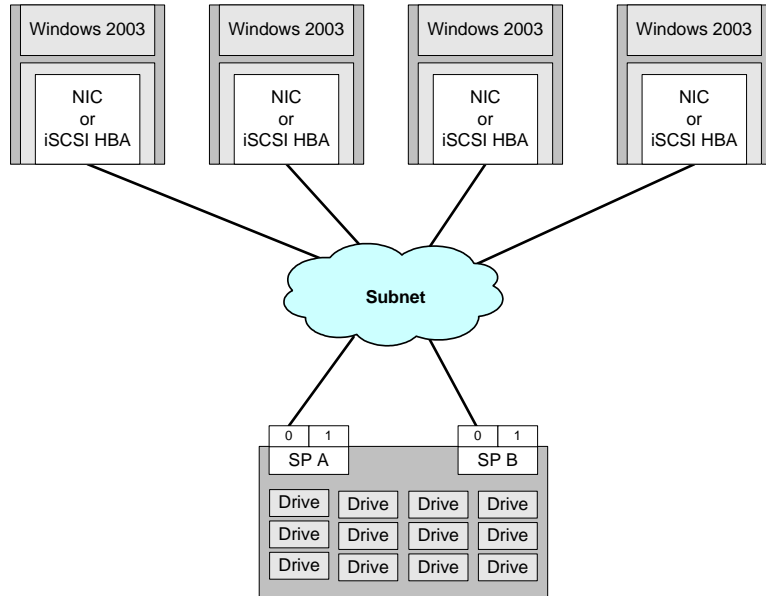

Figure 8 One network and four servers each with one NIC or iSCSI HBA

Figure 9 shows a single-network configuration that is a more highly available configuration than the configuration in Figure 8 because each server has one path to each SP. The network is a single point of failure. With PowerPath running on the server, the server can reach any virtual disk if one SP or one NIC fails.

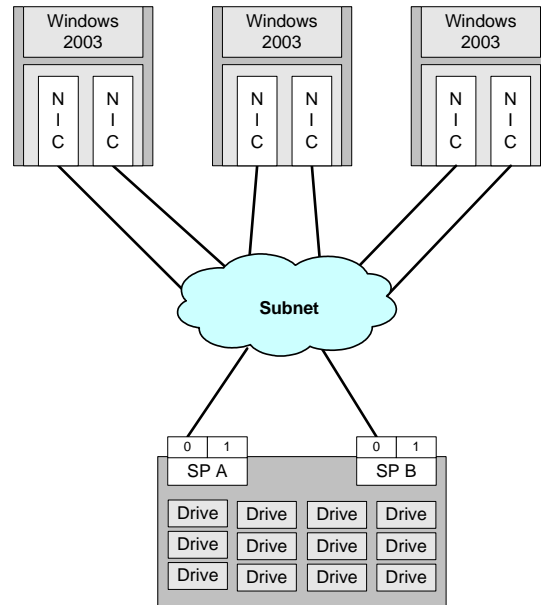

Figure 9 One network with three servers each with two NICs that can reach one SP port on both SPs

Figure 10 shows a dual-network, highly available configuration that can support up to six servers, each with two NICs or iSCSI HBAs. Each server has one path to each SP. With PowerPath running on the server, the server can reach any virtual disk if one SP fails, if one network fails, or if one NIC or iSCSI HBA fails.

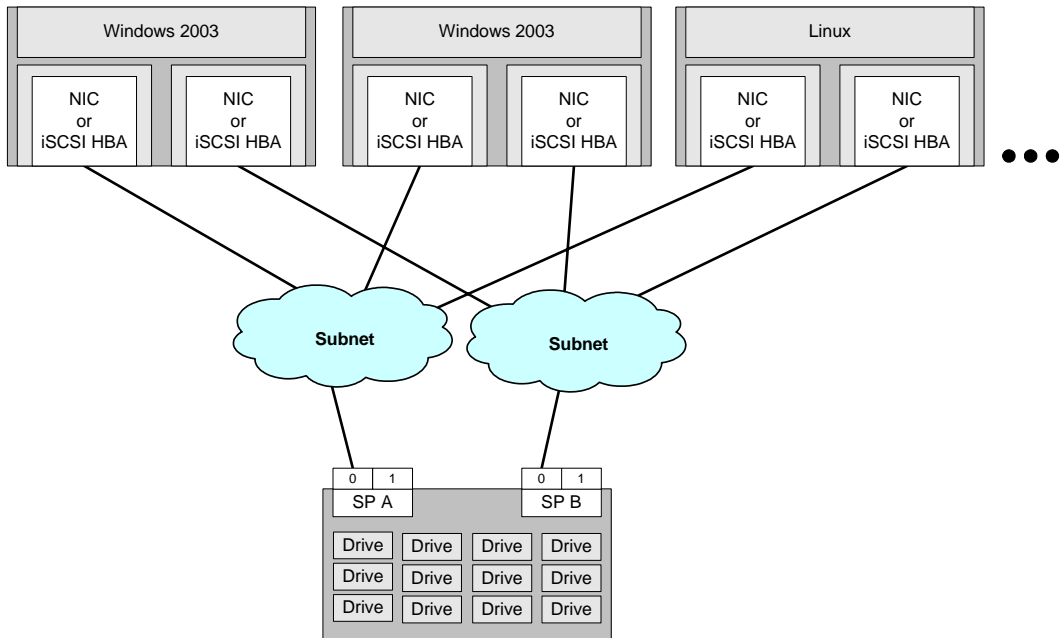

Figure 10 Two networks and multiple servers

Figure 11 shows a dual-network, highly available configuration where each server has two paths to each SP. With PowerPath running on the server, the server can reach any virtual disk if one SP fails, or one network fails, or if one NIC or iSCSI HBA fails.

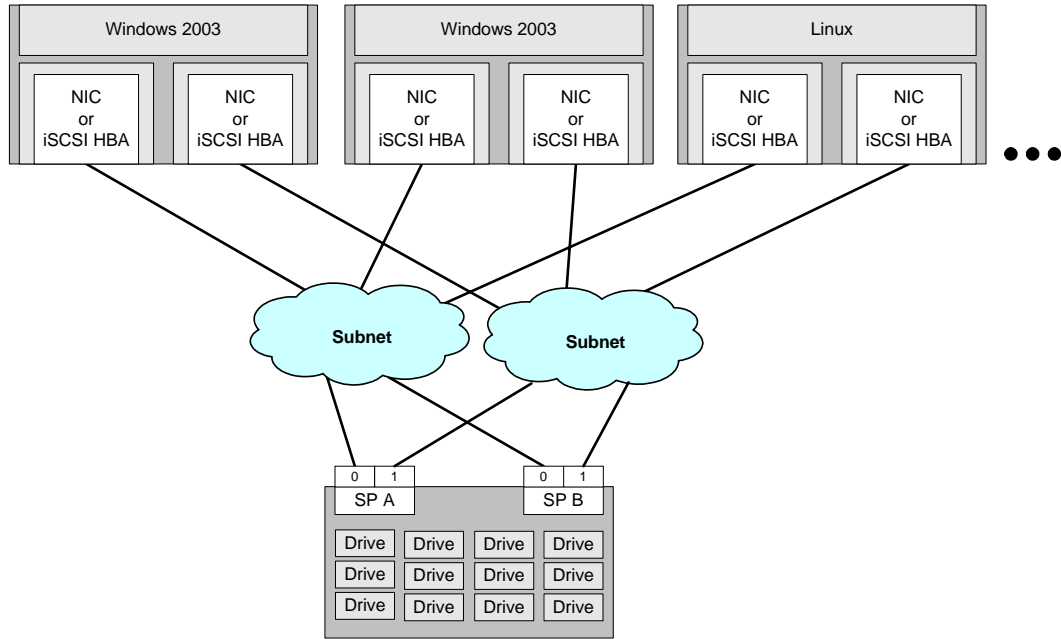

Figure 11 Two networks with multiple servers each with two NICs or iSCSI HBAs that can reach both SP ports on both SPs

Figure 12 shows a dual-network, highly available configuration with the maximum number (4) of storage systems connected to the server. The server can reach each SP through more than one path. With PowerPath running on the server, the server can reach any virtual disk if a storage system's SP fails, or one network fails, or if fewer than four iSCSI HBAs fail.

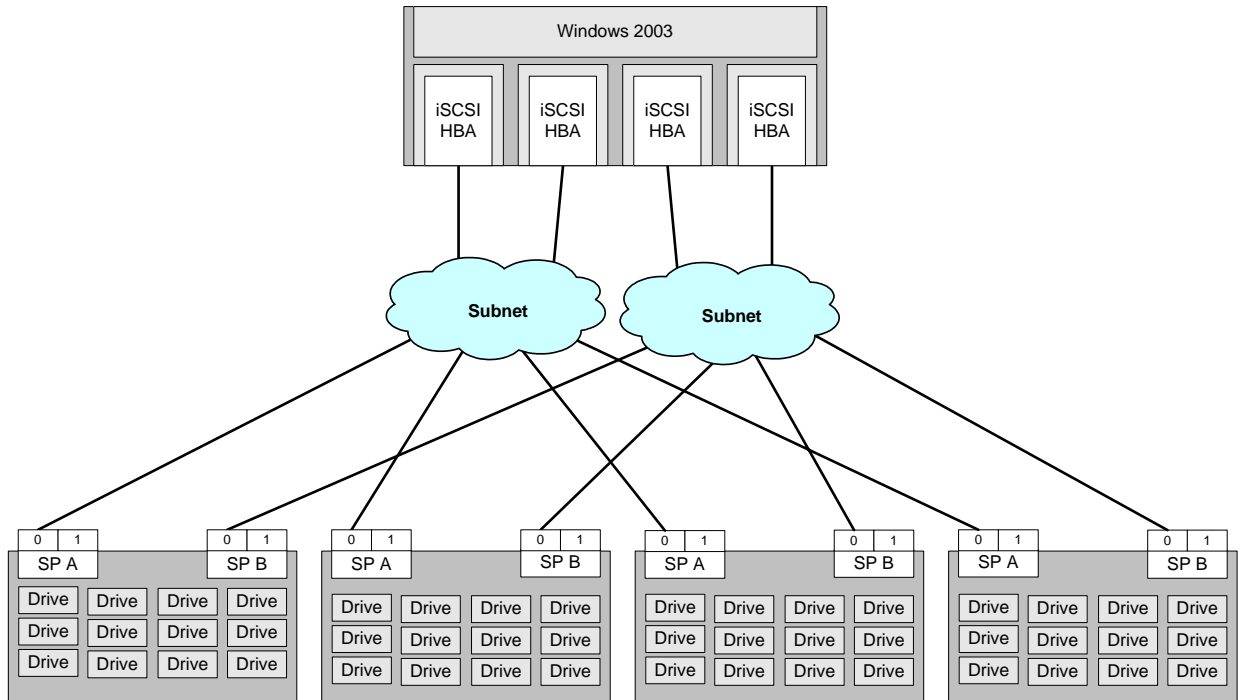

Figure 12 Two networks with one server with four iSCSI HBAs and four storage systems

Copyright © 2008 EMC Corporation. All rights reserved.

EMC believes the information in this publication is accurate as of its publication date. The information is subject to change without notice.

THE INFORMATION IN THIS PUBLICATION IS PROVIDED "AS IS." EMC CORPORATION MAKES NO REPRESENTATIONS OR WARRANTIES OF ANY KIND WITH RESPECT TO THE INFORMATION IN THIS PUBLICATION, AND SPECIFICALLY DISCLAIMS IMPLIED WARRANTIES OF MERCHANTABILITY OR FITNESS FOR A PARTICULAR PURPOSE.

Use, copying, and distribution of any EMC software described in this publication requires an applicable software license.

For the most up-to-date regulatory document for your product line, go to the Technical Documentation and Advisories section on EMC Powerlink.

For the most up-to-date listing of EMC product names, see EMC Corporation Trademarks on EMC.com.

All other trademarks used herein are the property of their respective owners.