



PCI Express® to 6Gb/s Serial Attached SCSI (SAS) Host Bus Adapters

User Guide

June 2012

DB15-000556-09



Revision History

Version and Date	Description of Changes
June 2012	Prepared the document for general distribution.
May 2012	Updated the Maximum Power Requirements table.
January 2012	Added information for the LSI9206-16e host adapter board. Updated the Maximum Power Requirements table. Added the HBA Feature Matrix Appendix. Renamed the LSI9215-8i to the LSI9217-8i host bus adapter board. Renamed the LSI9215-4i4e to the LSI9207-4i4e host bus adapter board.
May 2011	Added information for the LSI9205-8e, LSI9215-4i4e, and LSI9215-8i host adapter boards. Updated document template.
September 2010	Added information for the LSI9202-16e host adapter board.
April 2010	Added information for the LSI9201-16i, and LSI9201-16e host adapter boards.
March 2010	Updated Figure 2, LSI9200-8e Board Layout , on page 10, Figure 3, LSI9210-8i Board Layout , on page 11, Figure 5, LSI9211-8i Board Layout , on page 14, Figure 4, LSI9211-4i Board Layout , on page 13, Figure 6, LSI9212-4i4e Board Layout , on page 16, and Figure 7, LSI9200-16e Board Layout , on page 18.
October 2009	Added information for the LSI9212-4i4e and the LSI9200-16e host adapter boards.
July 2009	Initial release of this document.

LSI, the LSI & Design logo, and Fusion-MPT are registered trademarks or trademarks of LSI Corporation or its subsidiaries. All other brand and product names may be trademarks of their respective companies.

PCI Express and PCIe are registered trademarks of PCI-SIG Corporation. Windows is a registered trademark of Microsoft Corporation. Linux is the registered trademark of Linus Torvalds in the U.S. and other countries. Oracle is a registered trademark of Oracle and/or its affiliates. Red Hat is a registered trademarks of Red Hat, Inc. SUSE and SLES are registered trademarks of Novell, Inc. VMware is a registered trademark of VMware, Inc. FreeBSD is a registered trademark of The FreeBSD Foundation non-profit corporation.

LSI Corporation reserves the right to make changes to the product(s) or information disclosed herein at any time without notice. LSI Corporation does not assume any responsibility or liability arising out of the application or use of any product or service described herein, except as expressly agreed to in writing by LSI Corporation; nor does the purchase, lease, or use of a product or service from LSI Corporation convey a license under any patent rights, copyrights, trademark rights, or any other of the intellectual property rights of LSI Corporation or of third parties. LSI products are not intended for use in life-support appliances, devices, or systems. Use of any LSI product in such applications without written consent of the appropriate LSI officer is prohibited.

Corporate Headquarters
Milpitas, CA
800-372-2447

Email
globalsupport@lsi.com

Website
www.lsi.com

Document Number: DB15-000556-09
Copyright © 2012 LSI Corporation
All Rights Reserved

Table of Contents

Chapter 1: Introduction	4
1.1 Overview	4
1.2 SAS Features	5
1.3 PCI Express Host Interface Features	5
1.4 Software	6
Chapter 2: Hardware Installation	7
2.1 Installation Instructions	7
Chapter 3: Host Bus Adapter Characteristics	9
3.1 Characteristics of the LSI 6Gb/s HBAs	9
3.1.1 LSI SAS9200-8e HBA Characteristics	9
3.1.2 LSI SAS9210-8i HBA Characteristics	10
3.1.3 LSI SAS9211-4i HBA Characteristics	12
3.1.4 LSI SAS9211-8i HBA Characteristics	13
3.1.5 LSI SAS9212-4i4e HBA Characteristics	15
3.1.6 LSI SAS9200-16e HBA Characteristics	16
3.1.7 LSI SAS9201-16e HBA Characteristics	18
3.1.8 LSI SAS9201-16i HBA Characteristics	20
3.1.9 LSI SAS9202-16e HBA Characteristics	22
3.1.10 LSI SAS9205-8e HBA Characteristics	23
3.1.11 LSI SAS9207-8e HBA Characteristics	25
3.1.12 LSI SAS9207-8i HBA Characteristics	26
3.1.13 LSI SAS9207-4i4e HBA Characteristics	27
3.1.14 LSI SAS9217-8i HBA Characteristics	28
3.1.15 LSI SAS9217-4i4e HBA Characteristics	30
3.1.16 LSI SAS9206-16e HBA Characteristics	31
3.2 Environmental Specifications	33
3.2.1 Power Requirements	33
3.2.2 Thermal and Atmospheric Limits	33
3.3 LSI PCIe-to-SAS HBA Certifications and Safety Characteristics	34
Appendix A: HBA Feature Matrix	35

Chapter 1: Introduction

1.1 Overview

The LSI® PCI Express® (PCIe®) to Serial Attached SCSI (SAS) host bus adapters (HBAs) provide four, eight, or sixteen serial ports for connection to SAS and Serial ATA (SATA) devices. Each port is capable of 1.5Gb/s, 3Gb/s, and 6Gb/s link rates for both SAS and SATA. The design of the LSI 6Gb/s HBAs makes it easy to add SAS interfaces to any computer, workstation, or server that has a PCIe bus.

The LSI 6Gb/s HBAs include Flash ROM for storing the firmware and BIOS, and select boards include NVSRAM for storing nonvolatile RAID information.

The LEDs on the HBAs report a heartbeat. The Fusion-MPT™ firmware operates the LSI 6Gb/s HBA.

PCI Express Specification, Revision 2.0 compliant HBAs yield a total bandwidth of 10Gb/s for each full-duplex lane. PCI Express Specification, Revision 3.0 compliant HBAs yield a total bandwidth of 16Gb/s for each full-duplex lane. All PCIe software is backward compliant with previous versions of the PCI and PCI-X specifications. The LSI 6Gb/s HBAs use either a standard PCI bracket or a low-profile, PCI-bracket type.

An LSI controller chip provides the PCIe and SAS functionality of the LSI 6Gb/s HBAs to connect SAS/SATA devices to a computer system through the PCIe interface. The controller chip on each HBA connects directly to the PCIe bus and generates timing and protocol in compliance with the PCIe specification. The controller chip provides the SAS connections to the SAS and SATA devices in the computer system.

The following table shows specification information for each LSI 6Gb/s HBA model. See [Appendix A](#) for a complete LSI 6Gb/s HBA model matrix.

Table 1 LSI PCIe-to-SAS HBA Specification Details

LSI PCIe-to-SAS HBA Model	Controller	PCIe Interface Phys			PCI Express Specification Revision		SAS/SATA Interface Phys		
		x4	x8	x16	2.0, 5Gb/s	3.0, 8Gb/s	x4	x8	x16
LSISAS9200-8e HBA Characteristics	LSISAS2008		x		x			x	
LSISAS9210-8i HBA Characteristics	LSISAS2008		x		x			x	
LSISAS9211-4i HBA Characteristics	LSISAS2004	x			x		x		
LSISAS9211-8i HBA Characteristics	LSISAS2008		x		x			x	
LSISAS9212-4i4e HBA Characteristics	LSISAS2008		x		x			x	
LSISAS9200-16e HBA Characteristics	LSISAS2116		x		x				x
LSISAS9201-16e HBA Characteristics	LSISAS2116		x		x				x
LSISAS9201-16i HBA Characteristics	LSISAS2116		x		x				x
LSISAS9202-16e HBA Characteristics^a	LSISAS2008			x	x				x
LSISAS9205-8e HBA Characteristics	LSISAS2308		x		x			x	
LSISAS9207-8e HBA Characteristics	LSISAS2308		x			x		x	
LSISAS9207-8i HBA Characteristics	LSISAS2308		x			x		x	
LSISAS9207-4i4e HBA Characteristics	LSISAS2308		x			x		x	
LSISAS9217-8i HBA Characteristics	LSISAS2308		x			x		x	
LSISAS9217-4i4e HBA Characteristics	LSISAS2308		x			x		x	
LSISAS9206-16e HBA Characteristics^b	LSISAS2308		x			x			x

a. The LSISAS9202-16e HBA uses two LSISAS2008 controller chips.

b. The LSISAS9206-16e HBA uses two LSISAS2308 controller chips.

1.2 SAS Features

This section lists the SAS features of the LSI 6Gb/s SAS HBAs:

- Supports serial SCSI protocol (SSP), serial ATA tunneling protocol (STP), and serial management protocol (SMP), as defined in the *Serial Attached SCSI (SAS) Specification*, version 2.0.
- Supports SATA, as defined in the *Serial ATA Specification*, version 3.0.
- Provides configurable drive spin-up sequencing on a per-phy basis.
- Simplifies cabling with a point-to-point, serial architecture.
- Provides smaller and thinner cables that promote unrestricted airflow.
- Provides a serial, point-to-point, enterprise-level storage interface.
- Transfers data using SCSI information units.
- Provides compatibility with SATA target devices.
- Supports narrow ports and wide ports, as described in the following table.

Table 2 6Gb/s SAS Bandwidths

Half Duplex	Full Duplex
Narrow port (one lane), 600 MB/s	Narrow port (one lane), 1200 MB/s
Wide port (two lanes), 1200 MB/s	Wide port (two lanes), 2400 MB/s
Wide port (four lanes), 2400 MB/s	Wide port (four lanes), 4800 MB/s

1.3 PCI Express Host Interface Features

This section lists the PCIe host interface features of the LSI 6Gb/s HBAs:

- A single-phy (one lane) link transfer rate up to 8Gb/s in each direction.
- Link widths of x16, x8, x4, and x1.
- Automatic downshift. The LSI SAS9202-16e HBA automatically downshifts to a x8-link width if plugged into a x16 connector that is wired as a x8 connector. Other HBA models automatically downshift to a x4-link if plugged into a x8 connector that is wired as a x4 connector.
- A scalable interface.

Table 3 PCIe Aggregate Bandwidth

Lanes	PCIe 2.0 Operation		PCIe 3.0 Operation	
	Single Direction	Dual Direction	Single Direction	Dual Direction
Single-lane (x1)	5 Gb/s	10 Gb/s	8 Gb/s	16 Gb/s
Quad-lane (x4)	20 Gb/s	40 Gb/s	32 Gb/s	64 Gb/s
Eight-lane (x8)	40 Gb/s	80 Gb/s	64 Gb/s	128 Gb/s
Sixteen-lane (x16)	80 Gb/s	160 Gb/s	128 Gb/s	256 Gb/s

- Serial, point-to-point interconnections between devices.
 - Reduces the electrical load of the connection
 - Enables higher transmission and reception frequencies
- Lane reversal and polarity inversion.
- PCIe hot plug.

- Power management.
 - Supports PCI Power Management 1.2
 - Supports active-state power management (ASPM), including the L0, L0s, and L1 states, by placing links in a power-saving mode when there is no link activity
- A replay buffer that preserves a copy of the data for retransmission in case a cyclic redundancy check (CRC) error occurs.
- PCIe advanced error-reporting capabilities.
- Packetized and layered architecture.
- High bandwidth per pin with low overhead and low latency.
- Software compatibility with PCI and PCI-X software.
 - Leverages existing PCI device drivers
 - Supports the memory, I/O, and configuration address spaces
 - Supports memory read/write transactions, I/O read/write transactions, and configuration read/write transactions
- 4 KB of PCI configuration address space per device.
- Posted transactions and nonposted transactions.
- Quality-of-service (QOS) link configuration and arbitration policies.
- Traffic Class 0 and one virtual channel.
- Message-signaled interrupts (both MSI and MSI-X), as well as INTx interrupt signaling for legacy PCI support.
- End-to-end CRC (ECRC) and advanced error reporting.

1.4 Software

The LSI 6Gb/s HBAs support all major operating systems: Windows®, Linux® Red Hat®, SUSE® Linux Enterprise Server (SLES®), Solaris, VMware®, and FreeBSD®. Refer to <http://www.lsi.com/support/products/Pages/default.aspx> for details on the software versions and device driver support.



NOTE The LSI 6Gb/s HBAs support Solaris 10 and Oracle® provides a built-in driver; installation of an LSI driver is not required. For more information on the Oracle Solaris 10 driver and installation, sign in at the following Oracle link.

<https://support.oracle.com/>

Contact Oracle support for Oracle driver or software support.

Chapter 2: Hardware Installation

2.1 Installation Instructions

The following are the installation instructions for the LSI 6Gb/s HBAs.

1. **Unpack the HBA, and inspect it for damage.** Unpack the HBA in a static-free environment. Remove the HBA from the antistatic bag and carefully inspect it for damage. If you notice any damage, contact LSI or your reseller support representative.



ATTENTION Make a backup of your data before changing your system configuration, or you might risk data loss.

2. **Prepare the system.** Turn off the computer, and disconnect the power cord from the rear of the power supply.



CAUTION Disconnect the computer from the power supply and from any networks before you install the HBA, or you risk damaging the system or electrical shock.

3. **Remove the cover from the chassis.**
4. **Insert the HBA in an available PCIe slot.** Locate an empty PCIe slot. Remove the blank bracket panel on the rear of the computer that aligns with the empty PCIe slot. Save the bracket screw, if applicable.

Align the HBA to a PCIe slot. Press down gently, but firmly, to properly seat the HBA in the slot. The following figure shows how to insert the HBA in a PCIe slot.

Figure 1 Installing an LSI 6Gb/s x8 HBA in a PCI Express Slot

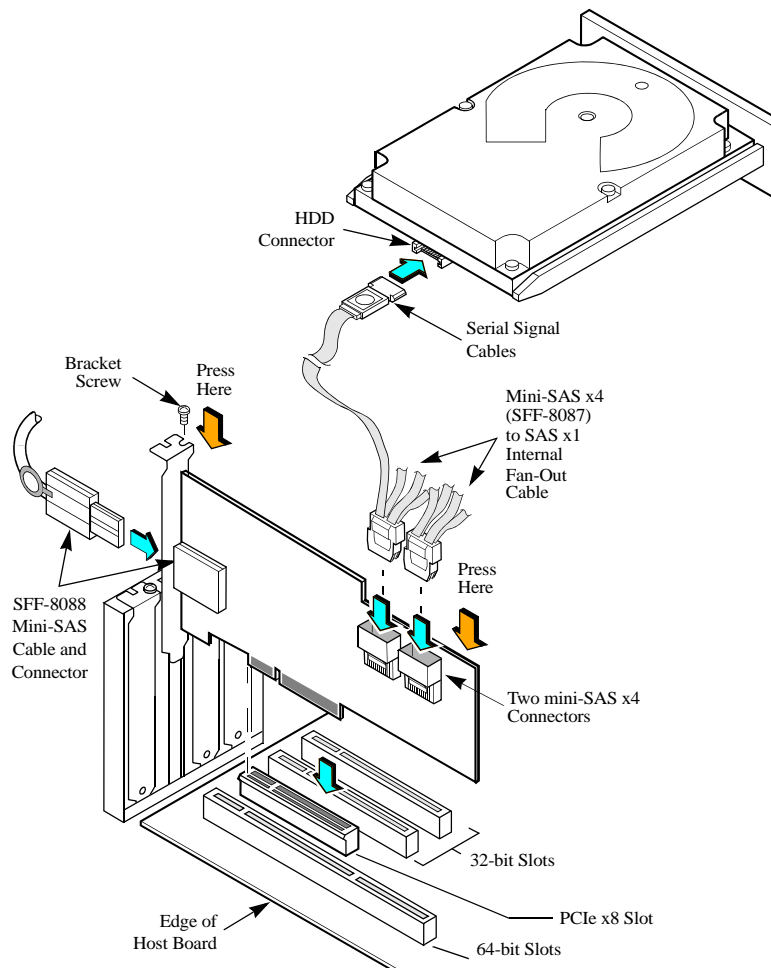

NOTE The shape, size, and locations of components on your HBA and its bracket might vary from this illustration. The LSI SAS9202-16e HBA requires a x16 PCIe slot. The LSI SAS9211-4i HBA requires a x4 PCIe slot. The LSI SAS9211-4i HBA can be up-plugged into a x8 slot or a x16 slot.

5. **Secure the bracket to the system's chassis.** Install the bracket screw, if applicable, or engage the system retention mechanism to secure the HBA to the system's chassis.
6. **Connect SAS cables between the HBA, the SAS backplane, other SATA or SAS devices, or the SAS enclosure that contains the SATA or SAS devices.** Figure 1 shows the locations of the connectors on an HBA.
7. **Replace the cover and any power cords and power up the system.** Replace the chassis's cover, reconnect any power cords, and reconnect any network cables. Turn on the power.

The hardware installation of your LSI 6Gb/s HBA is complete.

Chapter 3: Host Bus Adapter Characteristics

3.1 Characteristics of the LSI 6Gb/s HBAs

The following sections present the memory, LED, connector, and physical characteristic information for each LSI 6Gb/s HBA.

3.1.1 LSISAS9200-8e HBA Characteristics

3.1.1.1 Memory

The LSISAS9200-8e HBA provides one 4-M × 8-bit Flash ROM for storing the firmware and BIOS.

3.1.1.2 LEDs

The LSISAS9200-8e HBA has a 4-pin header for connection of activity LEDs. The 4-pin header connects to two LEDs (see [Table 4](#)), which indicate SAS activity on Port 0 and Port 1.

3.1.1.3 Connectors

This section describes the different connectors on the LSISAS9200-8e HBA. See [Figure 2](#) for connector locations.

PCIe Connector (J7). The LSISAS9200-8e HBA supports a x8 interface. The PCIe host interface connection is through the edge connector, J7, which provides connections on both the top (J7B) and bottom (J7A) of the board. The signal definitions and pin numbers conform to the PCIe specification.

SAS/SATA Connectors (J4 and J5). The LSISAS9200-8e HBA supports SAS/SATA connections through connectors J4 and J5, which are SFF-8088 mini-SAS, external, right-angle connectors.

Activity LED Header (J3). The LSISAS9200-8e HBA has a 4-pin, right-angle, 0.1-in. pitch header for driving external activity LEDs.

Table 4 LSISAS9200-8e LED Header

Pin	Function
1	3.3 V
2	Port 0
3	Port 1
4	3.3 V

UART Connector (TP2). The UART connector debug port requires a special cable and LSI support to gather detailed Input/Output Controller (IOC) status.

Table 5 LSISAS9200-8e UART Pinout

Pin	Function
1	UART0_TX
2	Gnd
3	UART0_RX
4	3.3 V

3.1.1.4 Physical Characteristics

The LSISAS9200-8e HBA is a 6.6-in. × 2.7-in., low-profile board. The component height on the top and bottom of the LSISAS9200-8e HBA is in accordance with the PCIe specification.

Figure 2 LSISAS9200-8e Board Layout

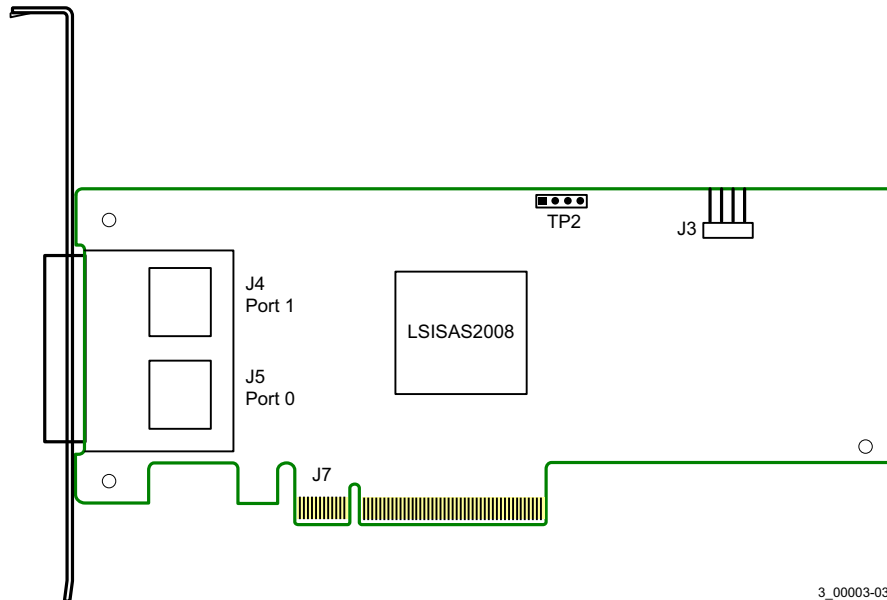

- J7: PCIe x8-lane board edge connector
- J4, J5: SFF-8088 mini-SAS, external, right-angle connectors
- J3: 4-pin, right angle, 0.1-in. pitch pin header for driving external activity LED
- TP2: UART connection

3.1.2 LSISAS9210-8i HBA Characteristics

3.1.2.1 Memory

The LSISAS9210-8i HBA provides one 4-M × 8-bit Flash ROM for storing the firmware and BIOS. The LSISAS9210-8i HBA can provide up to 32 K × 8-bit NVSRAM for storing nonvolatile RAID information when a system failure occurs.

3.1.2.2 LEDs

The LSISAS9210-8i HBA has a 4-pin header for connection of activity LEDs. The 4-pin header connects to two LEDs (see [Table 6](#)), which indicate SAS activity on Port 0 and Port 1.

3.1.2.3 Connectors

This section describes the different connectors on the LSISAS9210-8i HBA. See [Figure 3](#) for connector locations.

PCIe Connector (J6). The LSISAS9210-8i HBA supports a x8 interface. The PCIe host interface connection is through the edge connector, J6, which provides connections on both the top (J6B) and bottom (J6A) of the board. The signal definitions and pin numbers conform to the PCIe specification.

SAS/SATA Connectors (J4 and J5). The LSISAS9210-8i HBA supports SAS/SATA connections through connectors J4 and J5, which are SFF-8087 mini-SAS, internal, right-angle connectors.

Activity LED Header (J3). The LSISAS9210-8i HBA has a 4-pin, right-angle, 0.1-in. pitch header for driving external activity LEDs.

Table 6 LSISAS9210-8i LED Header

Pin	Function
1	3.3 V
2	Port 0
3	Port 1
4	3.3 V

UART Connector (TP1). The UART connector debug port requires a special cable and LSI support to gather detailed IOC status.

Table 7 LSISAS9210-8i UART Pinout

Pin	Function
1	UART0_TX
2	Gnd
3	UART0_RX
4	3.3 V

3.1.2.4 Physical Characteristics

The LSISAS9210-8i HBA is a 6.6-in. × 2.7-in. low-profile board. The component height on the top and bottom of the LSISAS9210-8i HBA is in accordance with the PCIe specifications.

Figure 3 LSISAS9210-8i Board Layout

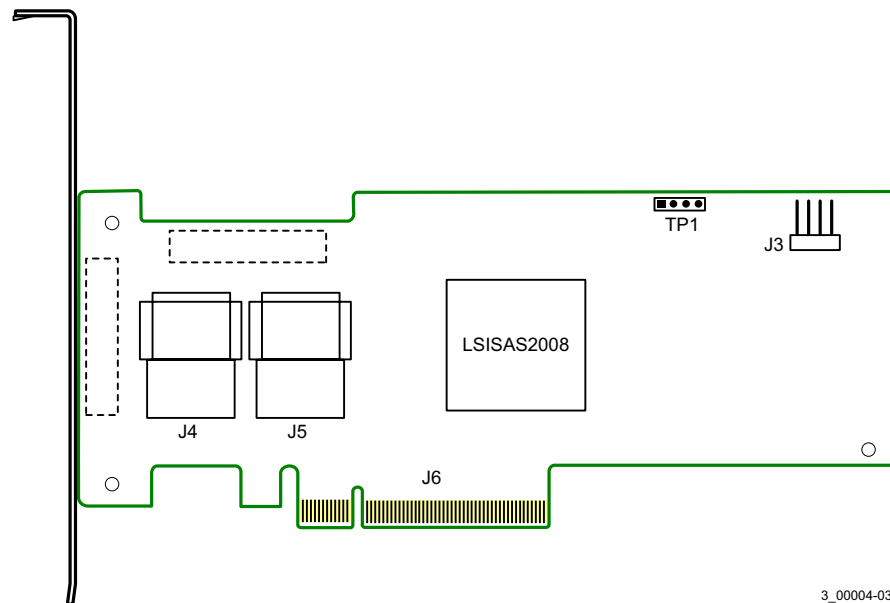

3_00004-03

- J6: PCIe x8-lane board edge connector
- J4, J5: SFF-8087 mini-SAS, internal, right-angle connectors
- J3: 4-pin, right angle, 0.1-in. pitch pin header for driving external activity LEDs
- TP1: UART connection

3.1.3 LSISAS9211-4i HBA Characteristics

3.1.3.1 Memory

The LSISAS9211-4i HBA provides one 4-M × 8-bit Flash ROM for storing the firmware and BIOS. The LSISAS9211-4i HBA can provide up to 32 K × 8-bit NVSRAM for storing nonvolatile RAID information when a system failure occurs.

3.1.3.2 LEDs

The LSISAS9211-4i HBA has a 4-pin header for connection of activity LEDs. The header connects to two LEDs (see [Table 8](#)), which indicate SAS activity on port 0 and port 1.

3.1.3.3 Connectors

This section describes the different connectors on the LSISAS9211-4i HBA. See [Figure 4](#) for connector locations.

PCIe Connector (J1). The LSISAS9211-4i HBA supports a x4 interface. The PCIe host interface connection is through the edge connector, J1, which provides connections on both the top (J1B) and bottom (J1A) of the board. The signal definitions and pin numbers conform to the PCIe specifications.

SAS/SATA Connector (J7). The LSISAS9211-4i HBA supports SAS connections through connector J7, which is an SFF-8087 mini-SAS, internal, right-angle connector.

Activity LED Header (J3). The LSISAS9211-4i HBA has a 4-pin, right-angle, 0.1-in. pitch header for driving external activity LEDs.

Table 8 LSISAS9211-4i LED Header

Pin	Function
1	3.3 V
2	Port 0
3	Port 0
4	3.3 V

UART Connector (J5). The UART connector debug port requires a special cable and LSI support to gather detailed IOC status.

Table 9 LSISAS9211-4i UART Pinout

Pin	Function
1	UART0_TX
2	Gnd
3	UART0_RX
4	3.3 V

3.1.3.4 Physical Characteristics

The LSISAS9211-4i HBA is a 6.6-in. × 2.7-in., low-profile board. The component height on the top and bottom of the LSISAS9211-4i HBA is in accordance with the PCIe specifications.

Figure 4 LSISAS9211-4i Board Layout

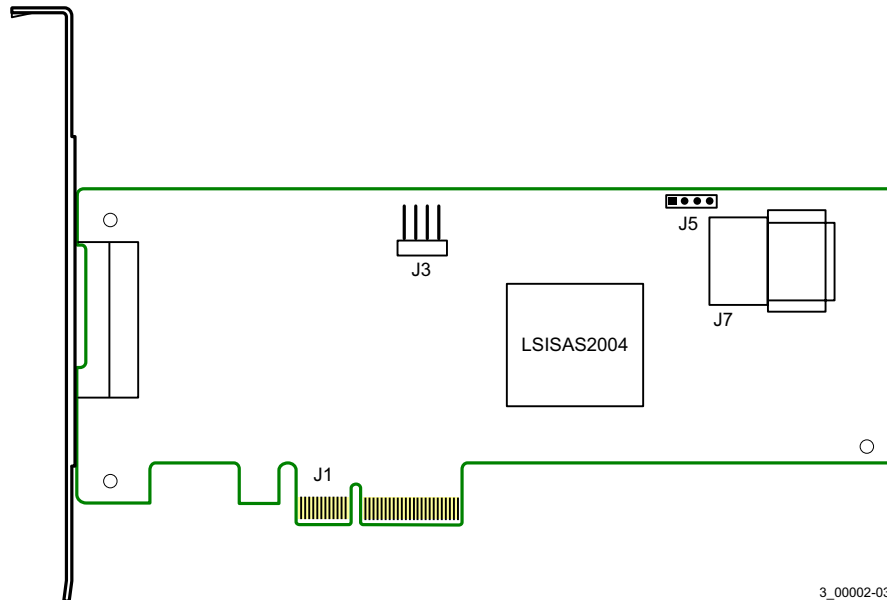

- J1: PCIe x4-lane board edge connector
- J7: SFF-8087 mini-SAS, internal, right-angle connector
- J3: 4-pin, right angle, 0.1-in. pitch, pin header for driving external activity LED
- J5: UART connection

3.1.4 LSISAS9211-8i HBA Characteristics

3.1.4.1 Memory

The LSISAS9211-8i HBA provides one 4-M × 8-bit Flash ROM for storing the firmware and BIOS. The LSISAS9211-8i HBA can provide up to 32 K × 8-bit NVSRAM for storing nonvolatile RAID information when a system failure occurs.

3.1.4.2 LEDs

The LSISAS9211-8i HBA has a 4-pin header for connection of activity LEDs. The 4-pin header connects to two LEDs (see [Table 10](#)), which indicate SAS activity on Port 0 and Port 1.

3.1.4.3 Connectors

This section describes the different connectors on the LSISAS9211-8i HBA. See [Figure 5](#) for connector locations.

PCIe Connector (J1). The LSISAS9211-8i HBA supports a x8 interface. The PCIe host interface connection is through the edge connector, J1, which provides connections on both the top (J1B) and bottom (J1A) of the board. The signal definitions and pin numbers conform to the PCIe specification.

SAS/SATA Connectors (J7 and J8). The LSISAS9211-8i HBA supports SAS connections through connectors J7 and J8, which are SFF-8087 mini-SAS, internal, right-angle connectors.

Activity LED Header (J6). The LSISAS9211-8i HBA has a 4-pin, right-angle, 0.1-in. pitch header for driving external activity LEDs.

Table 10 LSISAS9211-8i LED Header

Pin	Function
1	3.3 V
2	Port 0
3	Port 1
4	3.3 V

UART Connector (J3). The UART connector debug port requires a special cable and LSI support to gather detailed IOC status.

Table 11 LSISAS9211-8i UART Pinout

Pin	Function
1	UART0_TX
2	Gnd
3	UART0_RX
4	3.3 V

3.1.4.4 Physical Characteristics

The LSISAS9211-8i HBA is a 6.6-in. × 2.7-in. low-profile board. The component height on the top and bottom of the LSISAS9211-8i board is in accordance with the PCIe specifications.

Figure 5 LSISAS9211-8i Board Layout

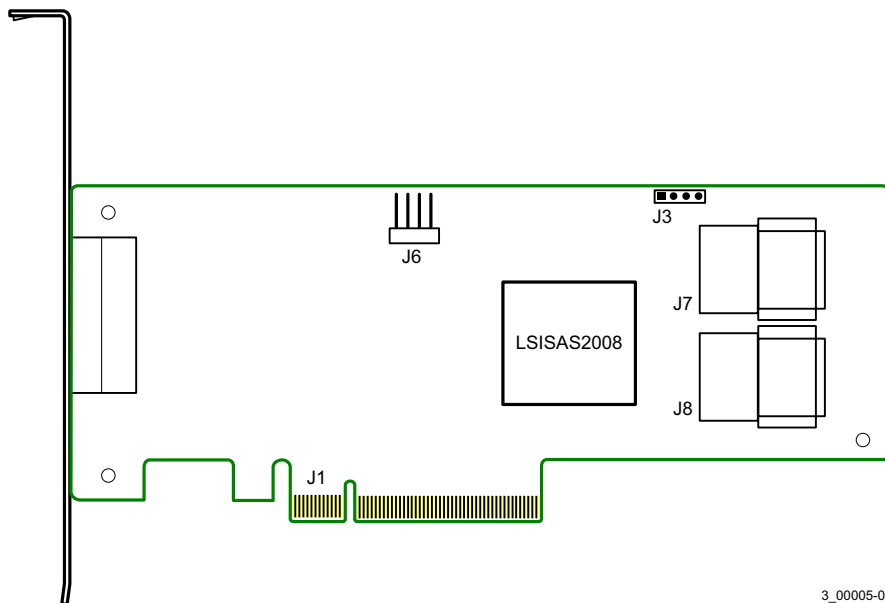

3_00005-03

- J1: PCIe x8-lane board edge connector
- J3: UART connection
- J7, J8: SFF-8087 mini-SAS, internal, right-angle connector
- J6: 4-pin, right angle, 0.1-in. pitch, pin header for driving external LED

3.1.5 LSISAS9212-4i4e HBA Characteristics

3.1.5.1 Memory

The LSISAS9212-4i4e HBA provides one 4-M × 8-bit Flash ROM for storing the firmware and BIOS. The LSISAS9212-4i4e HBA can provide up to 32 K × 8-bit NVSRAM for storing nonvolatile RAID information when a system failure occurs.

3.1.5.2 LEDs

The LSISAS9212-4i4e HBA has a 4-pin header for external connection of activity LEDs. The 4-pin header connects to two LEDs (see [Table 12](#)), which indicate SAS activity on Port 0 and Port 1.

3.1.5.3 Connectors

This section describes the different connectors on the LSISAS9212-4i4e HBA. See [Figure 6](#) for connector locations.

PCIe Connector (J1). The LSISAS9212-4i4e HBA supports a x8 interface. The PCIe host interface connection is through the edge connector, J1, which provides connections on both the top (J1B) and bottom (J1A) of the board. The signal definitions and pin numbers conform to the PCIe specifications.

SAS/SATA Connector (J5, J6, J7, J8, and J12). The LSISAS9212-4i4e HBA supports SAS/SATA connections through connector J12, which is an SFF-8088 mini-SAS, external, right-angle connector, and connectors J5, J6, J7, and J8, which are 7-pin SATA connectors.

Activity LED Header (J11). The LSISAS9212-4i4e HBA has a 4-pin, right-angle, 0.1-in. pitch header for driving external activity LEDs.

Table 12 LSISAS9212-4i4e LED Header

Pin	Function
1	3.3 V
2	Port 0
3	Port 1 ^a
4	3.3 V

a. Port 1 consists of the 7-pin SATA connectors on this HBA.

UART Connector (J4). The UART connector debug port requires a special cable and LSI support to gather detailed IOC status.

Table 13 LSISAS9212-4i4e UART Pinout

Pin	Function
1	UART_TX
2	Gnd
3	UART_RX
4	3.3 V

3.1.5.4 Physical Characteristics

The LSISAS9212-4i4e HBA is a 6.6-in. × 2.7-in. low-profile board. The component height on the top and bottom of the LSISAS9212-4i4e HBA is in accordance with the PCIe specification.

Figure 6 LSISAS9212-4i4e Board Layout

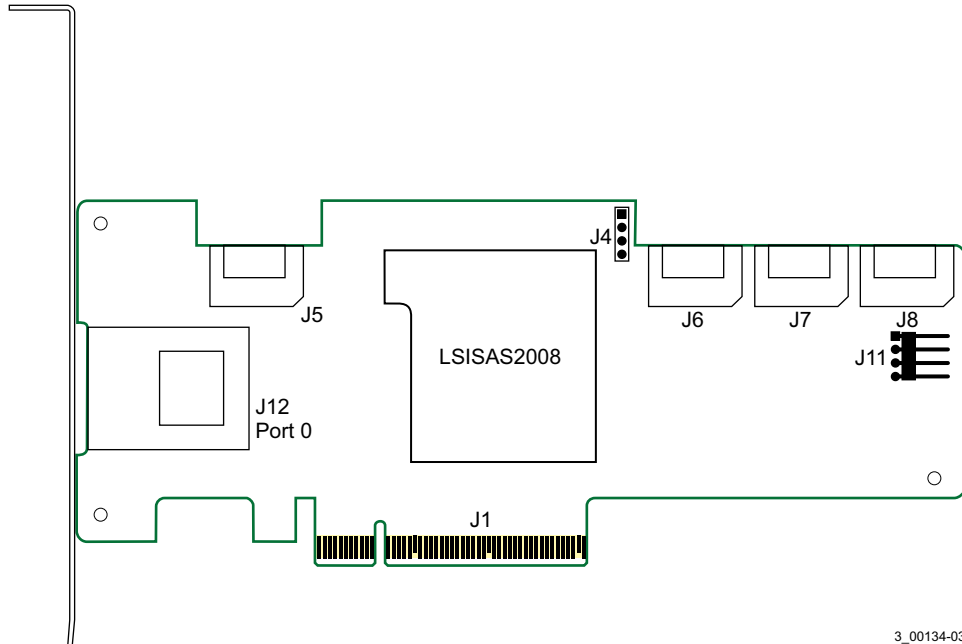

- J1: PCIe x4-lane board edge connector
- J12: SFF-8088 mini-SAS, external, right-angle connector
- J5, J6, J7, J8: x1, internal 7-pin SATA connectors
- J11: 4-pin, right angle, 0.1-in. pitch, pin header for driving external activity LED
- J4: UART connection

3.1.6 LSISAS9200-16e HBA Characteristics

The LSISAS9200-16e HBA supports active copper cable and passive copper cable.

3.1.6.1 Memory

The LSISAS9200-16e HBA provides one 2-M × 16-bit Flash ROM for storing the firmware and BIOS, and provides onboard DDR2 SDRAM.

3.1.6.2 LEDs

The LSISAS9200-16e HBA has two 4-pin headers for external connection of activity LEDs. The LEDs on header J4 correspond to activity on ports 2 and 3, and header J5 corresponds to activity on Port 0 and Port 1.

3.1.6.3 Connectors

This section describes the different connectors on the LSISAS9200-16e HBA. See [Figure 7](#) for connector locations.

PCIe Connector (J10). The LSISAS9200-16e HBA supports a x8 interface. The PCIe host interface connection is through the edge connector, J10, which provides connections on both the top (J10B) and bottom (J10A) of the board. The signal definitions and pin numbers conform to the PCIe specification.

SAS/SATA Connector (J6, J7, J8, J9). The LSI SAS9200-16e HBA supports SAS connections through four external connectors: J6, J7, J8, and J9, which are SFF-8088 mini-SAS, external, right-angle connectors.

Activity LED Headers (J4 and J5). The LSI SAS9200-16e HBA has two 4-pin, right-angle, 0.1-in. pitch headers for driving external activity LEDs.

Table 14 LSI SAS9200-16e LED Header for J4

Pin	Function
1	3.3 V
2	Port 2
3	Port 3
4	3.3 V

Table 15 LSI SAS9200-16e LED Header for J5

Pin	Function
1	3.3 V
2	Port 0
3	Port 1
4	3.3 V

UART Connector (J3). The UART connector debug port requires a special cable and LSI support to gather detailed IOC status.

Table 16 LSI SAS9200-16e UART Pinout

Pin	Function
1	UART_TX
2	Gnd
3	UART_RX
4	3.3 V

3.1.6.4 Physical Characteristics

The LSISAS9200-16e HBA is 8.2-in. × 4.2-in. The component height on the top and bottom of the LSISAS9200-16e HBA is in accordance with the PCIe specifications.

Figure 7 LSISAS9200-16e Board Layout

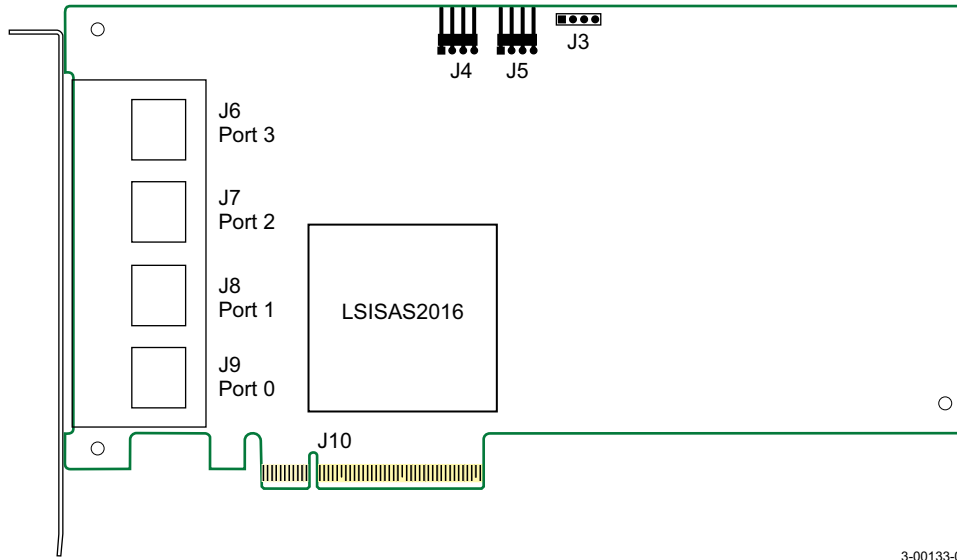

- J10: PCIe x8-lane board edge connector
- J6, J7, J8, J9: SFF-8088 mini-SAS, external, right-angle connectors
- J4 and J5: 4-pin, right angle, 0.1-in. pitch pin header for driving external activity LED
- J3: UART connection

3.1.7 LSISAS9201-16e HBA Characteristics

The LSISAS9201-16e supports active copper cable and passive copper cable.

3.1.7.1 Memory

The LSISAS9201-16e HBA provides one 2-M × 16-bit Flash ROM for storing the firmware and BIOS, and provides onboard DDR2 SDRAM.

3.1.7.2 LEDs

The LSISAS9201-16e HBA has two 4-pin headers for external connection of activity LEDs. The LEDs on header J3 correspond to activity on ports C and D, and header J4 corresponds to activity on ports A and B.

3.1.7.3 Connectors

This section describes the different connectors on the LSISAS9201-16e HBA. See [Figure 8](#) for connector locations.

PCIe Connector (EC1). The LSISAS9201-16e HBA supports a x8 interface. The PCIe host interface connection is through the edge connector, EC1, which provides connections on both the top (EC1B) and bottom (EC1A) of the board. The signal definitions and pin numbers conform to the PCIe specifications.

SAS/SATA Connector (J6, J7, J8, J9). The LSISAS9201-16e HBA supports SAS connections through four external connectors: J6, J7, J8, and J9, which are SFF-8088 mini-SAS, external, right-angle connectors.

Activity LED Headers (J3 and J4). The LSISAS9201-16e HBA has two 4-pin, right-angle, 0.1-in. pitch headers for driving external activity LEDs.

Table 17 LSISAS9201-16e LED Header for J3

Pin	Function
1	3.3 V
2	Port C
3	Port D
4	3.3 V

Table 18 LSISAS9201-16e LED Header for J4

Pin	Function
1	3.3 V
2	Port A
3	Port B
4	3.3 V

UART Connector (J5). The UART connector debug port requires a special cable and LSI support to gather detailed IOC status.

Table 19 LSISAS9201-16e UART Pinout

Pin	Function
1	UART_TX
2	Gnd
3	UART_RX
4	3.3 V

3.1.7.4 Physical Characteristics

The LSISAS9201-16e HBA is 6.6-in. × 4.2-in. The component height on the top and bottom of the LSISAS9201-16e HBA is in accordance with the PCIe specification.

Figure 8 LSISAS9201-16e Board Layout

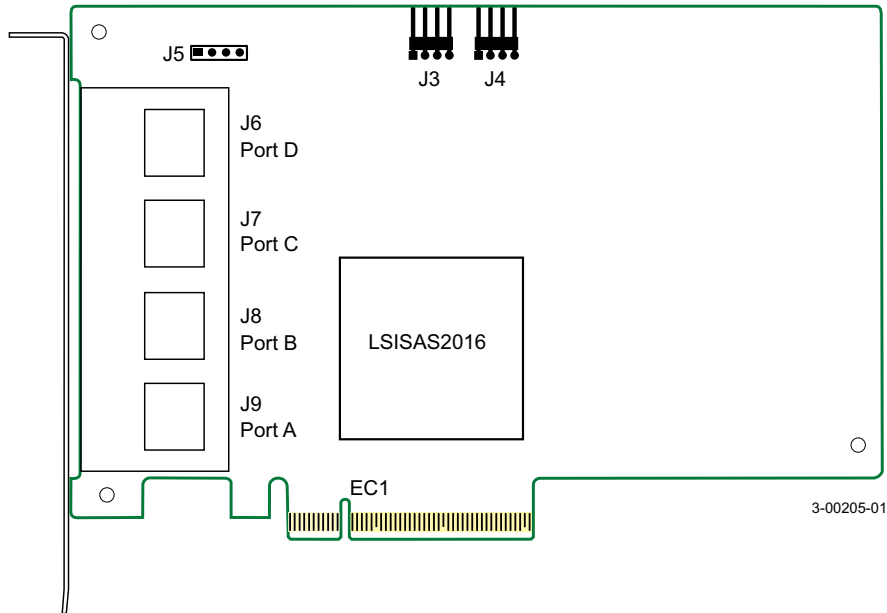

- EC1: PCIe x8-lane board edge connector
- J6, J7, J8, J9: SFF-8088 mini-SAS, external, right-angle connectors
- J3 and J4: 4-pin, right angle, 0.1-in. pitch, pin header for driving external activity LED
- J5: UART connection

3.1.8 LSISAS9201-16i HBA Characteristics

3.1.8.1 Memory

The LSISAS9201-16i HBA provides one 2-M × 16-bit Flash ROM for storing the firmware and BIOS, and provides onboard DDR2 SDRAM.

3.1.8.2 LEDs

The LSISAS9201-16i HBA has two 4-pin headers for connection of activity LEDs. The LEDs on header J4 correspond to activity on ports C and D, and header J5 corresponds to activity on Port A and Port B.

3.1.8.3 Connectors

This section describes the different connectors on the LSISAS9201-16i HBA. See [Figure 9](#) for connector locations.

PCIe Connector (EC1). The LSISAS9201-16i HBA supports a x8 interface. The PCIe host interface connection is through the edge connector, EC1, which provides connections on both the top (EC1B) and bottom (EC1A) of the board. The signal definitions and pin numbers conform to the PCIe specifications.

SAS/SATA Connector (J6, J7, J8, J9). The LSISAS9201-16i HBA supports SAS connections through four external connectors: J6, J7, J8, and J9, which are SFF-8087 mini-SAS, internal, right-angle connectors.

Activity LED Headers (J4 and J5). The LSISAS9201-16i HBA has two 4-pin, right-angle, 0.1-in. pitch headers for driving external activity LEDs.

Table 20 LSISAS9201-16i LED Header for J4

Pin	Function
1	3.3 V
2	Port C
3	Port D
4	3.3 V

Table 21 LSISAS9201-16i LED Header for J5

Pin	Function
1	3.3 V
2	Port A
3	Port B
4	3.3 V

UART Connector (J1). The UART connector debug port requires a special cable and LSI support to gather detailed IOC status.

Table 22 LSISAS9201-16i UART Pinout

Pin	Function
1	UART_TX
2	Gnd
3	UART_RX
4	3.3 V

3.1.8.4 Physical Characteristics

The LSISAS9201-16i HBA is 6.6-in. × 4.2-in. The component height on the top and bottom of the LSISAS9201-16i board is in accordance with the PCIe specifications.

Figure 9 LSISAS9201-16i Board Layout

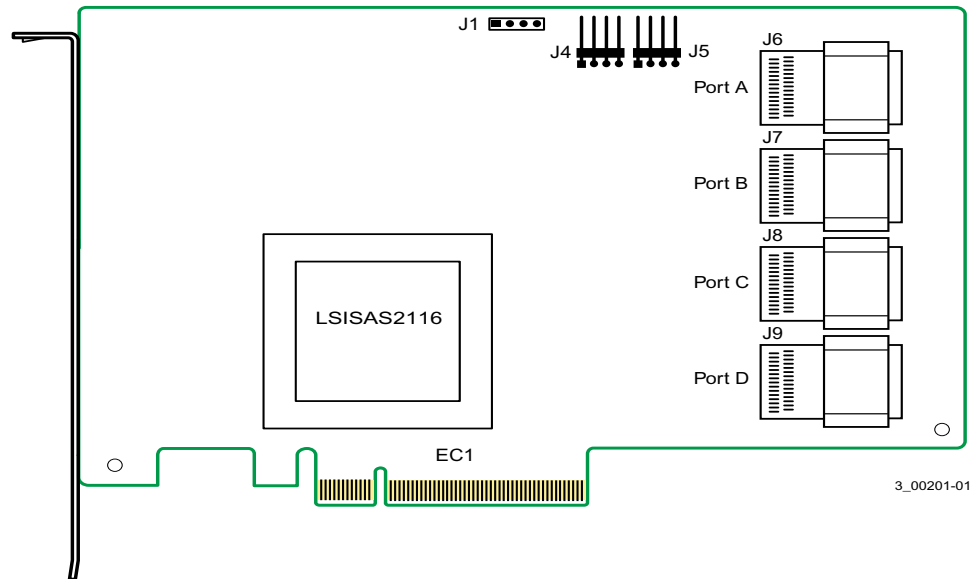

- EC1: PCIe x8-lane board edge connector
- J6, J7, J8, J9: SFF-8087 mini-SAS, internal, right-angle connectors
- J4 and J5: 4-pin, right angle, 0.1-in. pitch pin header for driving external activity LED
- J1: UART connection

3.1.9 LSISAS9202-16e HBA Characteristics

The LSISAS9202-16e HBA supports active copper cable and passive copper cable.

3.1.9.1 Memory

The LSISAS9202-16e HBA provides two 4-M × 8-bit Flash ROMs for storing the firmware and BIOS.

3.1.9.2 LEDs

The two LSISAS9202-16e HBA heartbeat LEDs, CR1 and CR2, blink green to indicate that the HBA is capable of general activity.

3.1.9.3 Connectors

This section describes the different connectors on the LSISAS9202-16e HBA. See [Figure 10](#) for connector locations.

PCIe Connector (EC1). The LSISAS9202-16e HBA supports a x16 interface. The PCIe host interface connection is through the edge connector, EC1, which provides connections on both the top (EC1B) and bottom (EC1A) of the board. The signal definitions and pin numbers conform to the PCIe specification.

SAS/SATA Connector (J3). The LSISAS9202-16e HBA supports SAS connections through four external connectors: J3, ports A, B, C, and D, which are SFF-8644 mini-SAS HD, external, right-angle connectors.

UART Connector (J2, J5). The UART connector debug port requires a special cable and LSI support to gather detailed IOC status. Both of the UART headers use the following pinout.

Table 23 LSISAS9202-16e UART Pinout

Pin	Function
1	UART_TX
2	Gnd
3	UART_RX
4	3.3 V

3.1.9.4 Physical Characteristics

The LSISAS9202-16e HBA is 6.6-in. × 2.7-in. The component height on the top and bottom of the LSISAS9202-16e HBA is in accordance with the PCIe specification.

Figure 10 LSISAS9202-16e Board Layout

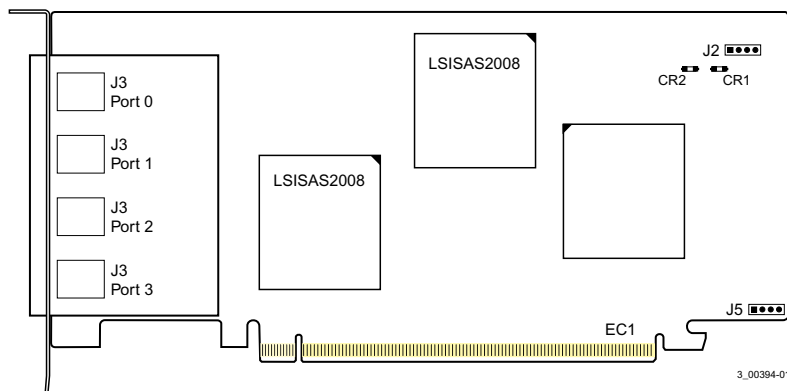

- EC1: PCIe x16-lane board edge connector
- J3, Ports 0, 1, 2, 3: SFF-8644 mini-SAS HD external connectors
- CR1, CR2: Heartbeat LEDs
- J2, J5: UART connections

3.1.10 LSISAS9205-8e HBA Characteristics

3.1.10.1 Memory

The LSISAS9205-8e HBA provides one 4-M × 16-bit Flash ROM for storing the firmware and BIOS.

3.1.10.2 LED

The LSISAS9205-8e HBA heartbeat LED, CR1, blinks green to indicate that the HBA is capable of general activity.

3.1.10.3 Connectors

This section describes the different connectors on the LSISAS9205-8e HBA. See [Figure 11](#) for connector locations.

PCIe Connector (EC1). The LSISAS9205-8e HBA supports a x8 interface. The PCIe host interface connection is through the edge connector (EC1) which provides connections on both the top (EC1B) and bottom (EC1A) of the board. The signal definitions and pin numbers conform to the PCIe specification.

SAS/SATA Connectors (J5 and J6). The LSI SAS9205-8e HBA supports SAS/SATA connections through connectors J5 and J6, which are SFF-8088 mini-SAS, external, right-angle connectors.

UART Connector (J4). The UART connector debug port requires a special cable and LSI support to gather detailed IOC status.

Table 24 LSI SAS9205-8e UART Pinout

Pin	Function
1	UART_TX
2	Gnd
3	UART_RX
4	+1.8 V

3.1.10.4 Physical Characteristics

The LSI SAS9205-8e HBA is a 6.6-in. × 2.7-in., low-profile board. The component height on the top and bottom of the LSI SAS9205-8e HBA is in accordance with the PCIe specification. The following figure shows the board layout.

Figure 11 LSI SAS9205-8e Board Layout

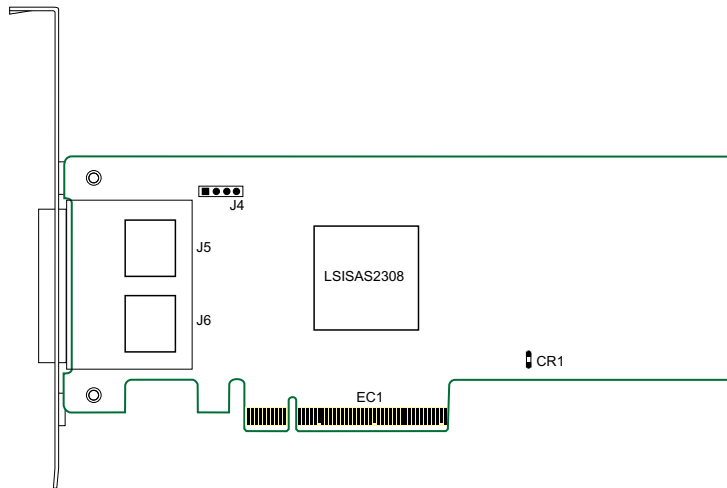

- EC1: PCIe x8-lane board edge connector
- J5, J6: SFF-8088 mini-SAS, external, right-angle connectors
- CR1: Heartbeat LED
- J4: UART connection

3.1.11 LSISAS9207-8e HBA Characteristics

The LSISAS9207-8e HBA supports active copper cable and passive copper cable.

3.1.11.1 Memory

The LSISAS9207-8e HBA provides one 4 M × 16-bit Flash ROM for storing the firmware and BIOS.

3.1.11.2 LED

The LSISAS9207-8e HBA heartbeat LED, CR1, blinks green to indicate that the HBA is capable of general activity.

3.1.11.3 Connectors

This section describes the different connectors on the LSISAS9207-8e HBA. See [Figure 12](#) for connector locations.

PCIe Connector (EC1). The LSISAS9207-8e HBA supports a x8 interface. The PCIe host interface connection is through the edge connector (EC1) which provides connections on both the top (EC1B) and bottom (EC1A) of the board. The signal definitions and pin numbers conform to the PCIe specification.

SAS/SATA Connectors (J10 and J11). The LSISAS9207-8e HBA supports SAS/SATA connections through connectors J10 and J11, which are SFF-8088 mini-SAS, external, right-angle connectors.

UART Connector (J4). The UART connector debug port requires a special cable and LSI support to gather detailed IOC status.

Table 25 LSISAS9207-8e UART Pinout

Pin	Function
1	UART0_TX
2	Gnd
3	UART0_RX
4	+1.8 V

3.1.11.4 Physical Characteristics

The LSISAS9207-8e HBA is a 6.6-in. × 2.7-in., low-profile board. The component height on the top and bottom of the LSISAS9207-8e HBA is in accordance with the PCIe specification. The following figure shows the board connectors.

Figure 12 LSISAS9207-8e Board Layout

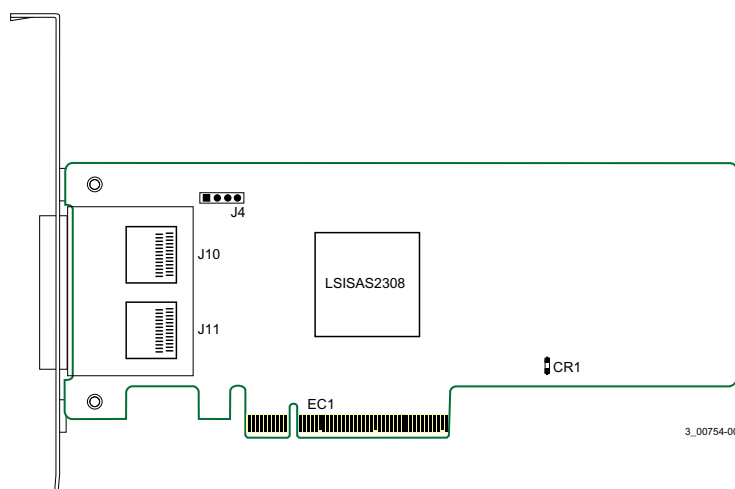

- EC1: PCIe x8-lane board edge connector
- CR1: Heartbeat LED
- J4: UART connection
- J10, J11: SFF-8088 mini-SAS, external, right-angle connectors

3.1.12 LSISAS9207-8i HBA Characteristics

3.1.12.1 Memory

The LSISAS9207-8i HBA provides one 4 M × 16-bit Flash ROM for storing the firmware and BIOS.

3.1.12.2 LED

The LSISAS9207-8i HBA heartbeat LED, CR1, blinks green to indicate that the HBA is capable of general activity.

3.1.12.3 Connectors

This section describes the different connectors on the LSISAS9207-8i HBA. See [Figure 15](#) for connector locations.

PCIe Connector (EC1). The LSISAS9207-8i HBA supports a x8 interface. The PCIe host interface connection is through the edge connector (EC1) which provides connections on both the top (EC1B) and bottom (EC1A) of the board. The signal definitions and pin numbers conform to the PCIe specification.

SAS/SATA Connectors (J5 and J6). The LSISAS9207-8i HBA supports SAS/SATA connections through connectors J5 and J6, which are SFF-8087 mini-SAS, internal connectors. The HBA supports SAS sideband signal assignments.

UART Connector (J3). The UART connector debug port requires a special cable and LSI support to gather detailed IOC status.

Table 26 LSISAS9207-8i UART Pinout

Pin	Function
1	UART0_TX
2	Gnd
3	UART0_RX
4	+1.8 V

3.1.12.4 Physical Characteristics

The LSISAS9207-8i HBA is a 6.6-in. × 2.7-in., low-profile board. The component height on the top and bottom of the LSISAS9207-8i HBA is in accordance with the PCIe specification. The following figure shows the board layout.

Figure 13 LSISAS9207-8i Board Layout

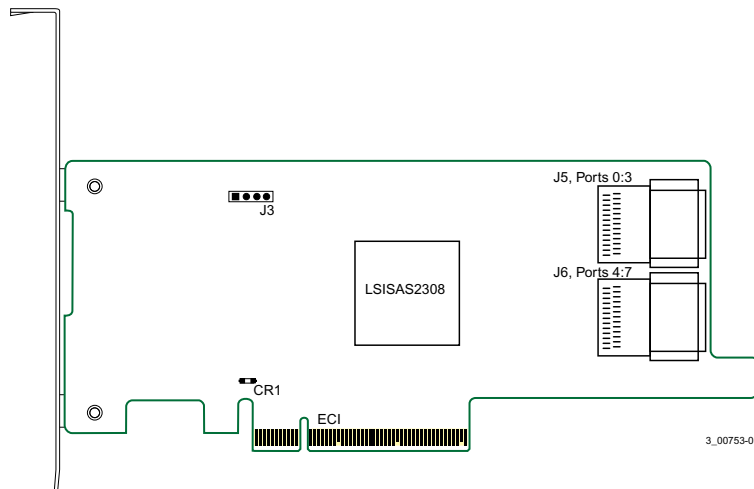

- EC1: PCIe x8-lane board edge connector
- J5, J6: SFF-8087 mini-SAS, internal connectors
- CR1: Heartbeat LED
- J3: UART connection

3.1.13 LSISAS9207-4i4e HBA Characteristics

3.1.13.1 Memory

The LSISAS9207-4i4e HBA provides one 4-M × 16-bit Flash ROM for storing the firmware and BIOS.

3.1.13.2 LED

The LSISAS9207-4i4e HBA heartbeat LED, CR1, blinks green to indicate that the HBA is capable of general activity.

3.1.13.3 Connectors

This section describes the different connectors on the LSISAS9207-4i4e HBA. See [Figure 14](#) for connector locations.

PCIe Connector (EC1). The LSISAS9207-4i4e HBA supports a x8 interface. The PCIe host interface connection is through the edge connector (EC1) which provides connections on both the top (EC1B) and bottom (EC1A) of the board. The signal definitions and pin numbers conform to the PCIe specification.

SAS Connector (J6 and J7). The LSISAS9207-4i4e HBA supports SAS connections through connector J6, which is an SFF-8088 mini-SAS, external, right-angle connector, and connector J7 which is an SFF-8087 internal mini-SAS connector. The HBA supports SAS sideband signal assignments.

UART Connector (J5). The UART connector debug port requires a special cable and LSI support to gather detailed IOC status.

Table 27 LSISAS9207-4i4e UART Pinout

Pin	Function
1	UART0_TX
2	Gnd
3	UART0_RX
4	+1.8 V

3.1.13.4 Physical Characteristics

The LSISAS9207-4i4e HBA is a 6.6-in × 2.7-in., low-profile board. The component height on the top and bottom of the LSISAS9207-4i4e HBA is in accordance with the PCIe specification. The following figure shows the board layout.

Figure 14 LSISAS9207-4i4e Board Layout

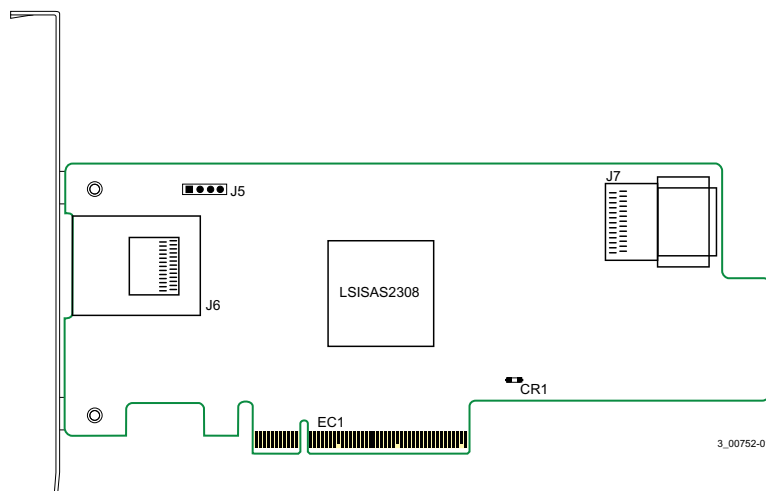

- EC1: PCIe x8-lane board edge connector
- J6: SFF-8088 mini-SAS, external, right-angle connectors
- J7: SFF-8087 mini-SAS, internal
- CR1: Heartbeat LED
- J5: UART connection

3.1.14 LSISAS9217-8i HBA Characteristics

3.1.14.1 Memory

The LSISAS9217-8i HBA provides one 4 M × 16-bit Flash ROM for storing the firmware and BIOS. The LSISAS9217-8i HBA can provide up to 32 K × 8-bit NVSRAM for storing the nonvolatile RAID information when a system failure occurs.

3.1.14.2 LED

The LSISAS9217-8i HBA heartbeat LED, CR1, blinks green to indicate that the HBA is capable of general activity.

3.1.14.3 Connectors

This section describes the different connectors on the LSISAS9217-8i HBA. See [Figure 15](#) for connector locations.

PCIe Connector (EC1). The LSISAS9217-8i HBA supports a x8 interface. The PCIe host interface connection is through the edge connector (EC1) which provides connections on both the top (EC1B) and bottom (EC1A) of the board. The signal definitions and pin numbers conform to the PCIe specification.

SAS/SATA Connectors (J5 and J6). The LSISAS9217-8i HBA supports SAS/SATA connections through connectors J5 and J6, which are SFF-8087 mini-SAS, internal connectors. The HBA supports SAS sideband signal assignments.

UART Connector (J3). The UART connector debug port requires a special cable and LSI support to gather detailed IOC status.

Table 28 LSISAS9217-8i UART Pinout

Pin	Function
1	UART0_TX
2	Gnd
3	UART0_RX
4	+1.8 V

3.1.14.4 Physical Characteristics

The LSISAS9217-8i HBA is a 6.6-in. × 2.7-in., low-profile board. The component height on the top and bottom of the LSISAS9217-8i HBA is in accordance with the PCIe specification. The following figure shows the board layout.

Figure 15 LSISAS9217-8i Board Layout

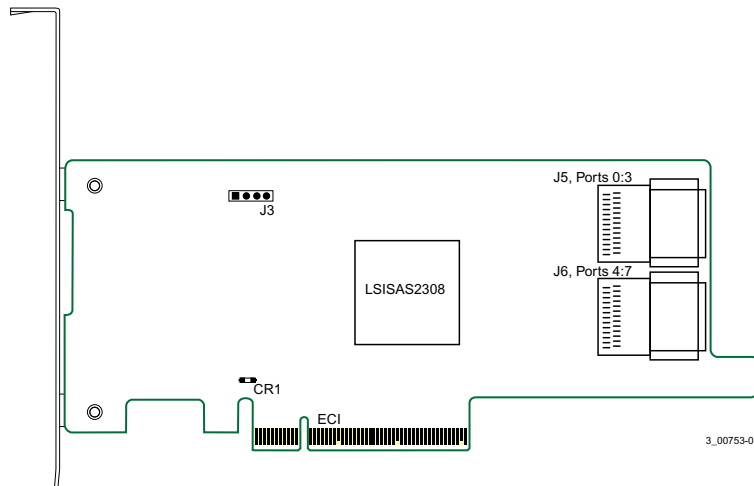

- EC1: PCIe x8-lane board edge connector
- J5, J6: SFF-8087 mini-SAS, internal connectors
- CR1: Heartbeat LED
- J3: UART connection

3.1.15 LSIAS9217-4i4e HBA Characteristics

3.1.15.1 Memory

The LSIAS9217-4i4e HBA provides one 4-M × 16-bit Flash ROM for storing the firmware and BIOS. The LSIAS9217-4i4e HBA can provide up to 32 K × 8-bit NVSRAM for storing the nonvolatile RAID information when a system failure occurs.

3.1.15.2 LED

The LSIAS9217-4i4e HBA heartbeat LED, CR1, blinks green to indicate that the HBA is capable of general activity.

3.1.15.3 Connectors

This section describes the different connectors on the LSIAS9217-4i4e HBA. See [Figure 14](#) for connector locations.

PCIe Connector (EC1). The LSIAS9217-4i4e HBA supports a x8 interface. The PCIe host interface connection is through the edge connector (EC1) which provides connections on both the top (EC1B) and bottom (EC1A) of the board. The signal definitions and pin numbers conform to the PCIe specification.

SAS Connector (J6 and J7). The LSIAS9217-4i4e HBA supports SAS connections through connector J6, which is an SFF-8088 mini-SAS, external, right-angle connector, and connector J7 which is an SFF-8087 internal mini-SAS connector. The HBA supports SAS sideband signal assignments.

UART Connector (J5). The UART connector debug port requires a special cable and LSI support to gather detailed IOC status.

Table 29 LSIAS9217-4i4e UART Pinout

Pin	Function
1	UART0_TX
2	Gnd
3	UART0_RX
4	+1.8 V

3.1.15.4 Physical Characteristics

The LSI SAS9217-4i4e HBA is a 6.6-in × 2.7-in., low-profile board. The component height on the top and bottom of the LSI SAS9217-4i4e HBA is in accordance with the PCIe specification. The following figure shows the board layout.

Figure 16 LSI SAS9217-4i4e Board Layout

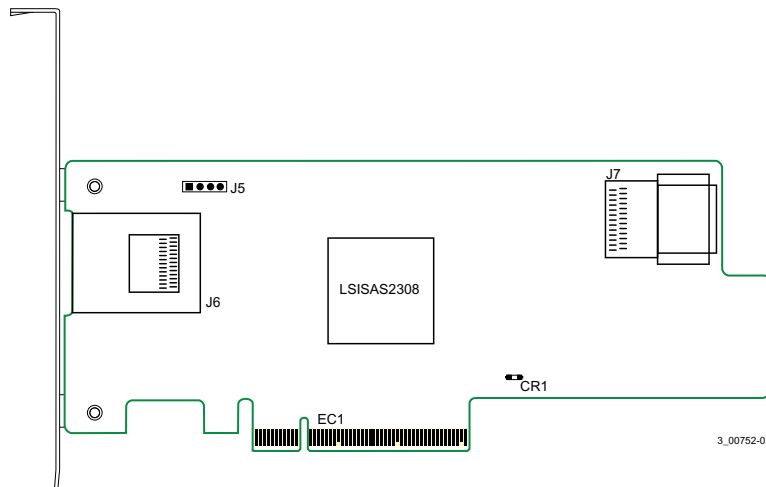

- EC1: PCIe x8-lane board edge connector
- J6: SFF-8088 mini-SAS, external, right-angle connectors
- J7: SFF-8087 mini-SAS, internal
- CR1: Heartbeat LED
- J5: UART connection

3.1.16 LSI SAS9206-16e HBA Characteristics

The LSI SAS9206-16e HBA supports active and passive copper cables, and optical cable.

3.1.16.1 Memory

The LSI SAS9206-16e HBA provides two 4-M × 16-bit Flash ROMs for storing the firmware and BIOS.

3.1.16.2 LED

The two LSI SAS9206-16e HBA heartbeat LEDs, CR4B1 and CR5B1, blink green to indicate that the HBA is capable of general activity.

3.1.16.3 Connectors

This section describes the different connectors on the LSI SAS9206-16e HBA. See [Figure 17](#) for connector locations.

PCIe Connector (J2B1). The LSI SAS9206-16e HBA supports a x8 interface. The PCIe host interface connection is through the edge connector (J2B1) which provides connections on both the top and bottom of the board. The signal definitions and pin numbers conform to the PCIe specification.

SAS Connectors (J1A2). The LSI SAS9206-16e HBA supports SAS/SATA connections through J1A2 Port 0, Port 1, Port 2, and Port 3, which are SFF-8644 mini-SAS HD, external, right-angle connectors.

UART Connectors (J2A1 and J2A2). The UART connector debug port requires a special cable and LSI support to gather detailed IOC status.

Table 30 LSI SAS9206-16e UART Pinout, J2A1 and J2A2

Pin	Function
1	UART0_TX
2	Gnd
3	UART0_RX
4	+1.8 V

3.1.16.4 Physical Characteristics

The LSI SAS9206-16e HBA is a 6.6-in × 2.7-in., low-profile board. The component height on the top and bottom of the LSI SAS9206-16e HBA is in accordance with the PCIe specification. The following figure shows the board layout.

Figure 17 LSI SAS9206-16e Board Layout

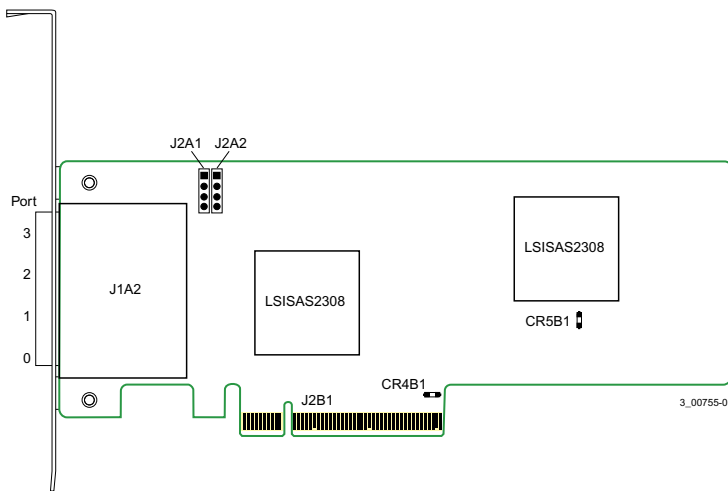

- J2B1: PCIe x8-lane board edge connector
- J1A2: SFF-8644 mini-SAS HD, external, right-angle connectors
- CR4B1 and CR5B1: Heartbeat LEDs
- J2A1 and J2A2: UART connections

3.2 Environmental Specifications

3.2.1 Power Requirements

The following table lists the maximum power requirements for the LSI 6Gb/s HBAs under normal operation.

Table 31 Maximum Power Requirements

HBA Model	PCIe 12.0 V	Nominal Power	Worst-Case Power	Operating Range
LSISAS9200-8e	1.10 A	7.8 W	13.20 W	0 °C to 55 °C
LSISAS9210-8i	1.21 A	7.5 W	14.63 W	0 °C to 55 °C
LSISAS9211-4i	0.96 A	6.3 W	11.51 W	0 °C to 55 °C
LSISAS9211-8i	1.21 A	6.4 W	14.63 W	0 °C to 55 °C
LSISAS9212-4i4e	1.21 A	8.3 W	14.63 W	0 °C to 55 °C
LSISAS9200-16e ^a	1.67 A	16.2 W	20.00 W	0 °C to 55 °C
LSISAS9200-16e (active)	2.00 A	16.2 W	24.00 W	0 °C to 55 °C
LSISAS9201-16e ^a	1.74 A	16.7 W	20.94 W	0 °C to 55 °C
LSISAS9201-16e (active)	2.08 A	16.7 W	24.94 W	0 °C to 55 °C
LSISAS9201-16i	2.08 A	15.6 W	24.94 W	0 °C to 55 °C
LSISAS9202-16e ^a	2.26 A	16.2 W	27.09 W	0 °C to 55 °C
LSISAS9202-16e (active)	2.26 A	20.2 W	31.09 W	0 °C to 55 °C
LSISAS9205-8e	1.26 A	8.2 W	15.15 W	0 °C to 55 °C
LSISAS9207-8e ^a	1.30 A	9.8 W	16.00 W	0 °C to 55 °C
LSISAS9207-8e (active)	1.60 A	9.8 W	19.60 W	0 °C to 55 °C
LSISAS9207-8i	1.30 A	9.8 W	16.00 W	0 °C to 55 °C
LSISAS9207-4i4e	1.30 A	9.8 W	16.00 W	0 °C to 55 °C
LSISAS9217-8i	1.30 A	9.8 W	16.00 W	0 °C to 55 °C
LSISAS9217-4i4e	1.30 A	9.8 W	16.00 W	0 °C to 55 °C
LSISAS9206-16e ^a	1.60 A	19.2 W	24.60 W	0 °C to 55 °C
LSISAS9206-16e (active)	1.60 A	21.6 W	27.20 W	0 °C to 55 °C

a. The power-requirements data for this HBA increases if active cables are supported.

3.2.2 Thermal and Atmospheric Limits

The atmospheric limits for the LSI 6Gb/s HBAs are as follows:

- Temperature range: 0 °C to 55 °C (32 °F to 131 °F) (dry bulb)
- Relative humidity range: 5 percent to 90 percent noncondensing
- Maximum dew point temperature: 32 °C (89.6 °F)
- Minimum airflow: 200 linear feet per minute

The following limits define the storage and transit environment for the LSI 6Gb/s HBAs:

- Temperature range: -45 °C to +105 °C (-49 °F to +221 °F) (dry bulb)
- Relative humidity range: 5 percent to 90 percent noncondensing

3.3 LSI PCIe-to-SAS HBA Certifications and Safety Characteristics

All LSI 6Gb/s HBAs meet or exceed the requirements of UL flammability rating 94V-0. Each bare board is marked with the supplier's name or trademark, type, and UL flammability rating. Because these boards are installed in a PCIe bus slot, all voltages are less than the SELV 42.4-V limit.

The design and implementation of the LSI 6Gb/s HBAs minimizes electromagnetic emissions, susceptibility to radio frequency energy, and the effects of electrostatic discharge.

The LSI 6Gb/s HBAs meet the following integrated electromagnetic interference (EMI) compliance labels:

- CE mark
- CISPR Class B
- C-Tick mark
- Canadian Compliance Statement
- FCC Class B, marked with the FCC Self-Certification logo
- Japan VCCI
- Korean KCC
- Taiwan BSMI

The LSI 6Gb/s HBAs meet the following environmental directives:

- RoHS
- WEEE

Appendix A: HBA Feature Matrix

The following table lists the features for all LSI 6Gb/s HBAs. All LSI 6Gb/s HBAs operate at SAS speeds up to 6Gb/s.

HBA	Controller	FW	Form Factor ^a	Cable Support ^b	External LED 4-Pin Headers	SATA/SAS Device Support	PCIe		Connectors		
							Gen	Lanes	Int	Ext	Type
LSISAS9200-8e	LSISAS2008	IT	LP	P	1	512	2.0	x8	—	2	Mini-SAS SFF-8088
LSISAS9210-8i	LSISAS2008	IR	LP	P	1	256	2.0	x8	2 top	—	Mini-SAS SFF-8087
LSISAS9211-4i	LSISAS2008	IR	LP	P	1	256	2.0	x4	1 side	—	Mini-SAS SFF-8087
LSISAS9211-8i	LSISAS2008	IR	LP	P	1	256	2.0	x8	2 side	—	Mini-SAS SFF-8087
LSISAS9212-4i4e	LSISAS2008	IR	LP	P	1	256	2.0	x8	4 (x1)	1	SATA/Mini-SAS SFF-8088
LSISAS9200-16e	LSISAS2116	IT	FH x 8.2"	P, A	2	512	2.0	x8	—	4	Mini-SAS SFF-8088
LSISAS9201-16e	LSISAS2116	IT	FH x 6.6"	P, A	2	512	2.0	x8	—	4	Mini-SAS SFF-8088
LSISAS9201-16i	LSISAS2116	IT	FH x 6.6"	P	2	512	2.0	x8	4 side	—	Mini-SAS SFF-8087
LSISAS9202-16e	LSISAS2008	IT	LP	P, A	—	1024 per IOC	2.0	x16	—	4	Mini-SAS HD SFF-8644
LSISAS9205-8e	LSISAS2308	IT	LP	P	—	1024	2.0	x8	—	2	Mini-SAS SFF-8088
LSISAS9207-8e	LSISAS2308	IT	LP	P, A	—	1024	3.0	x8	—	2	Mini-SAS SFF-8088
LSISAS9207-8i	LSISAS2308	IT	LP	P	—	1024	3.0	x8	2 side	—	Mini-SAS SFF-8087
LSISAS9207-4i4e	LSISAS2308	IT	LP	P	—	1024	3.0	x8	1 side	1	Mini-SAS SFF-8087 and SFF-8088
LSISAS9217-8i	LSISAS2308	IR	LP	P	—	256	3.0	x8	2 side	—	Mini-SAS SFF-8087
LSISAS9217-4i4e	LSISAS2308	IR	LP	P	—	256	3.0	x8	1 side	1	Mini-SAS SFF-8087 and SFF-8088
LSISAS9206-16e	LSISAS2308	IT	LP	P, A, O	—	1024 per IOC	3.0	x8	—	4	Mini-SAS HD SFF-8644

a. LP indicates low-profile. FH indicates full-height.

b. P indicates passive. A indicates active. O indicates optical.

